

Rigging & Assembly Instructions

AT ATLAS

INDUCED DRAFT
MODULAR
COUNTERFLOW
COOLING TOWERS



Mr. GoodTower®





Table of Contents

Introduction	1
Shipping	1
Nomenclature	1
Structural Steel Support	2
Rigging Basin Sections	3
Joining Bottom Sections	3
Outlet Piping	5
Application of Sealer Tape to Basin Sections	6
Rigging Casing Sections	6
Assembly of the Casing Sections to the Basin Sections	7
Assembly of Bottom Inlet Piping	8
Application of Sealer Tape to Casing Sections	9
Rigging Fan Sections	10
Assembly of the Fan Sections to the Casing Sections	11
Rigging Fan Sections on Multi-cell Units	12
Fan Sealing	13
Extended Lifts	13
Floating Shaft Installation & Alignment	14
Fan Assembly Instructions	15
Rigging Drive Assembly	16
Standard Fan Cylinder Assembly	17
Super Low Sound Fan Cylinder Assembly	19
Fan Cylinder Rigging	22
Motor Segment Seal Sheet Installation	23
Fan Cylinder Sealing	25
Super Low Sound Fan Cylinder Diagonal Supports	26
Installing Watertight Partitions & FM Partition Panels	26
External Platform and Vertical Ladder Installation	27
Appendix A	30
Notes	31

The AT ATLAS INDUCED DRAFT MODULAR COUNTERFLOW COOLING TOWERS should be rigged and assembled using the instructions and recommendations outlined in this bulletin.

All personnel should review these procedures, as well as the latest industry-approved installation practices, prior to rigging and assembly. The information in this bulletin is for informational purposes only. These instructions do not purport to cover all variations and possible contingencies in connection with installation. Additionally, the procedures described herein are subject to change without prior notice, due to EVAPCO, Inc.'s ongoing research and development.

EVAPCO, Inc. makes no representations or warranties with respect to these instructions or the products described herein. Nor shall EVAPCO, Inc. be responsible for any loss or damage (direct, indirect, consequential, or other) during installation or handling of equipment after shipment.

For a full description of EVAPCO's liability policy, please visit www.evapco.com to access our Terms and Conditions.

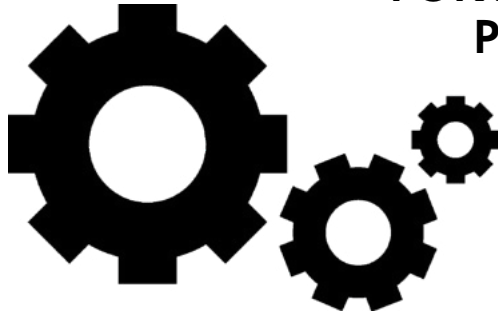

**FOR EVAPCO AUTHORIZED
PARTS AND SERVICE,
CONTACT YOUR
LOCAL EVAPCO
REPRESENTATIVE
OR THE LOCAL
SERVICE CENTER**



Mr. GoodTower®



EVAPCO, Inc. — World Headquarters & Research / Development Center

P.O. Box 1300 • Westminster, MD 21158 USA
410.756.2600 • marketing@evapco.com • evapco.com

North America

EVAPCO, Inc.
World Headquarters
Westminster, MD USA
410.756.2600
marketing@evapco.com

EVAPCO East
Taneytown, MD USA

EVAPCO East
Key Building
Taneytown, MD USA

EVAPCO Midwest
Greenup, IL USA
217.923.3431
evapcomw@evapcomw.com

Evapcold Manufacturing
Greenup, IL USA

EVAPCO Newton
Newton, IL USA
618.783.3433
evapcomw@evapcomw.com

EVAPCO West
Madera, CA USA
559.673.2207
contact@evapcowest.com

EVAPCO Alcoil, Inc.
York, PA USA
717.347.7500
info@evapco-alcoil.com

EVAPCO Iowa
Lake View, IA USA

EVAPCO Iowa
Sales & Engineering
Medford, MN USA
507.446.8005
evapcomn@evapcomn.com

EVAPCO LMP ULC
Laval, Quebec, Canada
450.629.9864
info@evapcolmp.ca

EVAPCO Select Technologies, Inc.
Belmont, MI USA
844.785.9506
emarketing@evapcoselect.com

Refrigeration Vessels & Systems Corporation
Bryan, TX USA
979.778.0095
rvs@rvscorp.com

Tower Components, Inc.
Ramseur, NC USA
336.824.2102
mail@towercomponentsinc.com

EvapTech, Inc.
Edwardsville, KS USA
913.322.5165
marketing@evaptech.com

EvapTech Gulf Services
Houston, TX USA
281.529.6526
angie.montes@evaptech.com

EVAPCO Dry Cooling, Inc.
Bridgewater, NJ USA
908.379.2665
info@evapcodc.com

EVAPCO Dry Cooling, Inc.
Littleton, CO USA
908.895.3236
info@evapcodc.com

Asia Pacific

EVAPCO Asia Pacific Headquarters
Baoshan Industrial Zone Shanghai, P.R. China
(86) 21.6687.7786
marketing@evapcochina.com

EVAPCO (Shanghai) Refrigeration Equipment Co., Ltd.
Baoshan Industrial Zone, Shanghai, P.R. China

EVAPCO (Beijing) Refrigeration Equipment Co., Ltd.
Huairou District, Beijing, P.R. China
(86) 10.6166.7238
marketing@evapcochina.com

EVAPCO Air Cooling Systems (Jiaxing) Company, Ltd.
Jiaxing, Zhejiang, P.R. China
(86) 573.8311.9379
info@evapcochina.com

EVAPCO Australia (Pty.) Ltd.
Riverstone, NSW, Australia
(61) 02.9627.3322
sales@evapco.com.au

EvapTech (Shanghai) Cooling Tower Co., Ltd.
Baoshan District, Shanghai, P.R. China.
Tel: (86) 21.6478.0265

EvapTech Asia Pacific Sdn. Bhd.
Puchong, Selangor, Malaysia
(60) 3.8070.7255
marketing-ap@evaptech.com

Europe | Middle East | Africa

EVAPCO Europe EMENA Headquarters
Tongeren-Borgloon, Belgium
(32) 12.39.50.29
evapco.europe@evapco.be

EVAPCO Europe BV
Tongeren-Borgloon, Belgium

EVAPCO Europe, S.r.l.
Milan, Italy
(39) 02.939.9041
evapcoeuropa@evapco.it

EVAPCO Europe, S.r.l.
Sondrio, Italy

EVAPCO Europe A/S
Aabybro, Denmark
(45) 9824.4999
info@evapco.dk

EVAPCO Europe GmbH
Meerbusch, Germany
(49) 2159.69560
info@evapco.de

EVAPCO Middle East DMCC
Dubai, United Arab Emirates
(971) 56.991.6584
info@evapco.ae

Evap Egypt Engineering Industries Co.
A licensed manufacturer of EVAPCO, Inc.
Nasr City, Cairo, Egypt
(20) 10.054.32.198
evapco@tiba-group.com

EVAPCO S.A. (Pty.) Ltd.
A licensed manufacturer of EVAPCO, Inc.
Isando, South Africa
(27) 11.392.6630
evapco@evapco.co.za

South America

EVAPCO Brasil
Equipamentos Industriais Ltda.
Sorocaba, São Paulo, Brazil
(55) 11.5681.2000
vendas@evapco.com.br

FanTR Technology Resources
Sorocaba, São Paulo, Brazil
(55) 11.4025.1670
fantr@fantr.com

TECHNOLOGY FOR THE FUTURE, AVAILABLE TODAY

Visit EVAPCO's website: evapco.com



Introduction

Thank you for purchasing your EVAPCO AT ATLAS induced draft, counterflow cooling tower. This manual provides instructions and recommendations to safely and correctly install all AT ATLAS cooling towers. It is recommended that all instructions provided in this manual are reviewed prior to rigging and assembly. If at any point specific circumstances not covered by this manual arise, please contact your local EVAPCO representative for assistance.

Proper care must be taken by all parties involved in handling and assembling the equipment to ensure that safe and thorough installation practices are implemented to prevent damage or injury to the equipment, persons and environment involved.

Shipping

Unless otherwise noted in the factory submittal, all EVAPCO AT ATLAS towers ship in seven (7) sections per cell plus the drive system, fan, and fan cylinder. Any special shipping configurations will be listed in the factory submittal. Please contact your local EVAPCO representative for more information on alternate shipping configurations.

Nomenclature

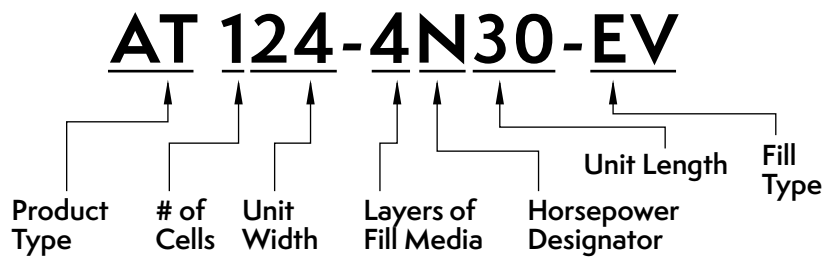

Product Type

AT – Indicates an Advanced Technology (AT) tower.

of Cells

Determined by the number of inlet connections, can be 1 or 2 cells.

Unit Width

The total width of the unit, in feet, all cells included.

Layers of Fill Media

Determined by the number of 1 foot tall fill layers. Can be 4 or 5.

Horsepower Designator

Determined by the horsepower per fan motor. Available from N = 40 HP to T = 150 HP.

Unit Length

The total length of the unit, in feet, all cells included.

Fill Type

Indicates the style of heat transfer media in the tower.

Structural Steel Support

As standard, three structural I-beams running the length of the unit are required for support of each cell. These beams should be located underneath the outer flanges of the unit (See **Figures 1, 1b, 1d**). Transverse steel arrangements are also available (see **Figures 1a, 1c, 1e**). Mounting holes 3/4" (19mm) in diameter are located in the bottom flanges of the unit for bolting to the structural steel (see *steel support print in unit submittal for exact bolt hole location*). Bolt the bottom sections to the steel support before rigging the top sections.

Beams should be sized in accordance with accepted structural practices. Maximum deflection of the beam under the unit to be 1/360th of the unit length, not to exceed 1/2" (13mm). Deflection may be calculated by using 55% of the operating weight of the unit as a uniform load on each beam (See *certified print in unit submittal for operating weight*).

The supporting I-beams should be flush and level before setting the unit. Do not level the unit by shimming between the bottom flanges and the beams as this will not provide proper and continuous longitudinal support. Support beams and anchor bolts are to be furnished by others.

Please refer to the unit submittal for detailed, project specific steel support arrangement.

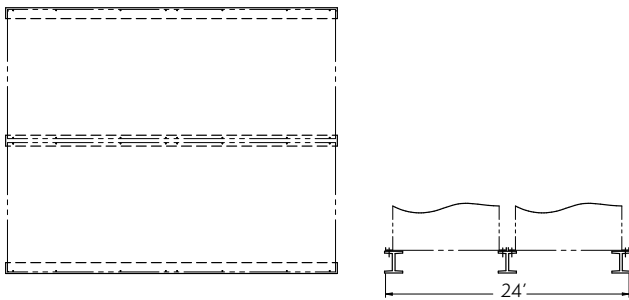

Figure 1 — Standard Longitudinal Steel Support Arrangement for 24' x 30' ATLAS

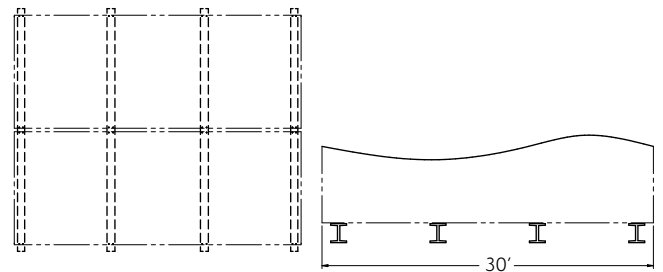

Figure 1a — Standard Transverse Steel Support Arrangement for 24' x 30' ATLAS

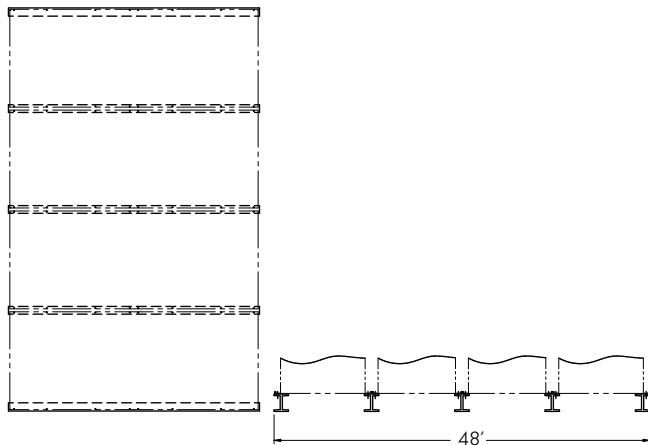

Figure 1b — Standard Longitudinal Steel Support Arrangement for 48' x 30' ATLAS

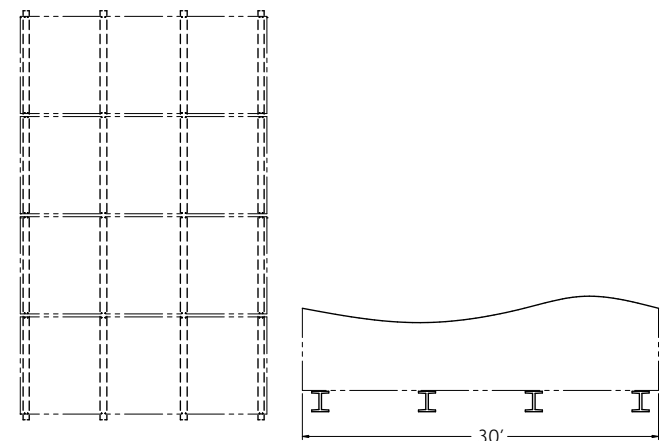

Figure 1c — Standard Transverse Steel Support Arrangement for 48' x 30' ATLAS



Figure 1d — Standard Longitudinal Steel Support Arrangement for 24' x 60' ATLAS

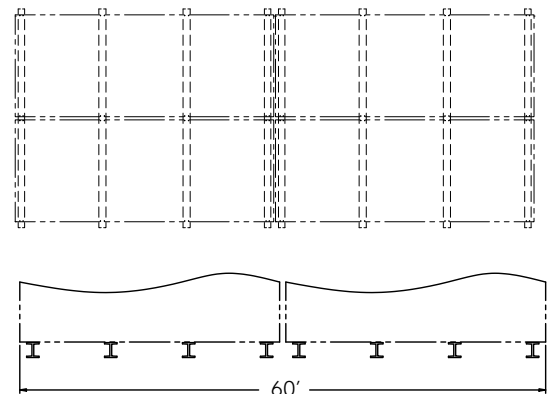

Figure 1e — Standard Transverse Steel Support Arrangement for 24' x 60' ATLAS

Rigging Basin Sections

Lifting devices are located along the inside edges of the bottom section for lifting and final positioning purposes as shown in **Figure 2**. The hook of the crane must be a minimum dimension of 26' above the lifting device to prevent undue strain on the lifting devices. If applicable, see the **Extended Lifts** section on page 13 for proper arrangement.

Bolt the bottom sections to the steel support before rigging the top sections.

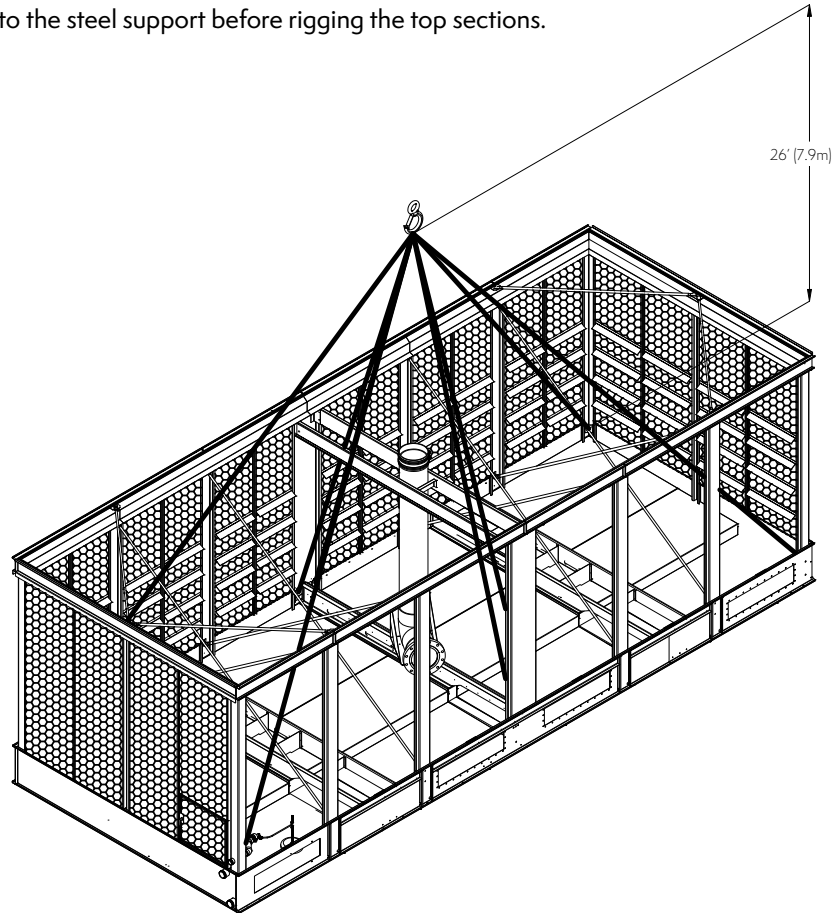

Figure 2 — Rigging Unit Bottom Section - 1 Basin

Joining Bottom Sections

Each 24' x 30' ATLAS basin is composed of two (2) 12' x 30' sections, connected by four (4) flume boxes for equalization.

In addition to the equalizer flumes, these units are provided with horizontal drip channels and vertical splash guards to keep water from splashing out from between the cells.

The equalizer flume boxes are shipped loose for field assembly. It is important to connect the equalizer flumes to balance the water level in the basins for proper pump suction operation. The procedures that follow should be performed in sequence.

ATLAS Flume Box Installation Instructions:

1. Rig one of the bottom sections of the cooling tower. Bolt to steel support.
2. One face of the flume box is provided with 3/8" (10mm) welded bolts. Clean the mating flume opening on the rigged bottom section and apply a layer of sealer tape on this surface, centered between the hole centers and the outside edge. Remove paper backing strip from sealer tape.
3. Align the bolt holes in the rigged bottom section with the welded 3/8" (10mm) bolts on the flume box.
4. Install 3/8" (10mm) nuts and washers on every bolt around the flume opening and tighten.

5. Repeat steps 2-4 for all 4 flume boxes.
6. Rig the second basin adjacent to the equalizer flume on the steel support as shown in **Figure 3**.
7. Clean the mating surfaces of the flume box and the surface of the flume opening on the adjacent section. Apply sealer tape to the flanged flume opening on the adjacent section.
8. Align the bolt holes in the flume box and flume opening with drift pins (by others) while drawing the second bottom section against the flume box.
9. Install 3/8" (10mm) bolts, nuts, and washers in every hole around the flume opening and tighten.
10. Bolt the second bottom section to the steel support.

Drip Channel and Splash Guard Installation Instructions (this may be completed after the unit is completely rigged):

1. Remove the 1/4" (6mm) hardware which holds the drip channel retaining clips to the side panel. Place the drip channel over the adjoining basin section flanges. Turn around the retaining clips and install them using the same hardware.
2. Apply a single layer of sealer tape to the mating flange of the drip channels (see **Figure 3a**). Fasten drip channels together end-to-end by driving a self-tapping 5/16" (8mm) screw through the section end with the larger hole into the mating end with the smaller hole. Stainless steel units will use 5/16" (8mm) stainless steel nuts and bolts.
3. Add sealer tape to bottom of vertical splash guard. Place the vertical splash guard in the bend of the vertical supports. On galvanized units, attach the vertical splash guard using 5/16" (8mm) self-tapping screws. On stainless steel units, attach the vertical splash guards using 5/16" (8mm) stainless steel nuts and bolts. (See **Figure 3**)
4. Once the bottom of the vertical splash guard has been attached to the drip channel, place the filler cap channel in the upper flanges of the basin as shown in **Figure 3**. Attach to vertical splash guards using 5/16" (8mm) tappers (for galvanized units) or stainless steel nuts and bolts (for stainless steel units).

Filler Cap Channel to be installed after the casing sections are rigged.

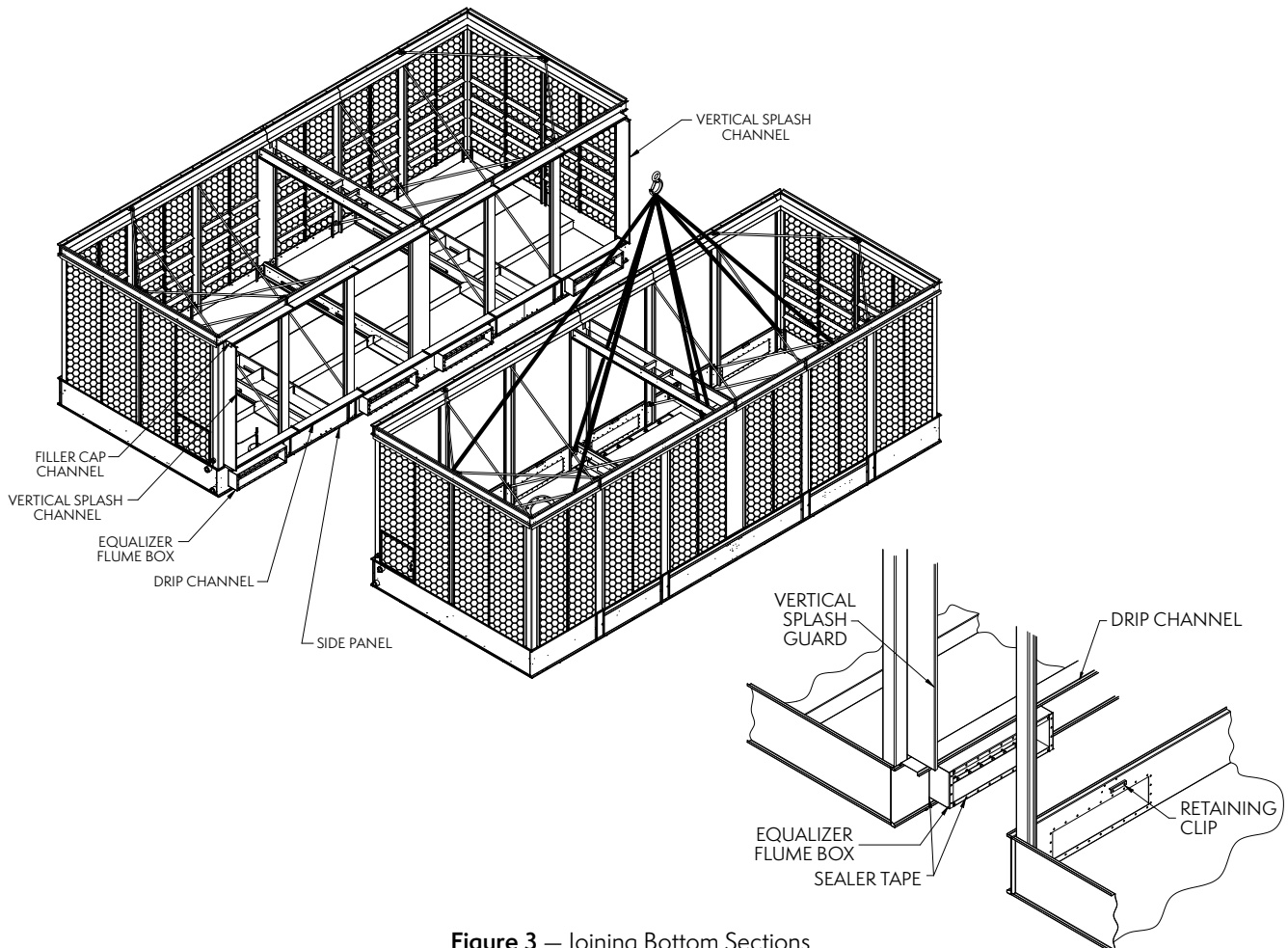

Figure 3 — Joining Bottom Sections

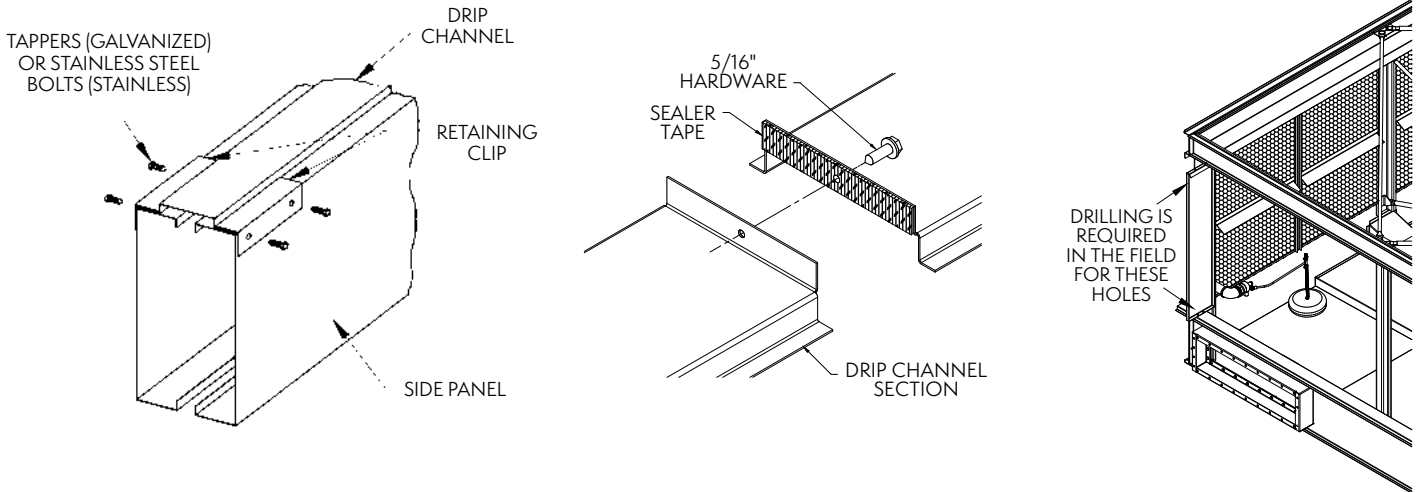

Figure 3a – Drip Channel and Vertical Splash Guard Installation

Outlet Piping

Side outlet depressed sump boxes ship loose in the basin and require installation in field. Please follow below instructions to complete installation of the side outlet depressed sump box:

1. Locate square opening in the deepest part of the tower's basin. Clean mating surface, and apply sealer tape over the bolt holes surrounding the opening, as shown in **Figure 4**.
2. Lower the side outlet depressed sump box through the opening such that the bolt holes on its flanges match up with the holes surrounding the opening.
3. Complete installation using provided hardware in **Table 1**, as shown in DETAIL A and DETAIL B.

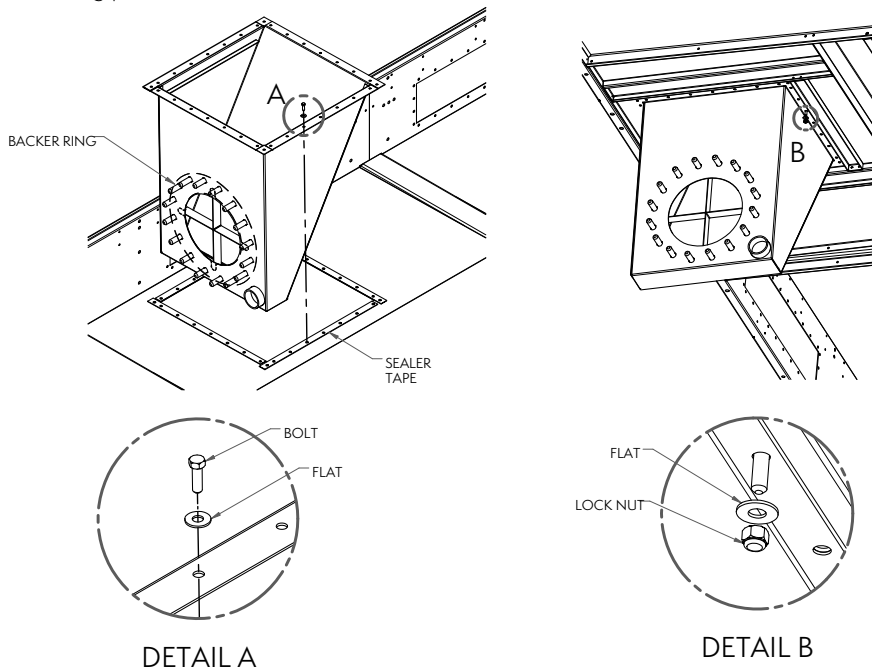

Figure 4 – Side Outlet Depressed Sump Box Installation

Units	Hardware Sizes
All ATLAS Units	3/8" (10mm) Nuts, Bolts & Washers (Galvanized or Stainless)

Table 1 – Hardware Sizes

Application of Sealer Tape to Basin Sections

Once the basin sections have been set on the support steel and all fasteners are installed, the top flanges should be wiped down to remove any dirt or moisture. Apply one layer of sealer tape along the 12' and 30' sides, centered over the mounting hole (see **Figure 5**). The sealer tape should overlap on the corners as shown in **Figure 5**. Do not splice the sealer tape along the 12' long end flanges. Sealer tape will need to be spliced and overlapped on the 30' sides.

Always remove the paper backing from the sealer tape.

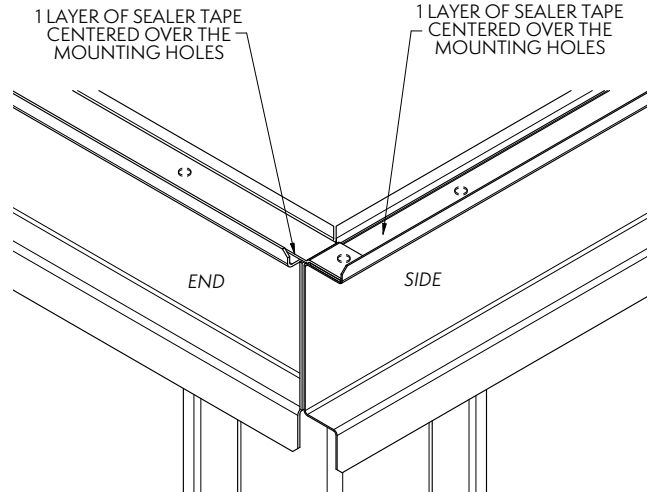

Figure 5 — Sealer Tape on Flange of Basin Section

Rigging Casing Sections

Lifting ears are provided in the corners of the casing sections and along the length (4 total lifting ears per side) for lifting and final positioning. The hook of the crane must be a minimum dimension 26' above the casing sections to prevent undue strain on the lifting ears.

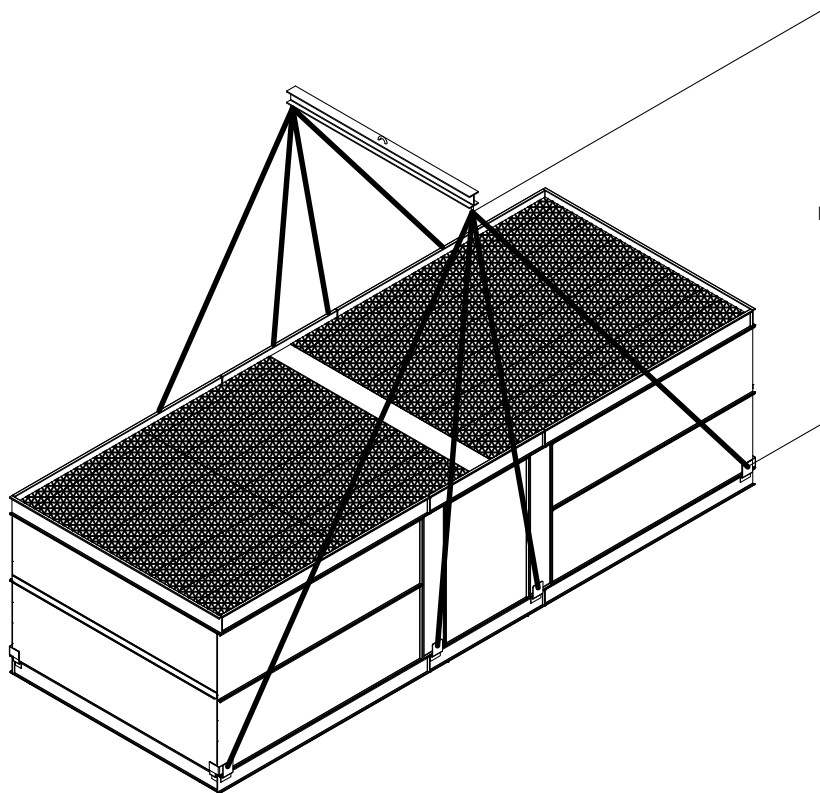

Figure 6 — Rigging a Unit Casing Section



Assembly of the Casing Sections to the Basin Sections

Before securing the casing sections to the basin sections, remove any loose parts shipped in the basin.

Wipe the flanges on the bottom of the casing sections. Review the match markings on the casing and basin sections, as outlined in Appendix A, to verify that the casing section is installed in the correct position.

Lower the casing section to within several inches of the basin section making sure the two sections do not touch and the sealer tape is not disturbed. Lower the casing section the rest of the way and fasten all four corners. See **Table 2** for recommended hardware. Make use of drift pins to simplify the final positioning process (see Drift Pin explanation below).

Install the remaining fasteners, working from the corners towards the center. Fasteners must be installed in every hole in the flanges.

Use of Drift Pins for Final Positioning

Drift pins are tools used to align holes in the flanges of the casing and basin sections of the unit prior to final fastening. They are occasionally used in the positioning of the basin section as well.

Once the sealer tape is applied and the casing section is hovering over the basin section, a drift pin should be driven into each of the corner bolt holes. Using drift pins in the corners (at minimum) is meant to restrict the sideways motion of the casing section relative to the basin section.

A drift pin should be used in intermediate bolt holes in the rigging seams as needed to maintain alignment.

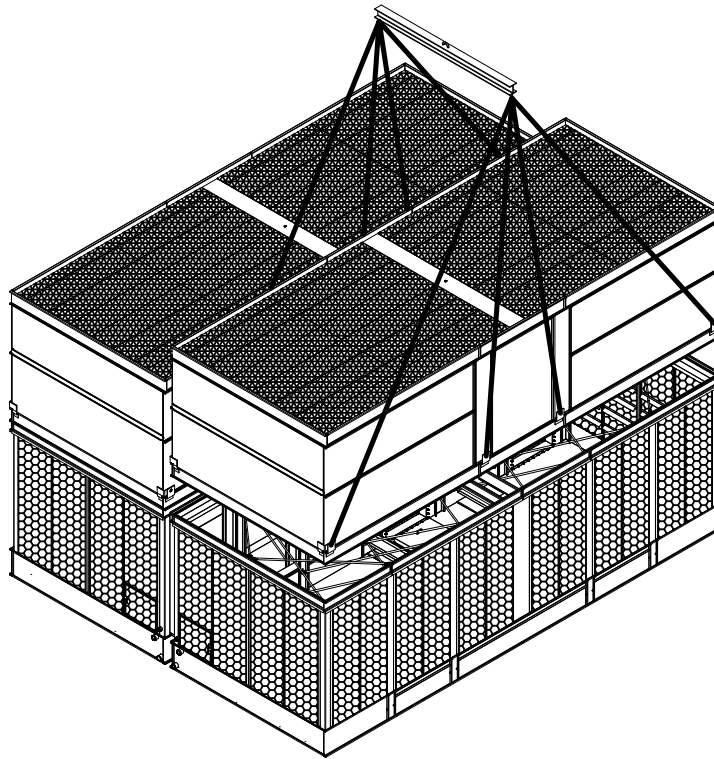

Figure 7 – Assembling Casing and Basin Sections

Units	Hardware Sizes
All ATLAS Units	3/8" (10mm) Nuts, Bolts & Washers (Galvanized or Stainless)

Table 2 – Hardware Sizes

Assembly of Bottom Inlet Piping

On the ATLAS tower, the inlet connection is located on the bottom as standard. Internal piping is provided that allows the process water to make its way to the hot water distribution system. Please follow the below steps to complete field installation of the bottom inlet after the unit is rigged.

1. On the ATLAS tower, the inlet connection is located on the bottom as standard.
2. Locate the bottom inlet assembly components, namely the riser pipes, one flexible reinforced pipe connector per riser, four pipe clamps per riser, and the lower pipe flanged spool.
 - 2a. Remove shipping strap under pipe.
 - 2b. Install flexible connectors and clamps on lower inlet pipe prior to rigging.**
3. Align the riser pipe assembly with the upper pipe section in the bottom of the casing section. Loosen the pipe clamp and slip the pipe connector up over the upper pipe section.
4. Tighten all pipe clamps. A ratchet wrench is recommended (See **Figure 8**).
5. Repeat this process for each riser pipe.
6. After tower is fully installed, insert the lower pipe flanged spool with gaskets between flanges, as shown in **Figure 9**. Use hardware noted in **Table 3**. Please note, the basin section has cross braces for shipping support. One of these cross braces will be in the way of the pipe spool, please remove this cross brace prior to installing the pipe spool. The cross brace does **NOT** need to be reinstalled after the pipe spool has been installed.

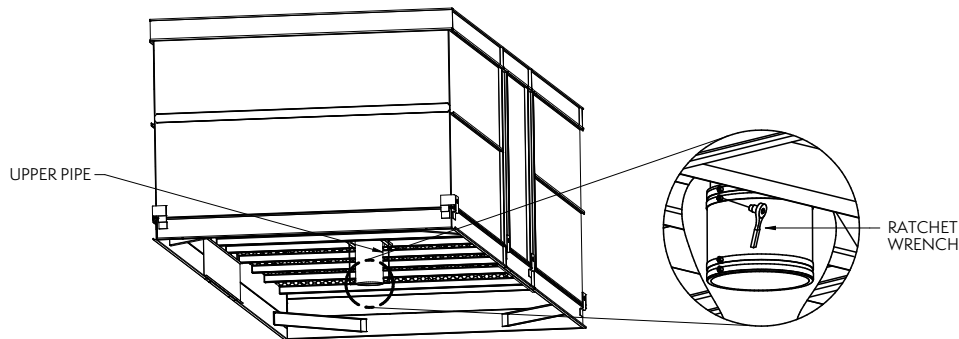

Figure 8 – Casing Bottom Inlet Piping

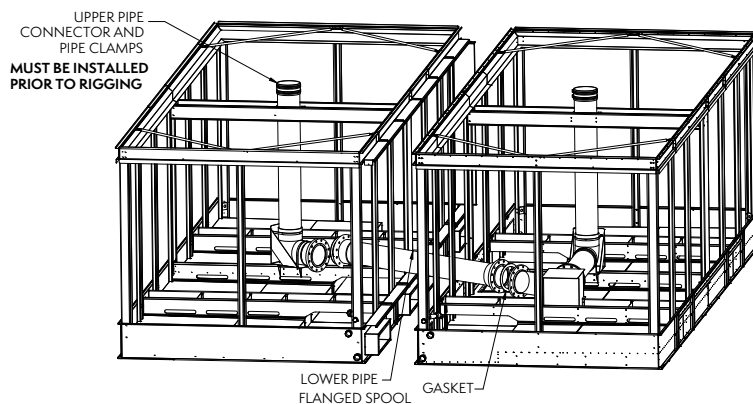

Figure 9 – Installation of Bottom Inlet Piping

Units	Hardware Sizes
All ATLAS Units	7/8" (22mm) Nuts, Bolts & Washers (Galvanized or Stainless)

Table 3 – Hardware Sizes



A weep hole, as shown in **Figure 10**, is provided to drain internal piping during pump shut down. It is recommended to remove the drain plug during cold weather operation. The drain plug ships loose in the rigging box.

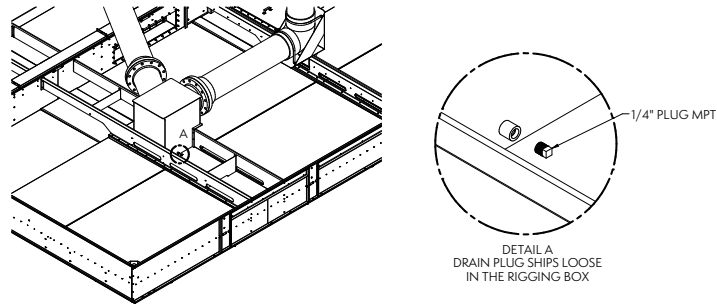

Figure 10 — Weep Hole

Application of Sealer Tape to Casing Sections

Once the casing sections have been rigged to the basin sections and all fasteners are installed, the top flanges should be wiped down to remove any dirt or moisture. Apply one layer of sealer tape, centered over the mounting holes (see **Figure 11**). On the flanges between casing sections, apply two strips of sealer tape, one partially overlapping the other on the entire length of the flanges. Apply sealer tape to the entire perimeter of the casing sections. Do not splice the sealer tape along the 12' long end flanges. Sealer tape will need to be spliced and overlapped on the 30' sides.

Always remove the paper backing from the sealer tape.

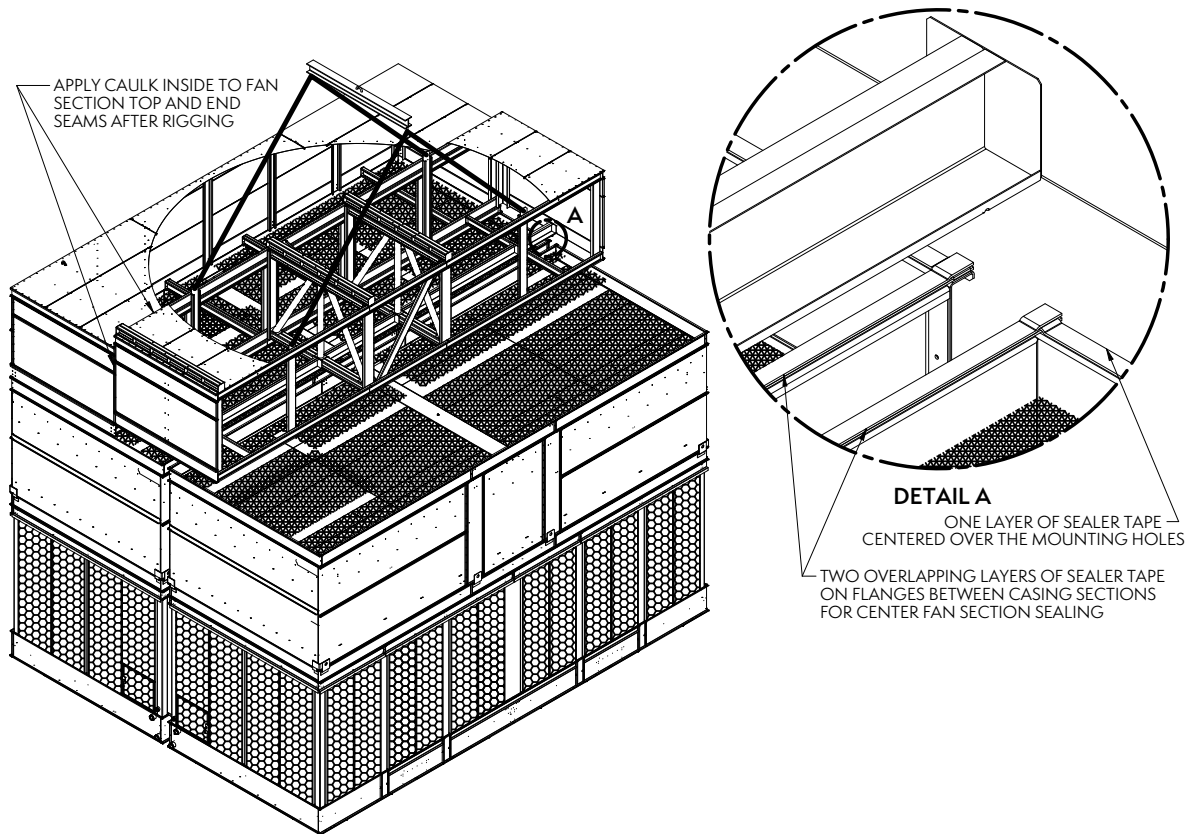

Figure 11 — Fan to Casing Section Sealing

Rigging Fan Sections

Each ATLAS unit has 3 fan sections: left, right and middle. On the middle section, lifting ears are provided for lifting and final positioning. For the left and right sections, U-bolts are provided. The hook of the crane must be a minimum of 26' above the lifting device to prevent undue strain on the lifting ears and U-bolts. See **Figures 12a** and **12b** for the middle section and end sections, respectively.

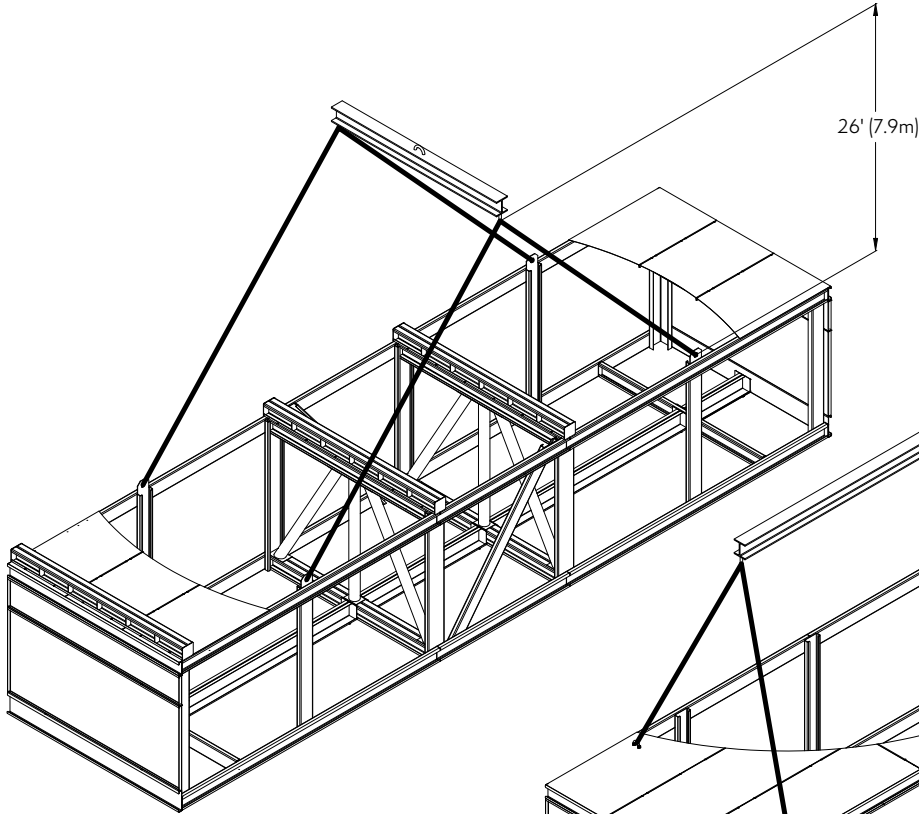

Figure 12a — Rigging of Middle Fan Module

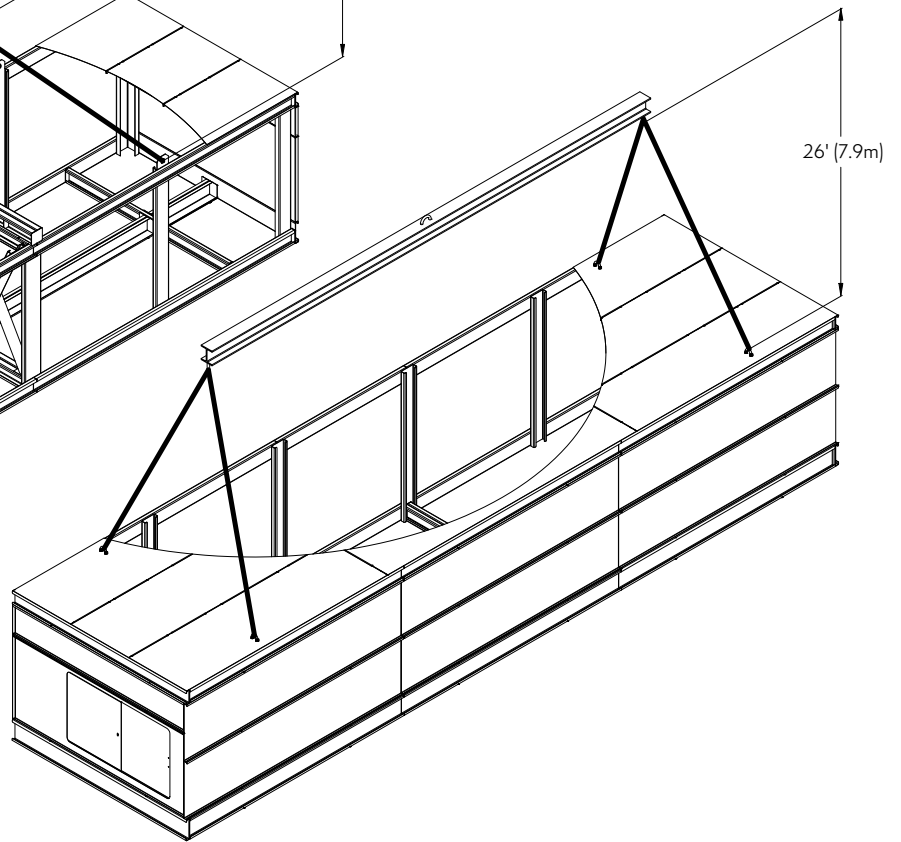

Figure 12b — Rigging of End Fan Module



Assembly of the Fan Sections to the Casing Sections

The fan sections rigging should begin with an end fan module, followed by the middle fan module and finally followed by the last end fan module.

Drift pins should be used to align the fan section with the casing section. The installer will need to attach the fan section end panels to the casing section end panels and the fan section side panels to the casing section side panels with 3/8" (10mm) hardware.

Units are provided with match markings on each section to assist with arrangement, as shown in Appendix A.

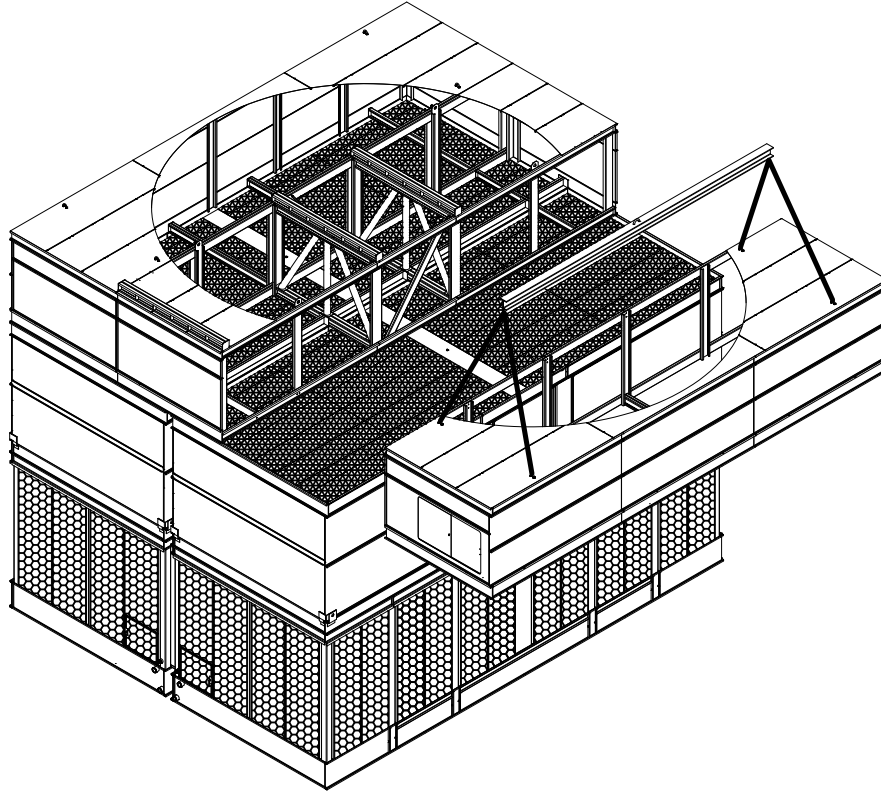

Figure 13 – Assembling Fan and Casing Sections

Rigging Fan Sections on Multi-cell Units

On multi-cell installations, placing multiple towers side-by-side will limit access between cells. Therefore, multi-cell rigging channels will come attached to the inside of the casing and fan section panels, as shown in **Figure 14**. Once the sections are mounted, the flanges of the rigging channels must be bolted from inside the unit. Use hardware noted in **Table 4**. The fasteners in the rigging channels are in addition to the fasteners required around the perimeter of the fan section.

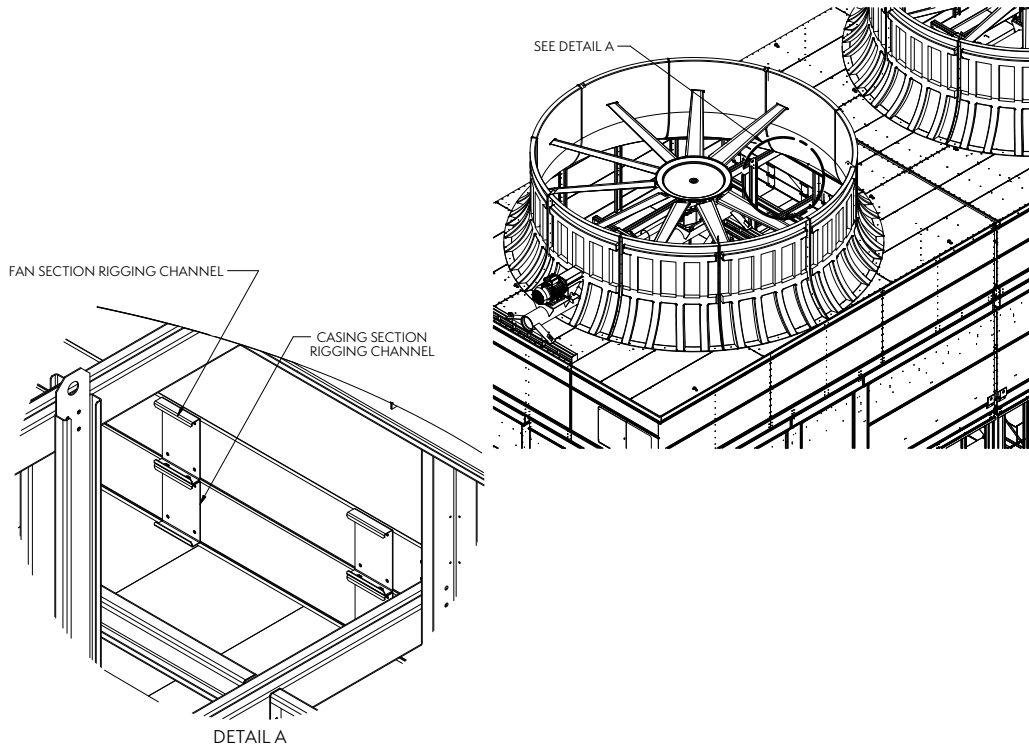

Figure 14 — Fan and Casing Rigging - Multi-cell

Units	Hardware Sizes
All ATLAS Units	3/8" (10mm) Nuts, Bolts & Washers (Galvanized or Stainless)

Table 4 — Hardware Sizes

Fan Sealing

After rigging, apply caulk to the top and end seams of the fan sections (**Figure 15**). This must be done from the inside of the unit.

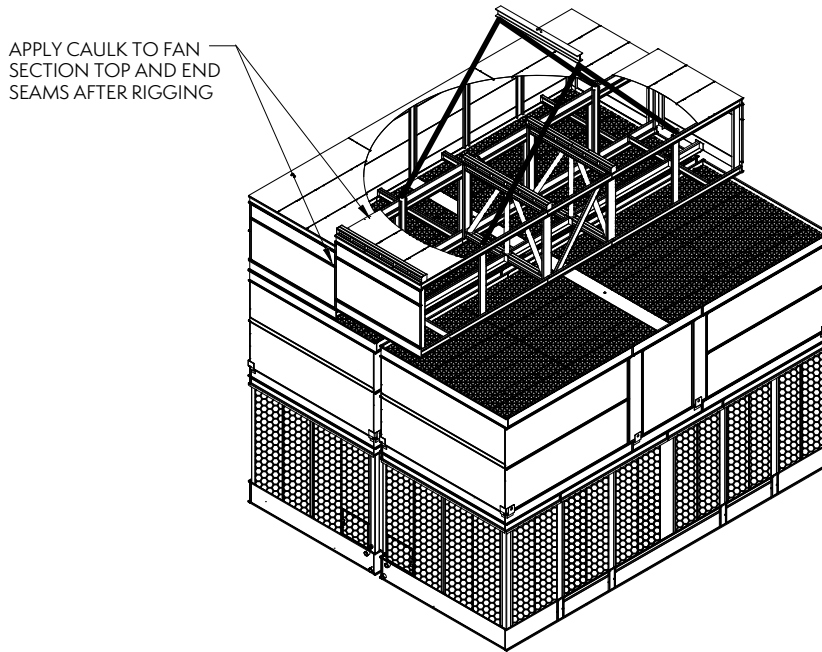

Figure 15 — Fan Section Sealing

Extended Lifts

NOTE: The lifting devices and U-bolts should be used for final positioning only and for lifting where no danger exists. If they are used for extended lifts, safety slings should be provided under the sections.

Safety slings and skids must be removed before final positioning of the unit.

The preferred method for extended lifts is to use slings under the unit, as shown in **Figure 16** below. Spreader bars should always be used between the cables at the top of the section to prevent damage to the upper flanges.

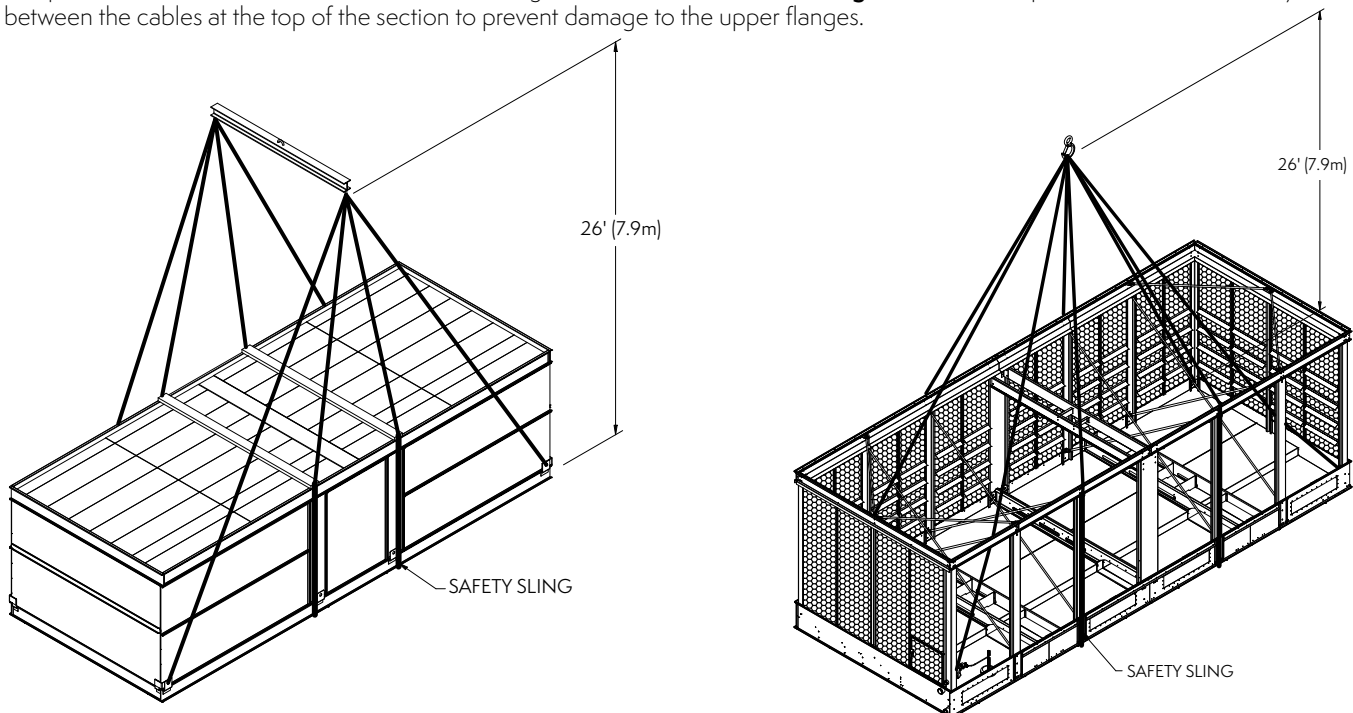

Figure 16 — Extended Lifts

Floating Shaft Installation & Alignment

The fan motor and gear reducer will ship mounted to the mechanical equipment support. Floating shaft ships uninstalled, to prevent damage. The system will be prealigned in the factory; however, alignment should be verified prior to rigging the mechanical equipment support to the fan section.

The steps for installation and alignment of the floating shaft are:

1. Install motor segment seal sheet between the floating shaft and mechanical support. See section “Motor Segment Seal Sheet Installation” on page 23.
2. Mount the drive shaft with the flexible element assembly on the gear drive input shaft using the supplied 3/8” (10mm) hardware. All bolts, lock washers and nuts are supplied with the drive shaft kit.
3. Insert steel bushings into the composite flexible elements on the motor side.
4. Mount the drive shaft with the flexible element assembly on the motor output shaft using the supplied 3/8” (10mm) hardware. All bolts, lock washers and nuts are supplied with the drive shaft kit.
5. Torque requirements for the bolts are listed in **Table 5** (these values are dependent upon the shaft model). Use a torque wrench to properly torque all drive shaft bolts.

Shaft Model	Torque Requirement
LR_350	400 in-lbs/33 ft-lb/45 Nm
LR_375	400 in-lbs/33 ft-lb/45 Nm
LR_450	145 in-lbs/12 ft-lb/16 Nm
LR_485	240 in-lbs/20 ft-lb/27 Nm
LR_650	400 in-lbs/33 ft-lb/45 Nm

Table 5 – Torque Requirements for Floating Shaft Assemblies

6. Check angular and axial misalignment between the drive shaft and both the motor and gear drive couplings. (**Figure 17**)

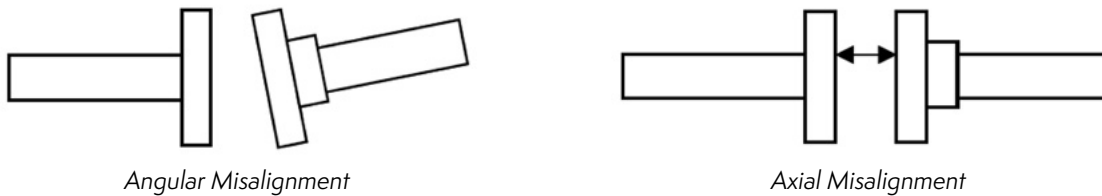

Figure 17 – Checking Angular and Axial Misalignment

7. Check angular misalignment with a dial indicator on gear drive side.
8. Attach the dial indicator support to the drive shaft and position the indicator tip to read off the opposite side flange.
9. With the dial indicator set to zero, rotate the shaft 360° and record the indicator readings at 90° increments.
10. The range between minimum and maximum values should be less than 0.010” (0.25mm). If alignment is out of tolerance, add shims (not exceeding 1/4”).
11. When the angular alignment is within the acceptable ranges as mentioned in step 9, securely tighten all gear drive hardware.
12. Repeat steps 6 through 10 on the motor side of the drive shaft.
13. Check axial misalignment with a tape measure or dial caliper. Refer to **Table 6** for axial alignment gap limits.

Shaft Model	Axial Alignment Gap Limits
LR_350	0.42-0.44 in. (10.7mm-11.2mm)
LR_375	0.53-0.55 in. (13.5mm-14.0mm)
LR_450	0.42-0.44 in. (10.7mm-11.2mm)
LR_485	0.58-0.62 in. (14.9mm-15.9mm)
LR_650	0.73-0.77 in. (18.5mm-19.6mm)

Table 6 – Axial Alignment Gap Limits

Fan Assembly Instructions

Once the gear drive has been aligned the fan should be assembled onto the mechanical equipment assembly. This simplifies assembly by completing it at ground level and reducing the number of lifts required.

Hudson Fan:

Please see "Tuf-Lite® III Fans 4000KW Series Hub Installation Manual", **Figure 18** and **Table 7**.

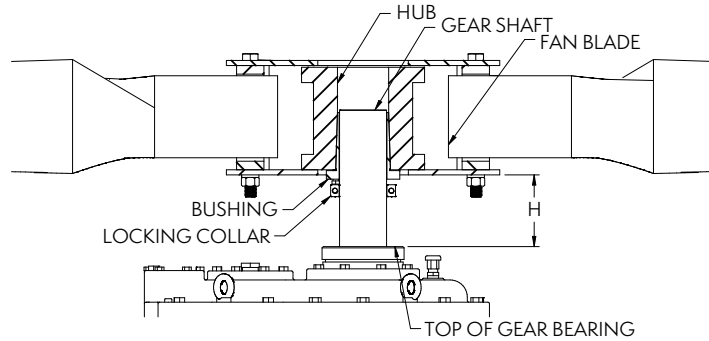

Figure 18 – Hudson Fan Mounting

Gear Drive	"H"
1008	8.5"
1110	7"
1311	6"

Table 7 – Hudson Fan Hub Distance

Moore Fan (Class 10000):

Please see "Moore Fans Class 10000 Fans Owners Manual", **Figure 19** and **Table 8**.

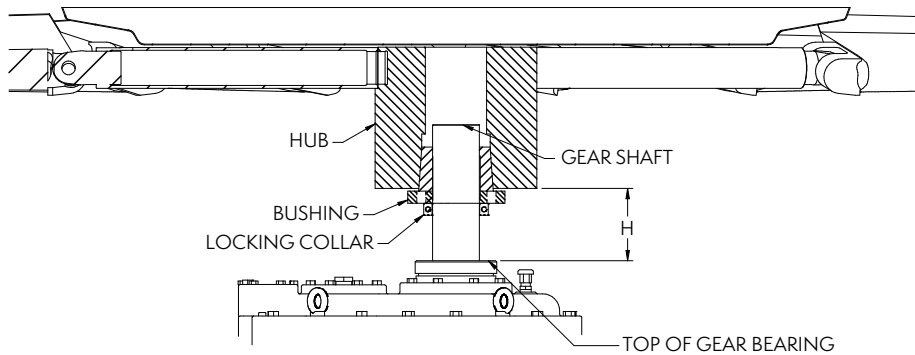

Figure 19 – Moore Fan Mounting

The relevant, above-mentioned manuals will be sent along with the tower.

Gear Drive	"H"
1008	7"
1110	6"
1311	5"

Table 8 – Moore Fan Hub Distance

Fan Assembly Instructions

Super Low Sound Fan (Moore Mag):

Please see "Moore Fans Class 1000 MAG Installation Instructions", **Figure 20** and **Table 9**.

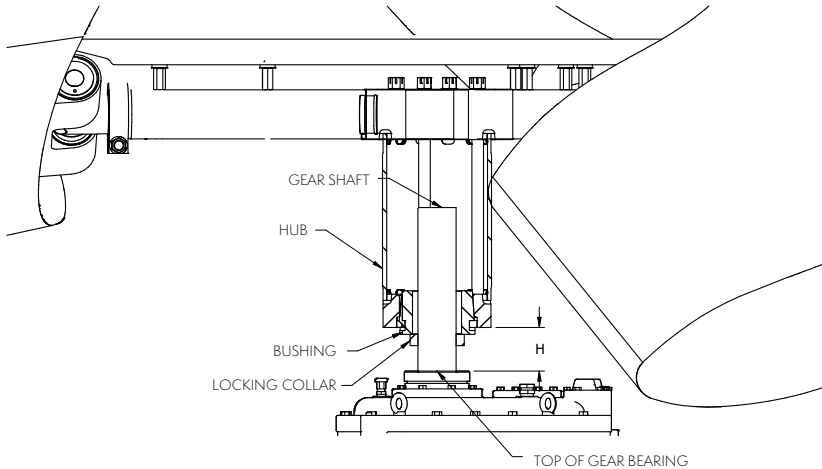

Figure 20 – Super Low Sound Fan

Gear Drive	"H"
1008	12"
1110	11"
1311	10"

Table 9 – Super Low Sound Fan Hub Distance

Rigging Drive Assembly

Once the gear drive has been aligned and the fan assembled onto the gear output shaft, the entire assembly should be lifted onto the fan section (**Figure 21**). The hook of the crane must be a minimum of 17' above the lifting ears. See **Table 10** for hardware required to attach the drive assembly to the fan deck. Be sure to position the lifting cables between fan blades so as not to damage the fan during the lift.

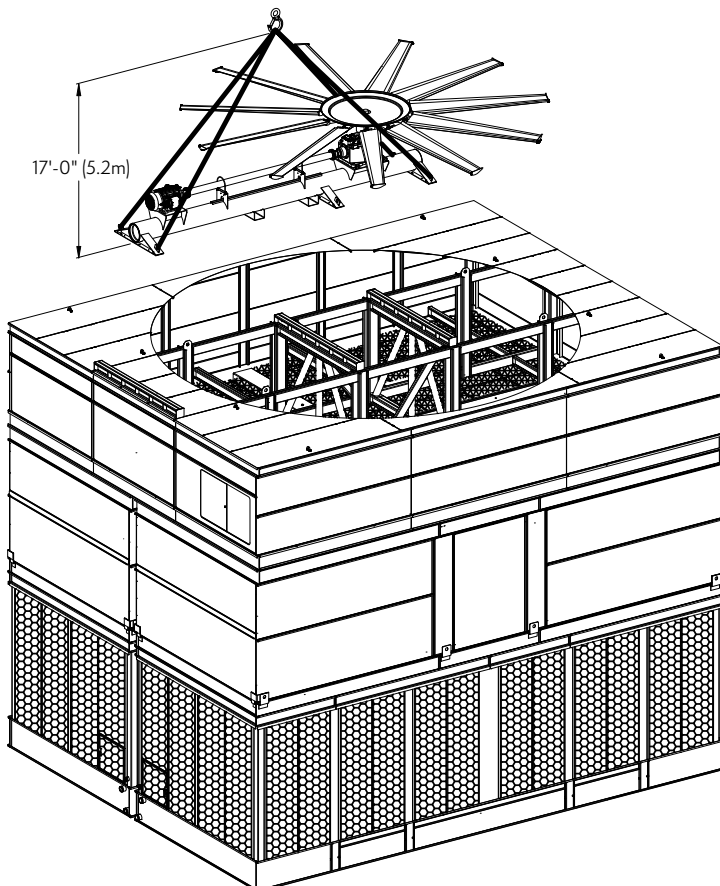

Figure 21 – Rigging Drive System

Units	Hardware Sizes
All ATLAS Units	1/2" (13mm) Nuts, Bolts & Washers (Galvanized or Stainless)

Table 10 – Hardware Sizes



Standard Fan Cylinder Assembly

If units are supplied with super low sound fan, skip to Page 19.

The fan cylinder will ship in 10 sections for assembly and installation in the field. Join each section with the flanges as shown in **Figures 22 and 23** (flanges should be cleaned prior to assembly). Fan cylinder assembly should be performed on the ground with one person holding the sections up until the assembly is able to stand alone. See **Table 11** for hardware required to assemble the fan cylinder.

Lifting devices are integrated into each cylinder section. After cylinder is assembled, attach rib stiffeners and top ring stiffeners as shown in **Figure 22** on the following page.

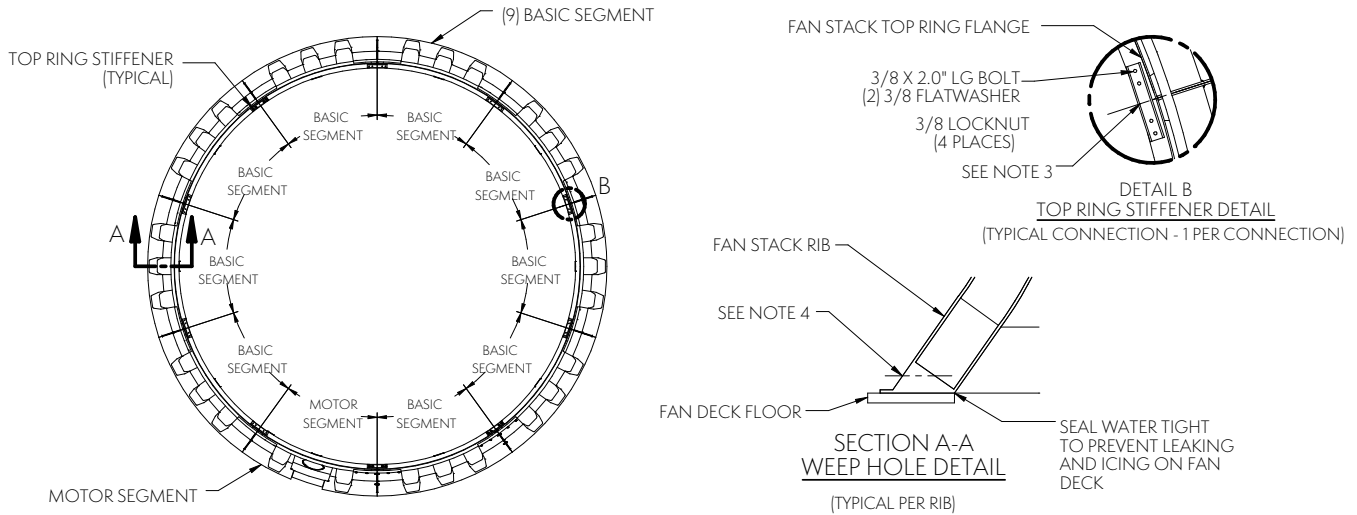

Figure 22 — Typical Fan Stack Plain View

NOTE:

1. FIELD FABRICATE ALL MATERIALS AS REQUIRED FOR PROPER INSTALLATION.
2. DO NOT OVER-TIGHTEN BOLTS. STOP BOLTING IMMEDIATELY IF FRP STARTS TO DEFORM.
3. ALIGN RING STIFFENER TO SEGMENT JOINT USING CENTERLINE MARK PROVIDED. FIELD DRILL SEGMENT TOP FLANGE USING STIFFENER AS TEMPLATE.
4. FIELD DRILL A 9/16" DIA HOLE IN EACH RIB, IF NOT PRE-DRILLED FROM FACTORY.
5. FIELD DRILL SEGMENT BASE USING HOLES IN FAN DECK AS A TEMPLATE.

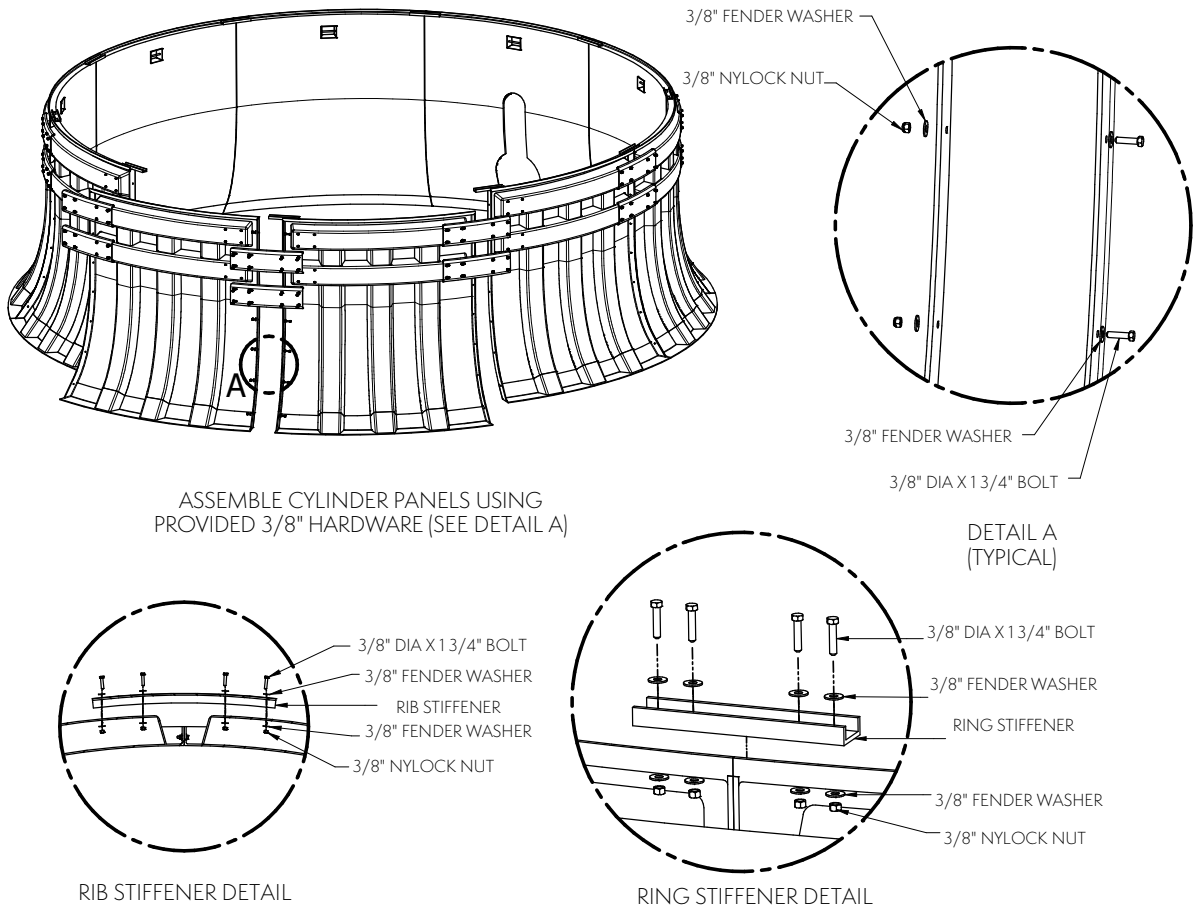

Figure 23 – Fan Cylinder Assembly

Units	Hardware Sizes
All ATLAS Units	3/8" (10mm) Nuts, Bolts & Washers

Table 11 – Hardware Sizes



Super Low Sound Fan Cylinder Assembly

The fan cylinder will ship in 20 sections for assembly and installation in the field. Join each section with the flanges as shown in **Figures 24 and 25** (flanges should be cleaned prior to assembly). Fan cylinder assembly should be performed on the ground with one person holding the sections up until the assembly is able to stand alone. See **Table 11** for hardware required to assemble the fan cylinder.

Lifting devices are integrated into each cylinder section. After cylinder is assembled, attach rib stiffeners as shown in **Figure 25** on the following page. Be sure to include diagonal support mounts on top of rib stiffeners.

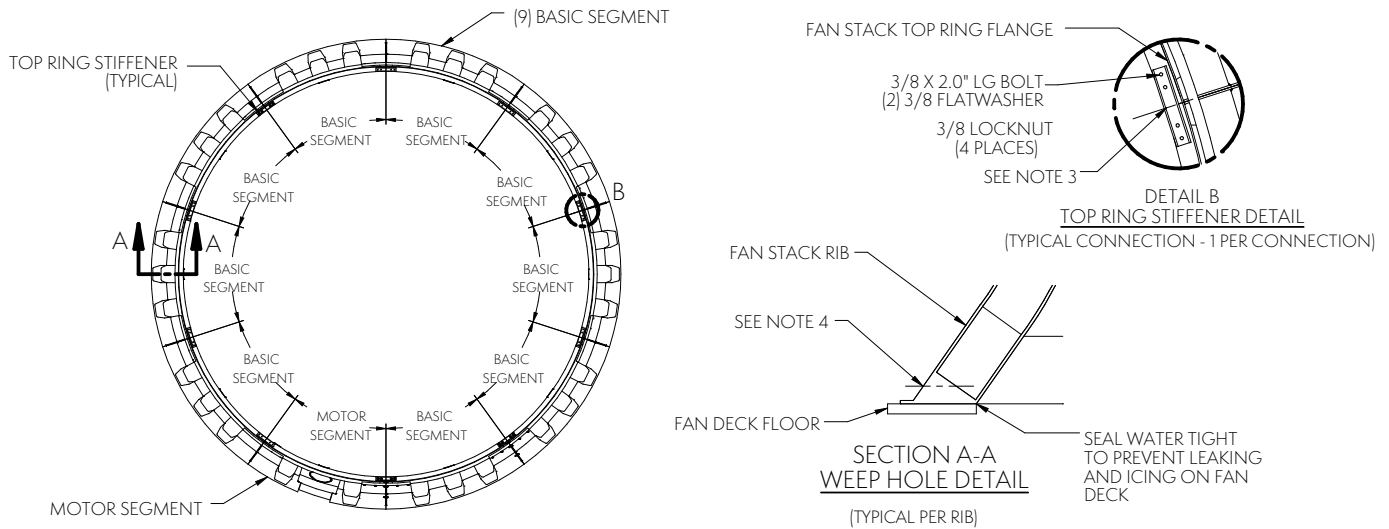

Figure 24 — Typical Super Low Sound Fan Stack Plain View

NOTE:

1. FIELD FABRICATE ALL MATERIALS AS REQUIRED FOR PROPER INSTALLATION.
2. DO NOT OVER-TIGHTEN BOLTS. STOP BOLTING IMMEDIATELY IF FRP STARTS TO DEFORM.
3. ALIGN RING STIFFENER TO SEGMENT JOINT USING CENTERLINE MARK PROVIDED. FIELD DRILL SEGMENT TOP FLANGE USING STIFFENER AS TEMPLATE.
4. FIELD DRILL A 9/16" DIA HOLE IN EACH RIB, IF NOT PRE-DRILLED FROM FACTORY.
5. FIELD DRILL SEGMENT BASE USING HOLES IN FAN DECK AS A TEMPLATE.

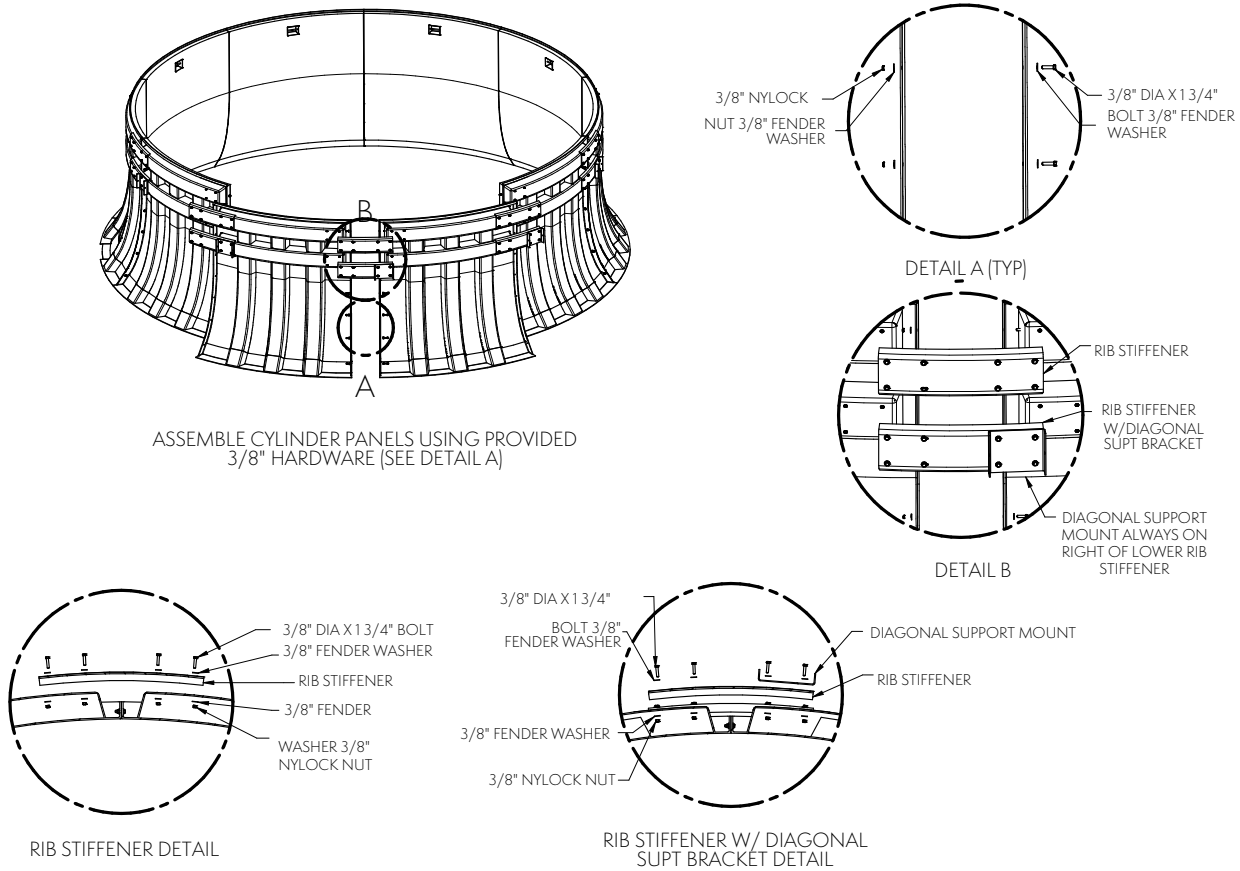

Figure 25 — Super Low Sound Fan Lower Cylinder Assembly



AT ATLAS INDUCED DRAFT MODULAR COUNTERFLOW COOLING TOWERS

If the unit is supplied with a super low sound fan, an extension section is required on top of a standard cylinder.

Assemble extension one section at a time on top of the lower section. Install all hardware, but do not tighten until all sections are installed. After all sections are installed, check for roundness, make any adjustments, then tighten all hardware.

After extension section is assembled, attach rib stiffeners and top ring stiffeners as shown below.

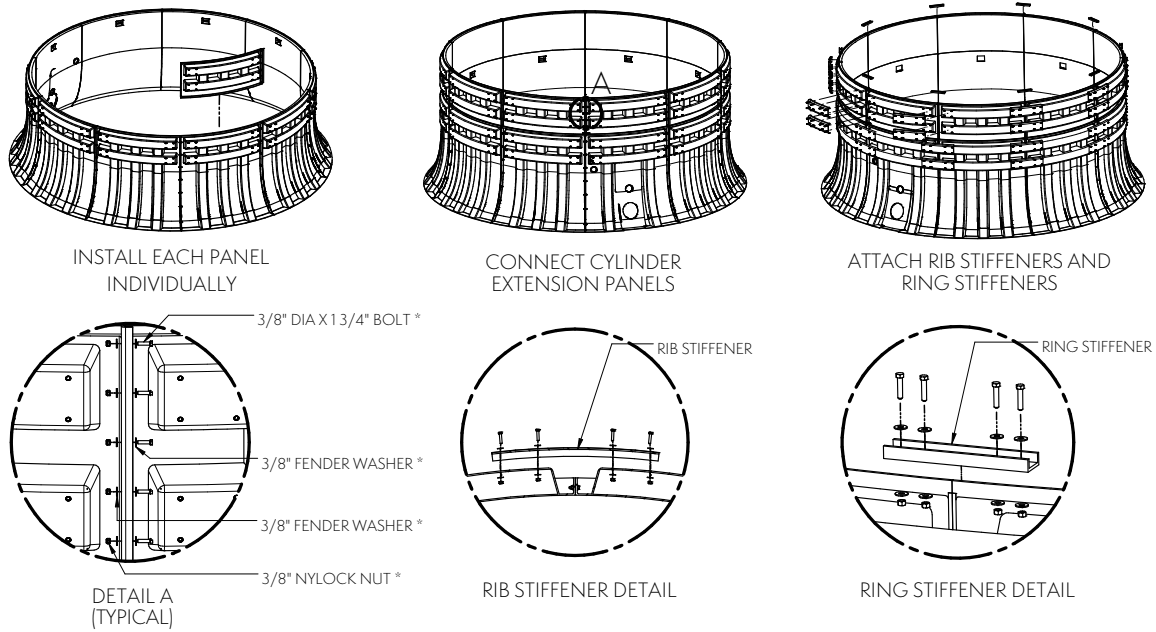

Figure 26 — Super Low Sound Fan Upper Cylinder Assembly

***NOTE:** 3/8" Hardware is typical in all locations. Attach all hardware loosely and only tighten once all components are assembled as to maintain circularity and proper fit.

Fan Cylinder Rigging

Lift the cylinder, utilizing every other lifting device for a total of 5 pick points. The hook of the crane must be a minimum of 13' above the lifting devices. Lower cylinder carefully around fan and drive shaft using the provided lifting devices. Make sure fan assembly is centered within the cylinder before attaching to fan section. Measure the clearance between each fan tip and the cylinder with a tape measure, making sure it is 7/8" (22mm) or less.

Fasten to fan deck using hardware in **Table 12**. Holes are to be drilled through the cylinder and fan deck in the field from outside the tower.

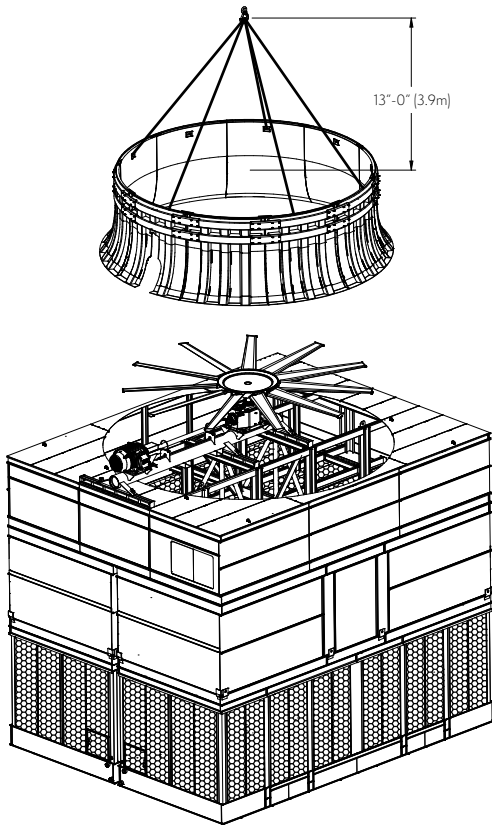

Figure 27 — Standard Fan Cylinder Rigging

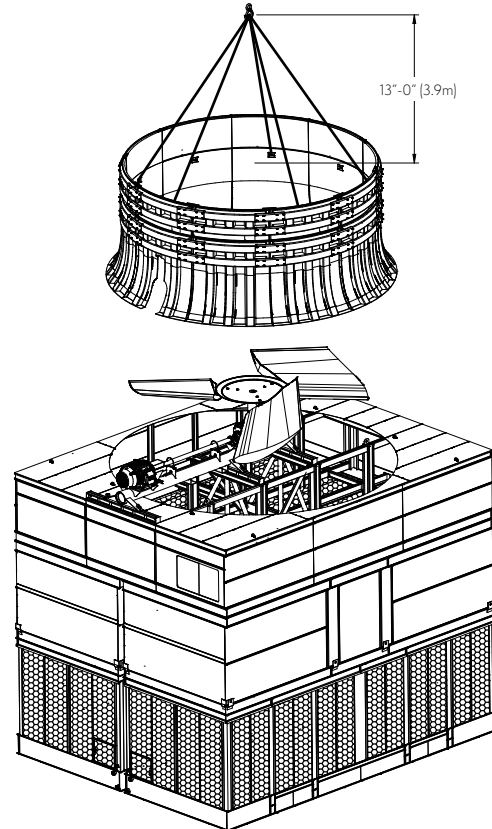

Figure 28 — Super Low Sound Fan Cylinder Rigging

Units	Hardware Sizes
All ATLAS Units	3/8" (10mm) Nuts, Bolts & Washers (Galvanized or Stainless)

Table 12 — Hardware Sizes

Motor Segment Seal Sheet Installation

After fan cylinder is rigged, install Seal Sheets where mechanical support goes through cylinder.

Install Sheet 1 between mechanical support and floating shaft. This can be performed before the installation of the floating shaft.

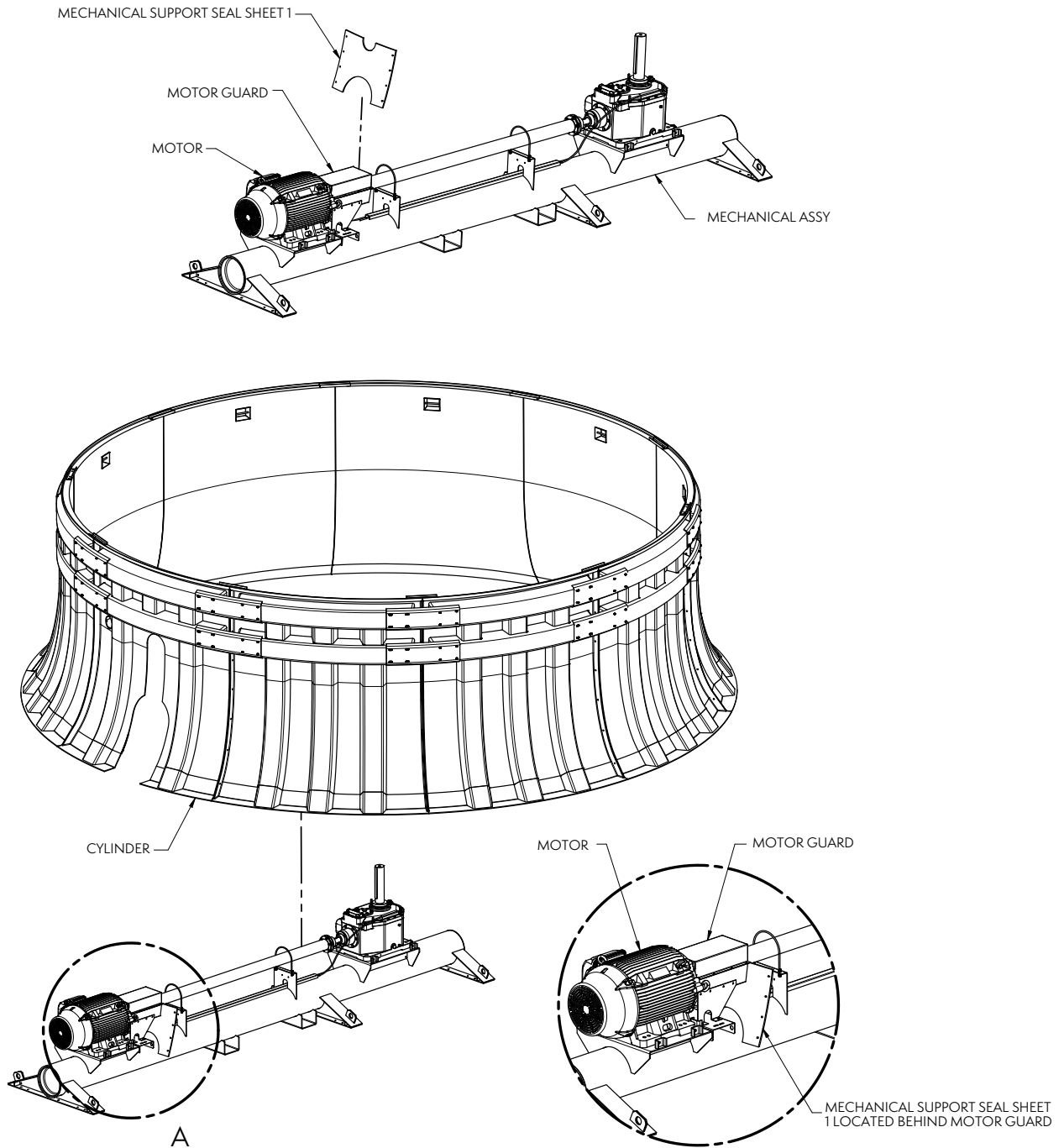

Figure 29 – Seal Sheet 1 Assembly

Install Sheet 2 under the mechanical support and Driveshaft Seal Sheet above the driveshaft.

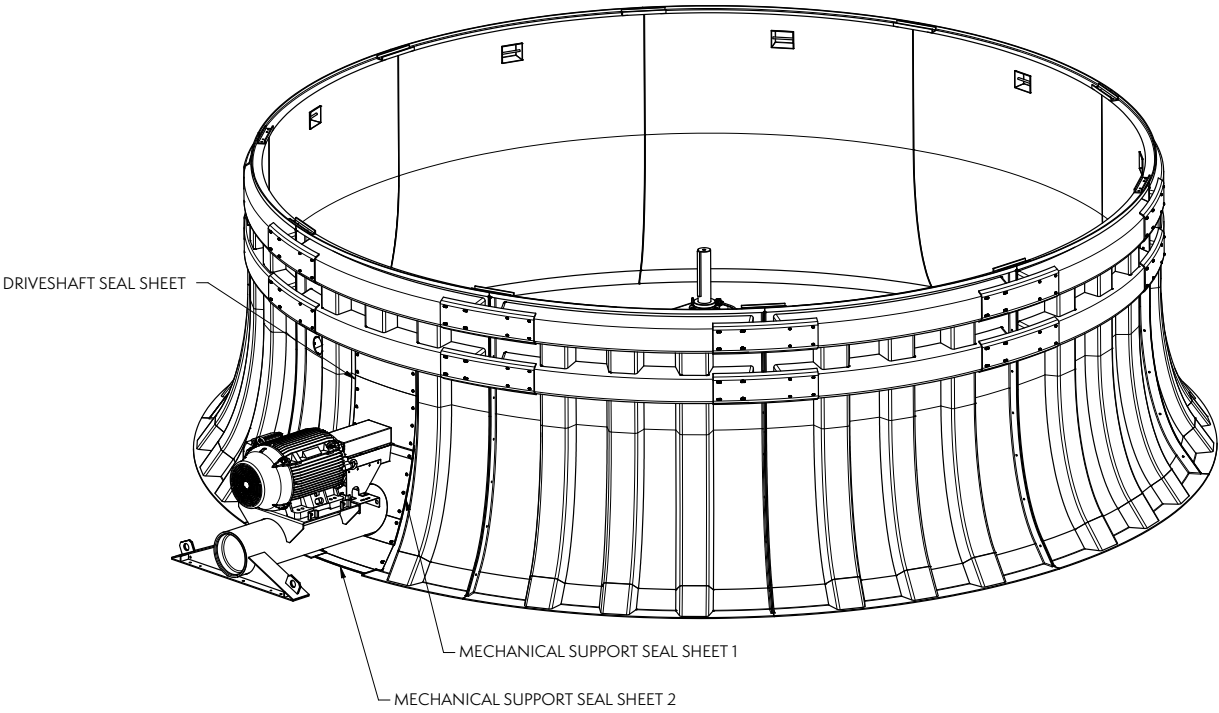
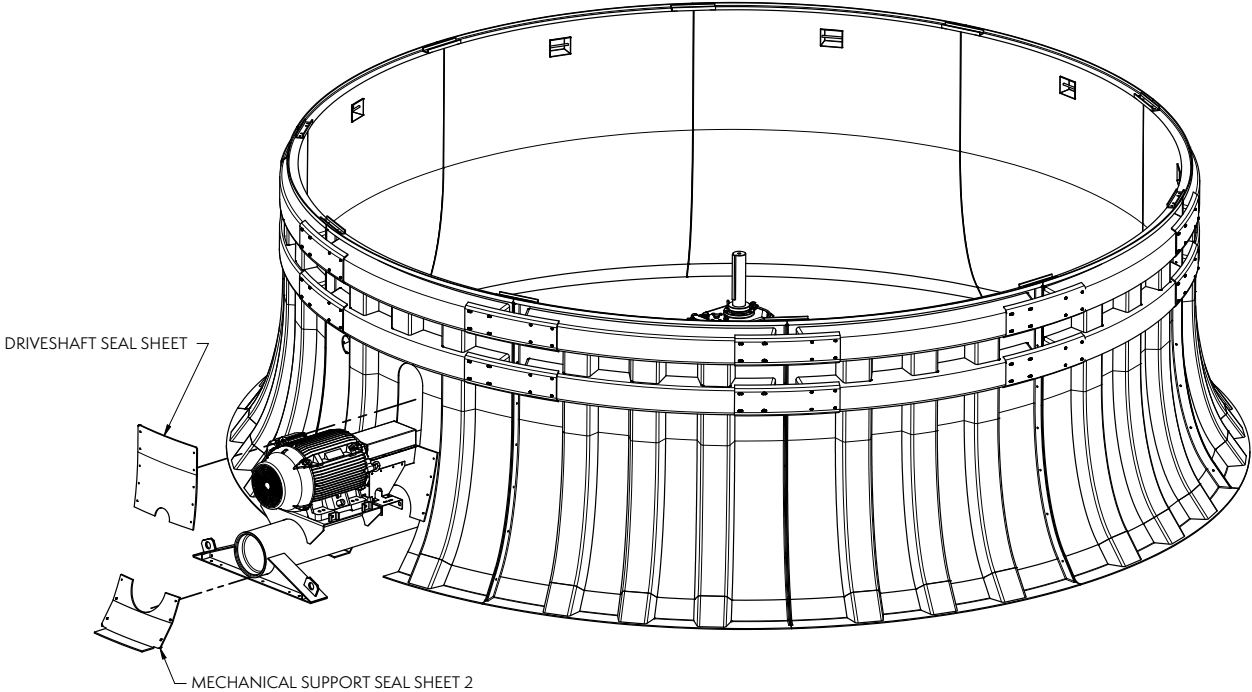

Figure 30 — Seal Sheet 2 and Driveshaft Seal Sheet Assembly

Fan Cylinder Sealing

After the fan cylinder is assembled and secured on the fan deck, caulk the seams of the cylinder. This is to be done from inside the unit. Caulk sealant must also be applied between the fan cylinder and the fan sections as well as around the torque tube.

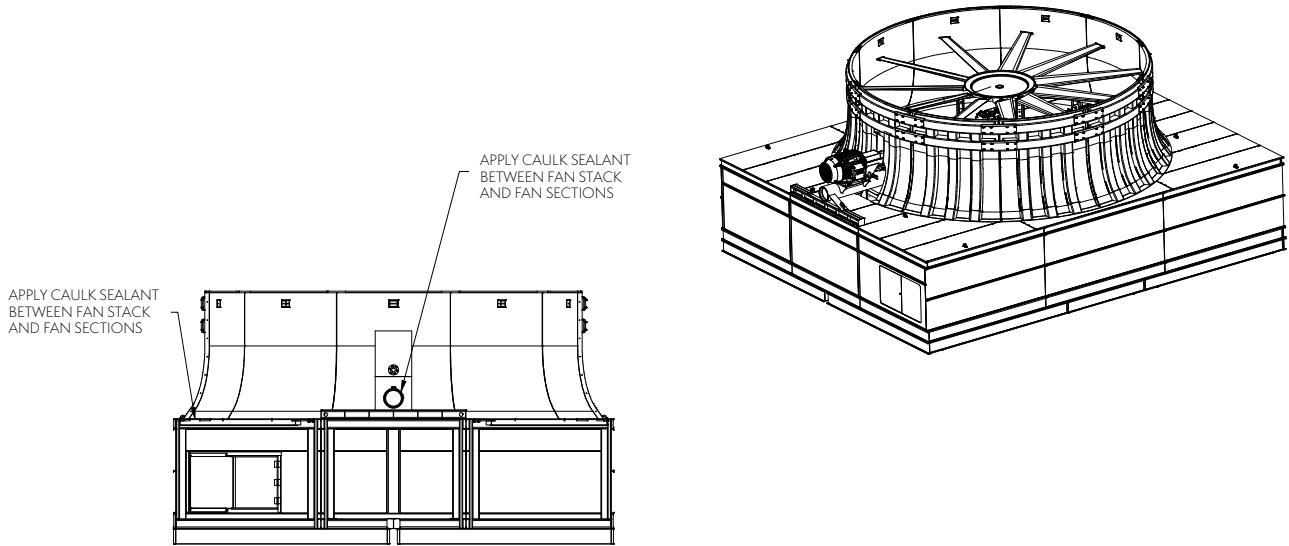

Figure 31a — Standard Fan Cylinder Sealing

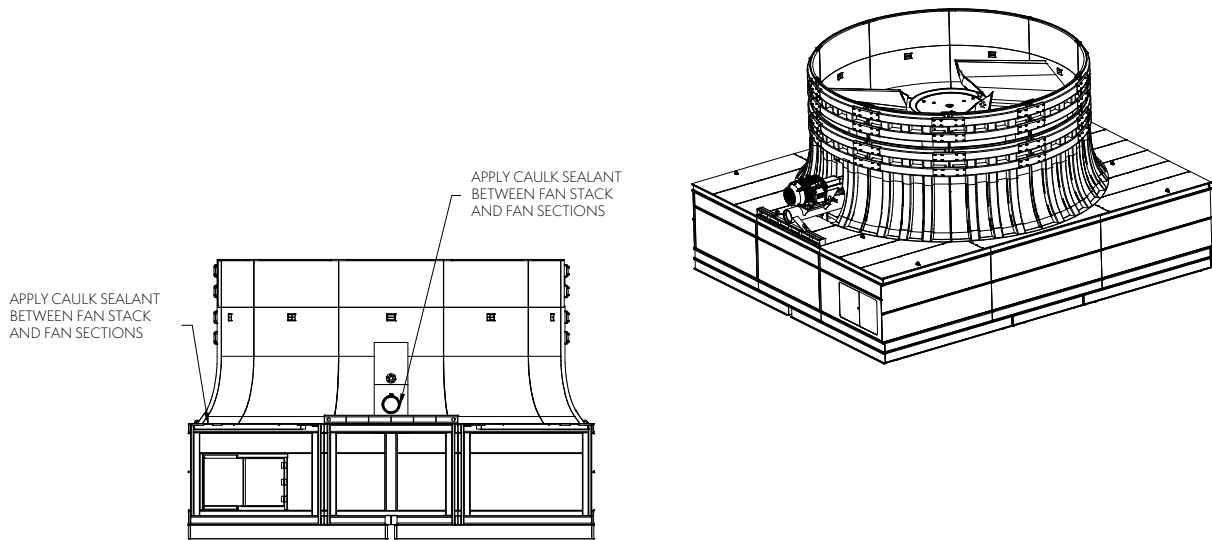

Figure 31b — Super Low Sound Fan Cylinder Sealing

Super Low Sound Fan Cylinder Diagonal Supports

After the fan cylinder is rigged, attach diagonal supports to diagonal support bracket and fan deck.

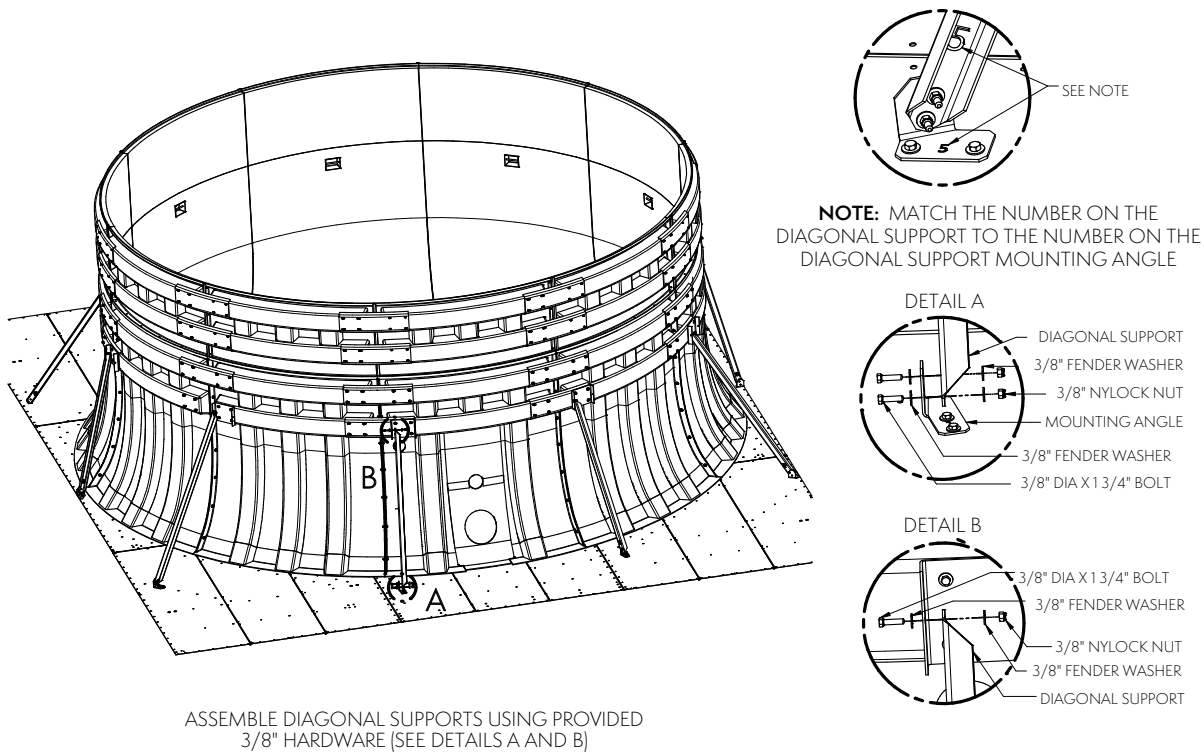

Figure 32 – Super Low Sound Fan Diagonal Supports

Installing Watertight Partitions & FM Partition Panels

In some cases, a multi-cell unit is ordered with watertight partitions to allow for independent cell operation. To correctly assemble the upper sections to the bottom sections, access to the rigging seams in between cells is necessary. To facilitate with this access, the watertight partition is shipped loose for installation in the field. **Figure 33** below provides instruction to install these in the field.

NOTE: The below instruction and arrangement also applies for Factory Mutual (FM) Approved multi-cell units, in which case these partitions will be referred to as FM Partition Panels.

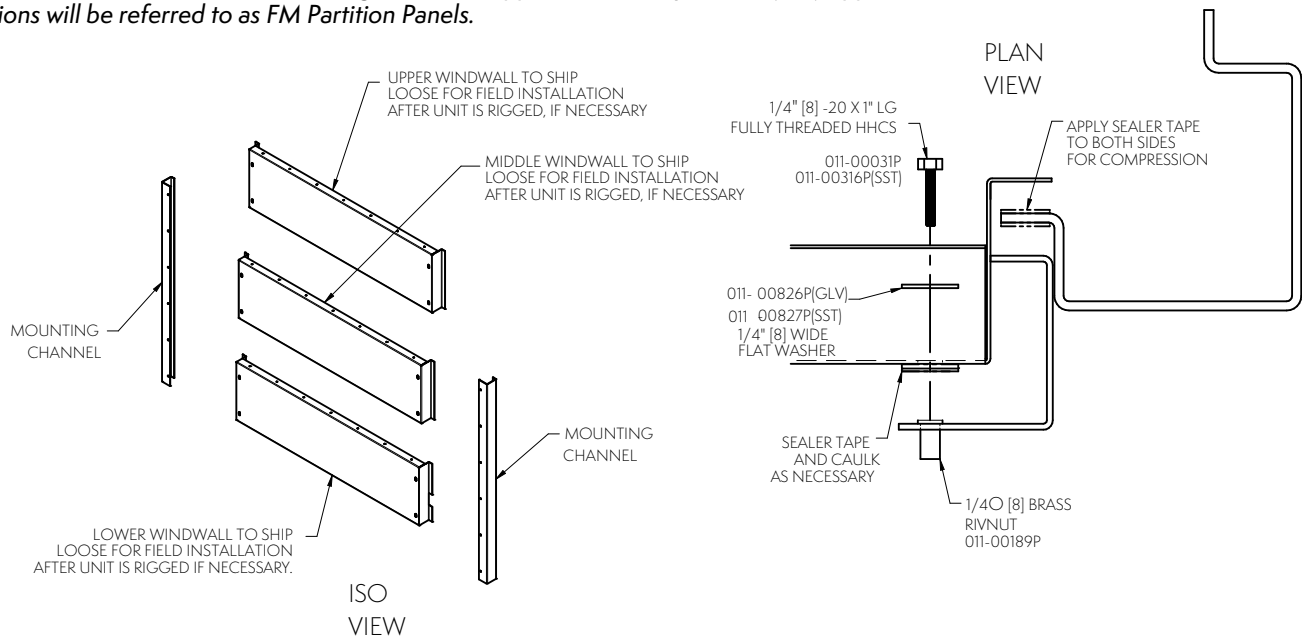

Figure 33 – Upper Partition/Firewall Installation in Field



External Platform and Vertical Ladder Installation

If your unit is accessorized with an external service platform assembly with a vertical ladder, this equipment is shipped in the basin of your unit. In some cases, they are shipped separately due to other basin accessories that may interfere with storage. The platform is partially assembled prior to shipment to minimize field assembly.

Typically, there is one working platform and ladder assembly per cell. Refer to your factory submittal for details.

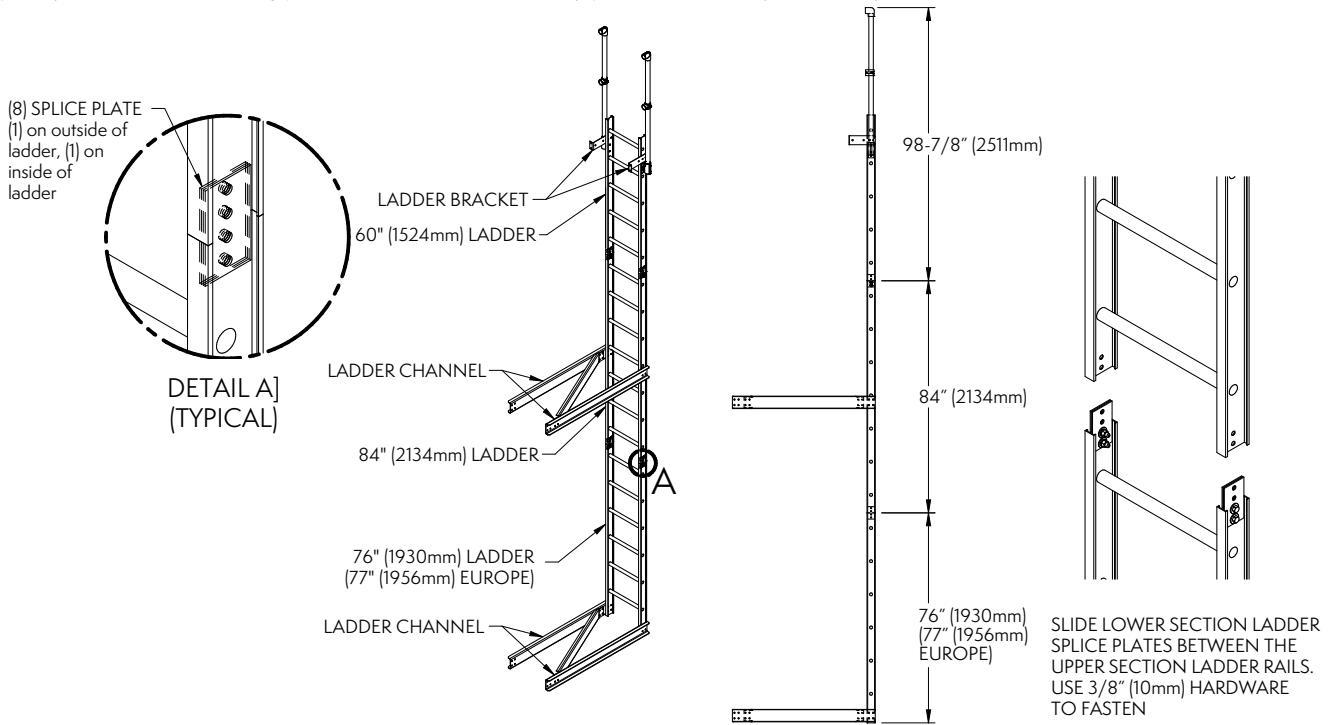
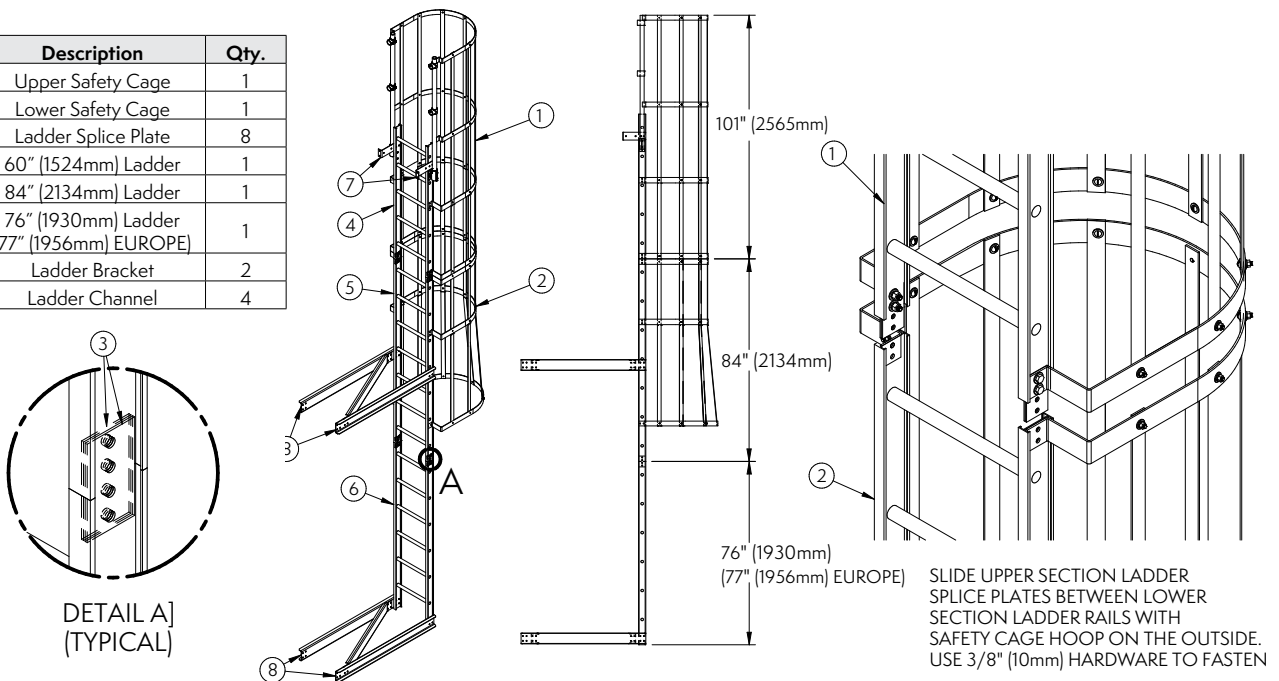

Figure 34 - Assembly of Vertical Ladder Accessory

Item	Description	Qty.
1	Upper Safety Cage	1
2	Lower Safety Cage	1
3	Ladder Splice Plate	8
4	60" (1524mm) Ladder	1
5	84" (2134mm) Ladder	1
6	76" (1930mm) Ladder (77" (1956mm) EUROPE)	1
7	Ladder Bracket	2
8	Ladder Channel	4



NOTE: Attach items as shown using 3/8" (10mm) hardware.

Figure 35 — Assembly of Vertical Ladder Accessory with Safety Cage

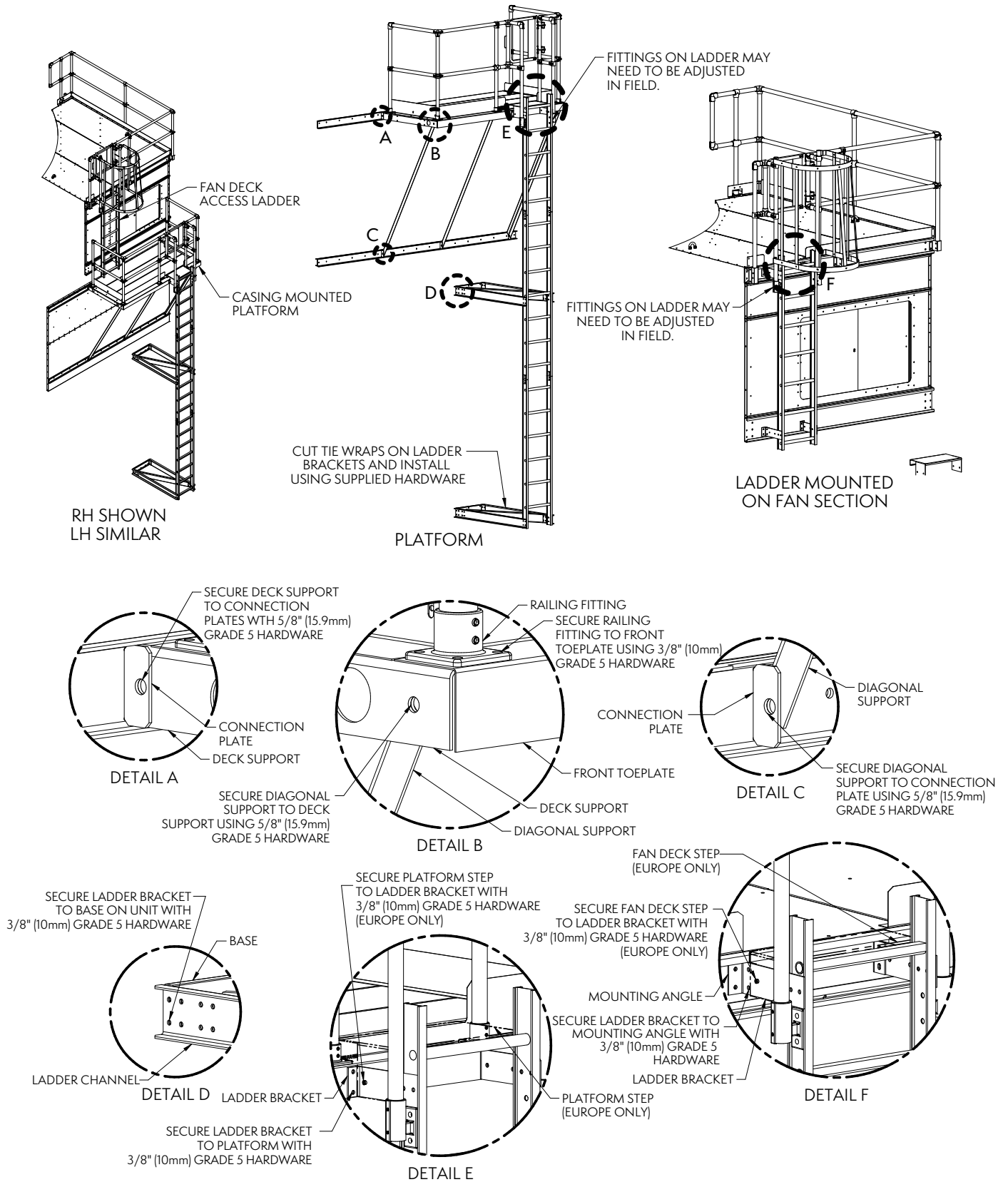

Figure 36 — Installing Vertical Ladder Accessory, with Details

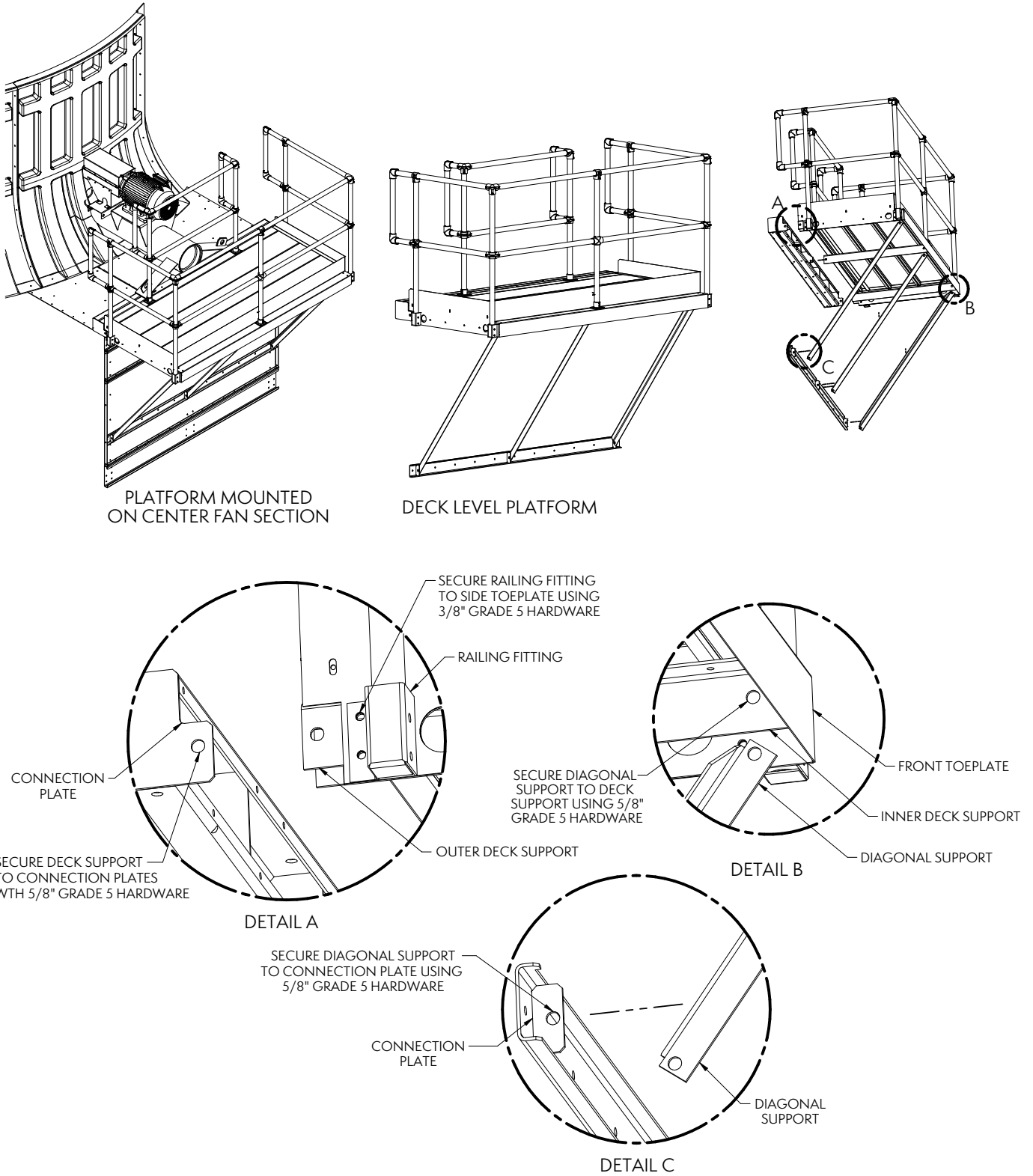
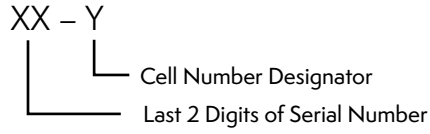

Figure 37 —Installing External Motor Walkaround Platform Accessory, with Details

NOTE: For any other accessories not shown in this manual, refer to job specific general arrangement drawings, located in rigging box or contact your EVAPCO representative.

Appendix A

Units are provided with match markings on each section. Standard match marking location is at the rigging seam on the motor end of the unit. Standard match marking designation is shown below:



Example:

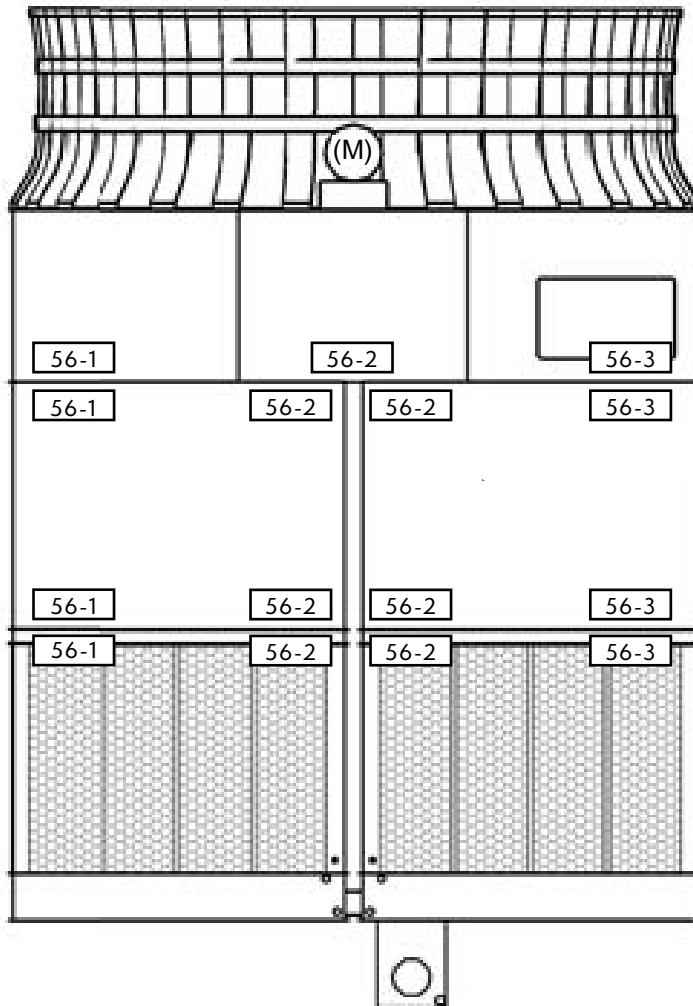
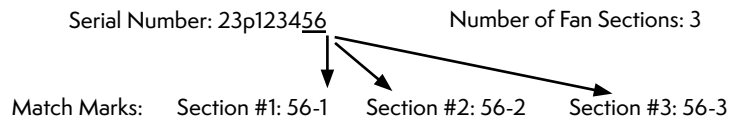



EVAPCO, Inc. • P.O. Box 1300 • Westminster, MD 21158 USA
Phone: 410.756.2600 • Fax: 410.756.6450 • E-mail: marketing@evapco.com

©2025 EVAPCO, Inc.



Printed on recycled paper
using soy-based ink