



# AT/UT/USS

COOLING TOWERS



Now INCLUDES  
**14' x 26'**  
Box Sizes



COMPLETE  
5 YEAR PRODUCT WARRANTY  
STANDARD ON STAINLESS  
STEEL MODELS



**ADVANCED TECHNOLOGY IN**  
INDUCED DRAFT, COUNTERFLOW COOLING TOWERS  
**33 to 5,141 NOMINAL TONS**  
**(144 TO 22,596kW)**



*TECHNOLOGY FOR THE FUTURE...AVAILABLE TODAY!*





# AT/UT/USS

EVAPCO, Inc., continues its dedication to advancements in induced draft, counterflow cooling tower technology and easy maintenance with the

Advanced Technology Cooling Tower...The EVAPCO AT!

The AT is the result of decades of engineering success based on easy maintenance, durable construction and a highly efficient design. The AT brings marquee features that make it the best choice in cooling towers.



Since its founding in 1976, EVAPCO, Incorporated has become an industry leader in the engineering and manufacturing of quality heat transfer products around the world. EVAPCO's mission is to provide first class service and quality products for the following markets:

- Industrial Refrigeration
- Commercial HVAC
- Industrial Process
- Power

EVAPCO's powerful combination of financial strength and technical expertise has established the company as a recognized manufacturer of market-leading products on a worldwide basis. EVAPCO is also recognized for the superior technology of their environmentally friendly product innovations in sound reduction and water management.

EVAPCO is an employee owned company with a strong emphasis on research & development and modern manufacturing plants. EVAPCO has earned a reputation for technological innovation and superior product quality by featuring products that are designed to offer these operating advantages:

- Higher System Efficiency
- Environmentally Friendly
- Lower Annual Operating Costs
- Reliable, Simple Operation and Maintenance

With an ongoing commitment to Research & Development programs, EVAPCO provides the most advanced products in the industry—**Technology for the Future, Available Today!**



EVAPCO products are manufactured in 19 locations in 9 countries around the world and supplied through a sales network consisting of over 170 offices.



### Totally Enclosed Fan Motors

- Motors positioned for easy accessibility and extended serviceability.
- Assures long life.
- Five (5) Year motor warranty.
- Energy efficient/inverter capable motors standard on all motors.
- Optional space heaters to eliminate condensation while idle.



### EVAPCO Power-Band Drive System

- The AT Cooling Tower features the highly successful, easy maintenance, heavy duty Power-Band Drive System.
- Standard heavy-duty pillow block bearings with a minimum L10 life of 75,000 hours.
- Extended lube lines.
- External motor/belt adjustment.
- Solid-Back Multi-Groove Power-Band Belts and Totally Enclosed motors are standard.
- Five (5) Year Motor and Drive Warranty.

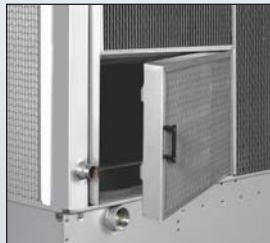

### Louver Access Door

- Hinged access panel with quick release mechanism.
- Allows easy access to perform routine maintenance and inspection of the makeup assembly, strainer screen and basin.
- Standard on models with louvers 5 ft. or taller.



### Easy Field Assembly

- A new field assembly seam design which ensures easier assembly and reduced potential for field seam leaks.
- Self-guided channels guide the fan casing section into position improving the quality of the field seam.
- Eliminates up to 66% of fasteners compared to old design.



### WST Air Inlet Louvers (Water and Sight Tight)

- Easily removable for access.
  - Framed in same material as tower basin.
  - Improved design to keep sunlight out—preventing biological growth.
  - Keeps water in while keeping dirt and debris out.
- U.S. Patent No. 7,927,196

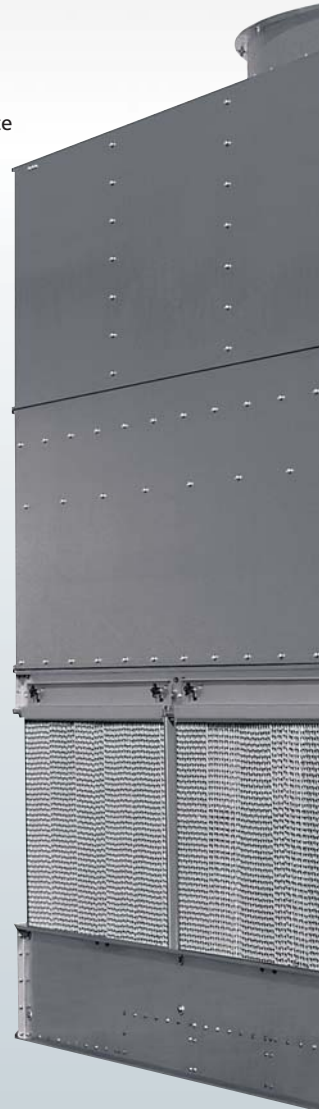



**Available in 60 Cross Sections and a capacity range of 33 to 5,141 Nominal Tons (144 to 22,596 kW)! The AT has a model for every application.**

If there is an application for which the standard catalog product line does not work, EVAPCO will make a cooling tower that will fit your requirement! Consult your local EVAPCO Representative or the factory for all your cooling tower needs.

### CTI Certified-Standard 201

- Independent Certification.
- Eliminates necessity for costly field performance tests.

### Optional Motor Davit and Working Platform

#### Motor Davit

- Motor davit and bracket option for easy motor removal.
- Also available for Gearbox removal.

#### Platform

- Platform and ladder arrangement available as an option.
- Provides a robust self-supporting working surface for the service mechanic.

### IBC and OSHPD Designs

- All standard models meet IBC requirements for  $\leq 1.0$  g seismic or 60 psf wind loads.
- Upgraded designs which meet up to 5.12 g seismic or 145 psf wind loads are available for all models.
- Upgraded designs can also be used for projects requiring OSHPD approval.
- See pages 60-61 for more information about IBC and OSHPD.

U.S. Patent Nos. 7,938,373 and 7,963,492

### Smooth Flow Fan

- Soft-connect blade to hub design.
  - Variable Frequency Drive friendly
  - Eliminates critical blade passing frequencies at any speed.
- (Not available on 4 ft. wide models)  
See page 5 for more information.

### Exclusive 5 Year Motor & Drive Warranty

- Covers the complete drive system, including the motor.
- Covers all drive components on belt or gear drive units.
- Standard on all AT Models.
- Upgraded 5 year Complete Product warranty on models with optional stainless steel construction.



### EVAPAK® Fill

- Induces highly turbulent mixing of the air and water for superior heat transfer.
- Special drainage tips allow high water loading without excessive pressure drop.
- Flame spread rating of 5 per ASTM E84-81a.
- Can be used as an internal working platform.



EvapJet™ Nozzle



### Water Distribution System

- Non-corrosive PVC construction with EvapJet™ nozzles.
- Large orifice nozzles prevent clogging and are threaded for easy removal and positive positioning.
- Each nozzle provides a large uniform spray pattern.
- System branches have threaded end caps to assist with debris removal.

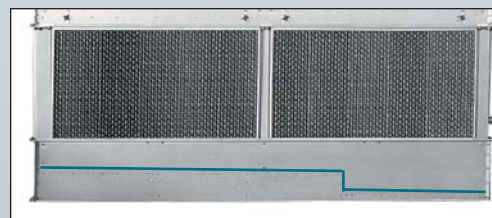

### Clean Pan Sloped Basin Design

- Designed to completely drain the cold water basin.
  - Helps prevent buildup of sediment and biological film.
  - Eliminates standing water after drain down.
- (See details of design on page 8)

### Quick Connect Piping System

- All inlet and outlet piping connections are beveled for welding and grooved to accept a mechanical coupling device as standard, except on 4 ft. wide models which have MPT connections.
- Facilitates easy pipe connections for quick installation.
- Flanged connections are available as an option. (See page 10 Optional Equipment)





# AT/UT/USS

## DESIGN ADVANTAGES

### The Advanced Technology Design

The AT Cooling Tower product line is an Advanced Technology design which utilizes induced draft, counterflow technology—the most efficient in the industry and the best design for operation in a freezing climate. The counterflow design provides the AT Cooling Tower with inherently better operational and maintenance features. These features are described below.

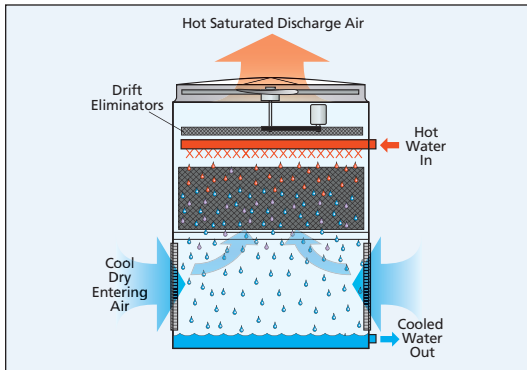

### Principle of Operation

Warm water from the heat source is pumped to the water distribution system at the top of the tower. The water is distributed over the wet deck fill by means of large orifice nozzles. Simultaneously, air is drawn in through the air inlet louvers at the base of the tower and travels upward through the wet deck fill opposite the water flow. A small portion of the water is evaporated which removes the heat from the remaining water. The warm moist air is drawn to the top of the cooling tower by the fan and discharged to the atmosphere. The cooled water drains to the basin at the bottom of the tower and is returned to the heat source. For detailed layout information please consult EVAPCO's Equipment Layout Guidelines Bulletin 311.

### Optimum Design for Freezing Climates

The counterflow fill design used in the AT Cooling Tower is well suited for operation in freezing climates. The wet deck fill is totally encased and protected from freezing winds thus inhibiting ice formation in the fill section. The bonded block structure and bottom supports eliminate fill collapse should ice form.

The even temperature gradient of the counterflow design ensures all water is cooled to the same temperature. This makes the AT Cooling Tower the ideal unit for operation in freezing climates.

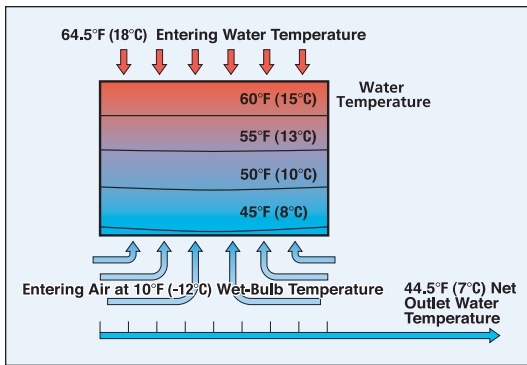

### EVAPAK® Fill\*

The EVAPAK® fill design used in the AT Cooling Tower is specially designed to induce highly turbulent mixing of the air and water for superior heat transfer. Special drainage tips allow high water loadings without excessive pressure drop. The fill constructed of inert polyvinyl chloride (PVC), will not rot or decay, and is formulated to withstand water temperatures of 130°F (55°C). Because of the unique way in which the crossfluted sheets are bonded together, and the bottom support of the fill section, the structural integrity of the fill is greatly enhanced, making the fill usable as a working platform for internal access to the fan and drive system. The fill selected for the AT Cooling Tower has excellent fire resistant qualities. AT Cooling Tower fill has a flame spread rating of 5 per ASTM-E84-81a.

A higher temperature fill is available for water temperatures exceeding 130°F (55°C). Consult your EVAPCO representative for further details.

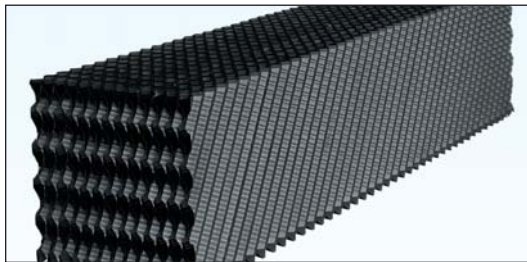

### Patented\*\* High Efficiency Drift Eliminators

An extremely efficient drift eliminator system is standard on the AT Cooling Towers. The system removes entrained water droplets from the air stream to limit the drift rate to less than 0.001% of the recirculating water rate. With a low drift rate, the AT Cooling Tower saves valuable water and can be located in areas where minimum water carryover is critical, such as parking lots.

The drift eliminators are constructed of an inert polyvinyl chloride (PVC) plastic material which effectively eliminates corrosion of these vital components. They are assembled in sections to facilitate easy removal for inspection of the water distribution system.



### Thermal Performance Guarantee

EVAPCO unequivocally guarantees the thermal performance of the AT Cooling Tower product line.

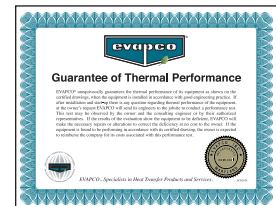

\* U.S. Patent No. 5,124,087  
\*\* U.S. Patent No. 6,315,804



## DESIGN ADVANTAGES

# AT/UT/USS

AT



### Smooth Flow Fans

The AT Cooling Tower has three fan options, standard, low sound and super low sound.

Standard fans for all units wider than 4' are axial propeller-type constructed of aluminum alloy. Standard fans for 4' wide units are also axial propeller type but have a high strength die cast aluminum hub and fiberglass reinforced polypropylene (PPG) wide chord blades. Each fan is statically balanced and installed in a closely fitted cowl with venturi air inlet for maximum efficiency. Fan screens are galvanized steel or optional Type 304 stainless steel and have steel frames bolted to the fan cowl.

See page 12 for more information on the low sound fan and Super Low Sound Fan options.



### Pressurized Water Distribution System

The water distribution system is made of schedule 40 PVC pipe and EvapJet™ ABS plastic water diffusers for corrosion protection in this key area. The piping is easily removable for cleaning. The wide orifice

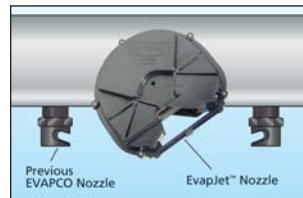

EvapJet™ nozzle compared to previous EVAPCO nozzles

nozzles mounted on the side of the pipe used in the AT water distribution system help prevent clogging, reducing the maintenance costs of the water distribution system.

The spray pressure for all AT Cooling Towers is between 1 and 6 psig (7 and 41 kPa) at the inlet header. The actual spray pressure will be shown on the submittal which is prepared for each unit.

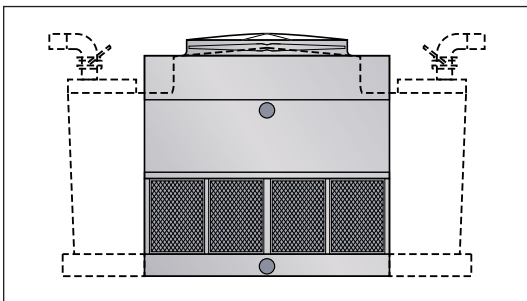

### Reduced Piping Costs

Each cell of the AT Cooling Tower is furnished with one inlet and one outlet piping connection. This design reduces the amount of external piping and thereby lowers the installed cost of the cooling tower relative to crossflow cooling towers. The water distribution system is pressurized and self balancing. On single cell installations, field balancing is not required on the AT, and the need for flow balancing valves is eliminated, further reducing the cost of tower installation.

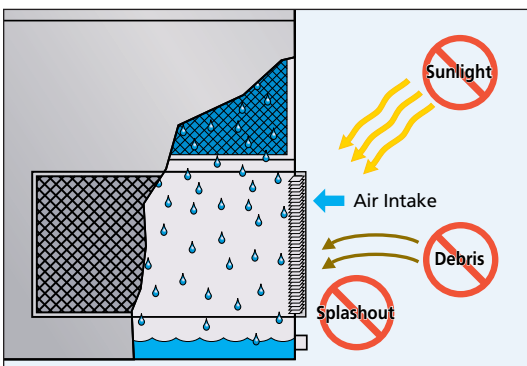

### Superior Air Inlet Louver and Screen Design\*\*\*

EVAPCO'S WST Inlet Louvers keep water in and sunlight out of induced draft products. The unique non-planar design is made from light-weight framed PVC sections which have no loose hardware, enabling easy unit access.

Developed with computational fluid dynamics (CFD) software, the louver's air channels are optimized to maintain fluid dynamic and thermodynamic efficiency and block all line-of-sight paths into the basin eliminating splash-out; even when the fans are off. Additionally, algae growth is minimized by blocking all sunlight.

The combination of easy access, no splash-out and minimized algae growth saves the end user money on maintenance hours, water consumption and water treatment costs.

\*\*\* U.S. Patent No. 7,927,196



# AT/UT/USS

## DESIGN ADVANTAGES

### The Advanced Technology POWER-BAND Design Advantages

The AT Cooling Tower features the highly successful EVAPCO POWER-BAND Belt Drive System engineered for heavy-duty operation. The POWER-BAND Drive System has consistently provided trouble-free operation in the most severe duty cooling tower applications. In addition, the complete drive system including the fan motor is standard with a (5) Five Year Motor & Drive Warranty.



#### Fan Motors

All AT Cooling Tower models utilize premium efficiency, inverter capable totally enclosed (T.E.F.C. or T.E.A.O.) fan motors designed specifically for cooling tower applications. In addition to the standard motors offered on each cooling tower, EVAPCO offers options to meet your specific needs, including:

- Multi-Speed Motors
- Space Heaters
- Thermistors
- Shaft Grounding Rings



#### Power-Band Belt Drive

The Power-Band drive is a solid-back multigroove belt system that has high lateral rigidity. The belt is designed for cooling tower service, and is constructed of neoprene with polyester cords. The drive belt is sized for 150 percent of the motor nameplate horsepower ensuring long and trouble free operation.

#### Drive System Sheaves

Drive system sheaves located in the warm, moist atmosphere inside the cooling tower are constructed of an aluminum alloy. Models with T.E.F.C. motors have a steel driver sheave protected by a hinged cover.

#### Fan Shaft Bearings

The fan shaft bearings on the AT cooling tower are specially selected to provide long life, minimizing costly downtime. They are rated for a minimum L-10 life of 75,000 hours, making them the heaviest duty pillow block bearing in the industry used for cooling tower duty.



#### Five Year Motor and Drive Warranty

EVAPCO provides a standard 5 year motor and drive warranty on all Power-Band belt drive and optional gear drive AT Cooling Towers. This unique warranty is designed to offer the end user optimum protection against fan drive and motor failure. It is a comprehensive plan which includes the fan, fan shaft, belts, sheaves, fan bearings, gear box, flexible coupling, driveshaft and the motor.



#### Fast, On-Time Shipments

The AT is a completely factory assembled cooling tower manufactured by a dedicated professional workforce, expert in building cooling towers. Factory trained mechanics and EVAPCO's strict quality control and inspection procedures guarantee the quality of every unit shipped.

EVAPCO's controlled factory environment ensures fast on-time shipments, allowing the AT to be available...

**WHEN THE CUSTOMER WANTS IT!**



## MAINTENANCE ADVANTAGES

# AT/UT/USS

AT

### The Advanced Technology Easy Maintenance Drive System

The EVAPCO POWER-BAND drive system utilized on the AT Cooling Tower is the *easiest* drive system to maintain in the industry. There is no need to stand inside the cold water basin to service the bearings, belts, gear reducers, floating shafts or electrical equipment. In addition, there is no need for fan deck handrails or safety cages, since all periodic maintenance can be safely performed from the side of the unit. The most important features of this design are listed below.

#### Motor Mount, Power-Band Belt Adjustment and Bearing Lubrication Individual Cells 4' wide to 8.5' wide

The fan motor and drive assembly are designed to allow easy servicing of the motor and adjustment of the belt tension from the exterior of the unit. The Totally Enclosed Fan Cooled, T.E.F.C. fan motor is mounted on the outside on these models and is protected from the weather by a cover which swings away for maintenance.

A large hinged access door is located on the side of the unit for easy access to the fan drive system. The belt can be adjusted by tightening the J-Bolts on the motor base and the tension can be checked easily through the access door, all while standing



at the side of the unit. The bearings can also be lubricated from the side of the unit. The bearing lubrication lines have been extended to the exterior casing and are located by the access door, thus making bearing lubrication easy.

*Sloped maintenance ladders and working platforms are available as an option to facilitate maintenance. See page 9, Optional Equipment, for details.*



#### Individual Cells wider than 8.5'



The Totally Enclosed Air Over, T.E.A.O. fan motor is located inside the fan casing on the large AT Cooling Tower and is mounted on a rugged heavy duty motor base. The motor base is designed to swing completely to the outside of the unit through a very large hinged (14 square feet) (1.3 square meters) access door greatly simplifying motor maintenance.

The unique swinging motor mount designed for these models features easy belt adjustment from the exterior of the unit. The T.E.A.O. fan motor is mounted on an adjustable base which is supported by two heavy duty pipes. The belt is adjusted by tightening an all-thread which runs through the motor base.

The innovative motor base features a unique locking mechanism for a positive belt adjustment and is also used to adjust the belt tension if a wrench is not available.

Bearing lubrication fittings are extended to the side of the unit inside the access door to allow easy application of the bearing lubricant. This external location allows for easy servicing of the bearings and is another important advantage of EVAPCO equipment.

*To facilitate motor removal, an optional motor davit is available. See Optional Equipment on page 9 of this brochure.*



# AT/UT/USS

## MAINTENANCE ADVANTAGES

### The Advanced Technology Easy Maintenance Basin Design

The cold water basin is the most important area of a cooling tower to maintain. As a result of the evaporation process and the direct contact of the water with air in a cooling tower, dirt and debris will collect in the basin and must be cleaned out on a regular basis. EVAPCO's AT basin section is designed to allow quick and easy access—promoting routine maintenance of the cold water basin. The basin features the following:



#### Easy Access

The cold water basin section is easily accessible from ground level by simply loosening the (2) two Quick Release Fasteners on the inlet louver assemblies surrounding the cooling tower and lifting out the lightweight louver.

The basin can be accessed from all (4) four sides of the cooling tower. The bottom of the fill section is a minimum of four (4) feet (1.2m) above the basin floor. This open basin design enables the AT basin to be easily cleaned. The 4' wide models are accessible on only two sides.

#### Louver Access Door

To aid in basin maintenance, most AT models can be equipped with an optional louver access door. This feature allows easy access to perform routine maintenance and inspection of the makeup assembly, strainer screen and basin without removing an entire inlet louver. This feature is standard on models with louvers 5' or taller and optional on models with 4' tall louvers.

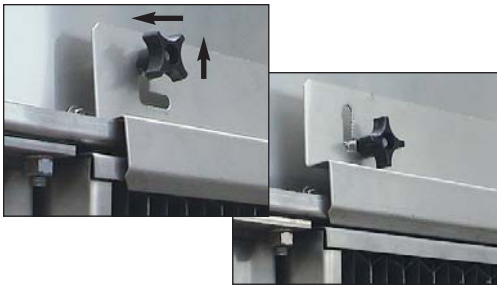

#### Easy, Removable Air Inlet Louvers with Quick Release Fasteners

The AT features a Quick Release Fastener design consisting of (2) two large thumbscrews and a retaining bracket system. By loosening the thumbscrews, the retaining bracket lifts away from the louver frame, allowing the louver to be removed while the retaining bracket and thumbscrews stay on the cooling tower.

- Design allows quick removal of louvers.
- Louver fastener is large and easy to release.
- Louver fastener remains on the unit—eliminating the possibility of missing hardware.

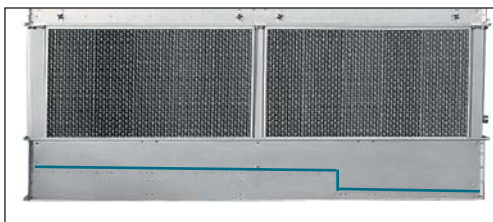

#### Clean Pan Basin Design

The AT features a completely sloped basin from the upper to lower pan section. This "Clean Pan" design allows the water to be completely drained from the basin. The cooling tower water will drain from the upper section to the depressed lower pan section where the dirt and debris can be easily flushed out through the drain. This design helps prevent buildup of sedimentary deposits, biological films and minimizes standing water.

Note: on 4' wide units, the pan is sloped without the step



#### Stainless Steel Strainers

The EVAPCO standard for many years, the stainless steel strainer is one component of the cooling tower subject to excessive wear and corrosion. With the standard stainless steel construction, this component will last the life of the cooling tower.



## OPTIONAL EQUIPMENT

# AT/UT/USS

AT

### Optional Equipment

The standard design of the EVAPCO AT provides the customer with the *easiest* cooling tower to maintain in the industry. There are additional options which can make maintenance easier and extend the life of the cooling tower. These options are listed below.



#### Sloped Maintenance Ladders

The EVAPCO designed maintenance ladder features a sloped "ships type" ladder which provides visual inspection of the water distribution system and drive components. All standard drive system maintenance can be performed from the ladder. A handrail is attached to the sloped ladder for safe and easy ascent and descent. There is no need for safety cages with this design. The ladder will ship loose and must be field mounted. The design is OSHA compliant.

*Note: The sloped maintenance ladder is available on all models wider than 4'. A vertical ladder is available on all 4' wide models.*



#### Working Platform & Ladder with Davit

AT Cooling Towers are available with an external working platform and ladder to allow easy servicing of the fan motor and water distribution system. Providing a convenient platform to perform work, the heavy duty galvanized steel platform is self-supporting. A less expensive alternative to field erected catwalks, the working platform option uses a straight ladder as standard and ships in sections for easy installation. The working platform and ladder designs are OSHA compliant.

*Note: The Working Platform is not available on 4 ft. wide models.*

The optional davit eliminates crane rentals and facilitates the removal of motors, gear drives and fans. The davit is constructed of aluminum. The galvanized steel bracket is mounted on the side of the unit. The davit ships loose and is installed in the field.

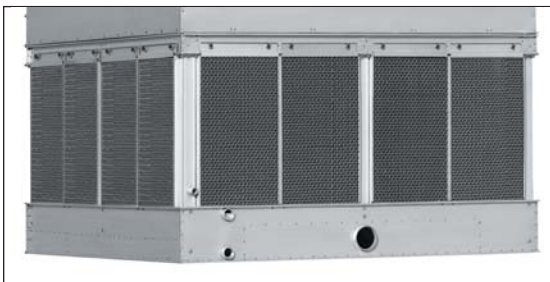

#### Stainless Steel Water Touch Basin

The AT Cooling Tower has a modular design which allows specific areas to be enhanced for increased corrosion protection. The basin area of the cooling tower experiences turbulent mixing of air and water, in addition to silt build-up. This option provides Type 304 or Type 316 stainless steel for the entire basin area including the support columns and plenum of the cooling tower and the louver frames.

The basin section provides the structural support for the unit and is the most important part of the cooling tower. The Stainless Steel Water Touch Basin provides maximum corrosion protection.



#### Basin Level Platform

A basin level platform and ladder to allow easy servicing of the cold water basin is available on some box sizes. For cooling towers above ground level the basin level platform facilitates standard inspections and maintenance, such as float assembly adjustment and basin and suction strainer cleaning. The platform is supported from the unit, but the ladder requires field support. The platform and ladder ship in modules for easy installation.

# AT/UT/USS

## OPTIONAL EQUIPMENT

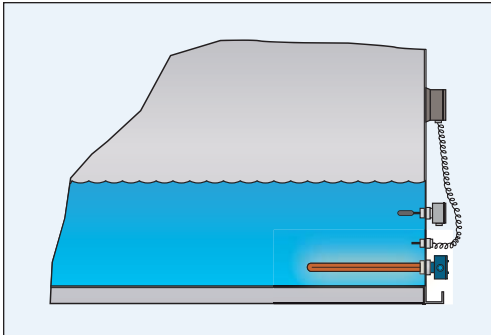

### Electric Heaters

Electric immersion heaters are available as an option and are located in the basin of the tower. They are sized to maintain a +40° F (4.5°C) pan water temperature with the fans and system pumps off\*. They are furnished with a thermostat and low water protection device to cycle the heater on when required and to prevent the heater elements from energizing unless they are completely submerged. All components are enclosed in rugged, weather proof enclosures for outdoor use. Heater control packages that include contactor, transformer or disconnects are available, consult your local EVAPCO representative.

\* See page 11 for heater size information.



### Electronic Water Level Control (EWLC)

EVAPCO cooling towers are available with an optional electronic water level control system in place of the standard mechanical makeup and float assembly. This package provides very accurate control for the basin water level and does not require field adjustment, even under varying operating conditions.

The controls were designed by EVAPCO and are manufactured exclusively for EVAPCO. They consist of multiple heavy duty stainless steel electrodes. These electrodes are mounted on the outside of the unit in a vertical stand pipe which acts as a stilling chamber. For winter operation, the stand pipe must be wrapped with electric heating cable and insulated to protect it from freezing. Electronic water level control packages are available with 3 or 5 probes. The 5 probe package provides high and low level alarms.

The weather protected slow closing solenoid valve for the makeup water connection is factory supplied and is ready for piping to a water supply with a pressure between 5 and 125 psig (34 and 862 kPa).



Flanged Connections



Bypass Connections with Diffuser Hood



Equalizers and Flume Plates

### Other Options

- Vibration Switches
- Sump Sweeper Piping
- FM Approval
- Alternate Fills for dirty water/environment applications
- Bottom Inlet and Bottom Suction Connections
- Remote Sump Connections (see page 66 for more information)
- Materials for Higher Temperature Applications
- Titan-Pak Stainless Steel Fill

## Technical Support Services

### evapSelect®

evapSelect® is a computer selection program which allows the design engineer to choose EVAPCO models and optimize unit selections. The program allows the engineer to evaluate the equipment's thermal performance, space and energy requirements. Once the model is selected and optional equipment features are inserted, the engineer may generate a complete specification **AND** a unit drawing from this program. The software is designed to provide the user with maximum flexibility in analyzing the various selection parameters while in a friendly and familiar Windows format.

The evapSelect® software program may be accessed after contacting your local EVAPCO sales representative. Users may make Requests for Quotations through the website or by e-mailing EVAPCO at this address [marketing@evapco.com](mailto:marketing@evapco.com)

### EVAPCO's Website

Log on to EVAPCO's website <http://www.evapco.com> for expanded product information. The website contains a multitude of information and resources including the following:

- Unit certified drawings (.pdf format)
- Steel support drawings (.pdf format)
- Scaled isometric views of towers in CAD (.dwg format)
- 3-D models of towers in Revit (.rfa format)
- Product literature
  - Catalogs
  - Rigging instructions
  - Operation and Maintenance Instructions
  - Videos
- Logo apparel and merchandise.

*With evapSelect®, equipment selections, written specifications, unit drawing files and EVAPCO on-line information are readily available from the comfort of your own office!*



# AT/UT/USS

AT

## ELECTRIC BASIN HEATER SIZES

### Electric Basin Heaters

Electric immersion heaters are available factory-installed in the basin of the towers. Standard Heaters are sized to maintain a +40°F pan water temperature with the fans off and an ambient air temperature of 0°F, -20°F or -40°F. The heater option includes a thermostat and low-water protection device to control the heater and to prevent it from energizing unless they are completely submerged. All components are in weather proof enclosures for outdoor use. The heater power contactors and electric wiring are not included as standard.

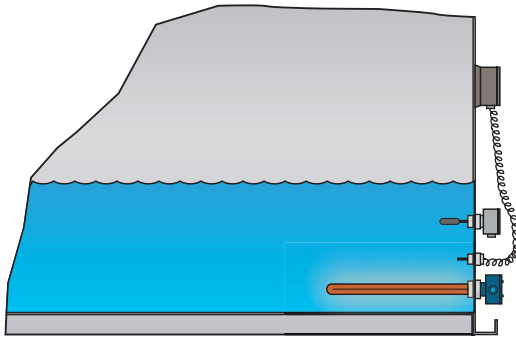

AT Heater Sizes \*

	Model No.	0°F kW	-20°F kW	-40°F kW
1-CELL	14-64 to 14-94	2	3	4
	14-66 to 14-96	3	4	5
	14-69 to 14-99	4	5	7
	14-612 to 14-912	5	7	9
	19-56 to 19-96	5	7	9
	19-28 to 19-98	6	8	12
	19-59 to 19-99	7	10	15
	19-111 to 19-911	8	12	15
	19-412 to 19-912	(2) 4	(2) 7	(2) 9
	19-114 to 19-914	(2) 5	(2) 7	(2) 10
	110-112 to 110-912	(2) 5	(2) 8	(2) 10
	110-118 to 110-918	(2) 7	(2) 12	(2) 15
	112-012 to 112-912	(2) 6	(2) 9	(2) 12
	112-314 to 112-914	(2) 7	(2) 10	(2) 15
	112-018 to 112-918	(2) 9	(2) 15	(2) 18
	112-520 to 112-920	(2) 10	(2) 15	(2) 15
	114-0124 to 114-1324	(2) 16	(3) 16	(3) 20
	114-526 to 114-926	(2) 16	(3) 16	(3) 20

AT Heater Sizes \*

	Model No.	0°F kW	-20°F kW	-40°F kW
2-CELL	26-517 to 26-917	(2) 5	(2) 7	(2) 9
	28-217 to 28-917	(2) 6	(2) 8	(2) 12
	29-318 to 29-918	(2) 6	(2) 9	(2) 12
	29-121 to 29-921	(2) 7	(2) 12	(2) 15
	29-024 to 29-924	(4) 4	(4) 7	(4) 9
	29-228 to 29-928	(4) 5	(4) 7	(4) 10
	210-124 to 210-924	(4) 5	(4) 8	(4) 10
	210-136 to 210-936	(4) 7	(4) 12	(4) 15
	212-59 to 212-99	(2) 5	(2) 7	(2) 9
	212-024 to 212-924	(4) 6	(4) 9	(4) 12
	212-128 to 212-928	(4) 7	(4) 10	(4) 15
	212-036 to 212-936	(2) 9	(2) 15	(2) 18
	214-0148 to 214-1248	(4) 16	(6) 16	(6) 20
	214-552 to 214-952	(4) 16	(6) 16	(6) 20
	215-29 to 215-99	(2) 6	(2) 8	(2) 12
	217-59 to 217-99	(2) 7	(2) 10	(2) 15
	217-111 to 217-911	(2) 8	(2) 12	(2) 15
	217-412 to 217-912	(4) 4	(4) 7	(4) 9
	217-214 to 217-914	(4) 5	(4) 7	(4) 10
	220-112 to 220-912	(4) 5	(4) 8	(4) 10
220-118 to 220-918	(4) 7	(4) 12	(4) 15	
224-018 to 224-918	(4) 9	(4) 15	(4) 18	
224-720 to 224-920	(4) 10	(4) 15	(4) 20	
228-0124 to 228-1024	(4) 16	(6) 16	(6) 20	
228-526 to 228-926	(4) 16	(6) 16	(6) 20	
3-CELL	39-336 to 39-936	(6) 4	(6) 7	(6) 9
	39-242 to 39-942	(6) 5	(6) 7	(6) 10
	310-136 to 310-936	(6) 5	(6) 8	(6) 10
	310-154 to 310-954	(6) 7	(6) 12	(6) 15
	312-036 to 312-936	(6) 6	(6) 9	(6) 12
	312-042 to 312-942	(6) 7	(6) 10	(6) 15
	312-054 to 312-954	(6) 9	(6) 15	(6) 18
	312-260 to 312-960	(6) 10	(6) 15	(6) 15
	314-0172 to 314-1272	(6) 16	(9) 16	(9) 20
	314-578 to 314-978	(6) 16	(9) 16	(9) 20
342-526 to 342-926	(6) 16	(9) 16	(9) 20	
4-CELL	420-124 to 420-924	(4) 10	(4) 15	(4) 20
	420-136 to 420-936	(4) 15	(4) 15	(4) 20
	424-024 to 424-924	(4) 12	(4) 18	(6) 15
	424-028 to 424-928	(4) 15	(4) 20	(6) 18
	424-036 to 424-936	(4) 18	(6) 18	(8) 18
	428-0148 to 428-1348	(8) 16	(8) 16	(8) 20
	428-552 to 428-952	(8) 16	(12) 16	(12) 20
	456-526 to 456-926	(8) 16	(12) 16	(12) 20

\* Electric heater selection based on ambient air temperature shown.

# AT/UT/USS

## LOW SOUND SOLUTIONS

### The Expanded Family of the EVAPCO Super Low Sound Fans!

For more information see Sound Basics on pages 19-21.



#### Super Low Sound Fan 9 – 15 dB(A) Reduction!

The Super Low Sound Fan offered by EVAPCO utilizes an extremely wide chord blade design for sound sensitive applications where the lowest sound levels are desired. The fan is two-piece molded heavy duty FRP construction utilizing a forward swept blade design. The Super Low Sound fan is capable of reducing the unit sound pressure levels **9 dB(A) to 15 dB(A)**, depending on specific unit selection and measurement location compared to the original AT fan. The Super Low Sound Fan will have no impact on unit thermal performance and is **CTI certified**.

*A Cooling Tower with a Super Low Sound Fan is designated as an UT, unless it is constructed of stainless steel in which case it is designated as an USS*

**Note:** The Super Low Sound Fan is not available on 4 ft wide models.



#### Low Sound Fan\* 4 – 7 dB(A) Reduction!

The Low Sound Fan offered by EVAPCO is a wide chord blade design for sound sensitive applications where low sound levels are desired. The Low Sound Fan shall utilize a unique soft-connect blade-to-hub design that is compatible with Variable Speed Drives. Since the blades are not rigidly connected to the fan hub, no vertical vibration forces are transmitted to the unit structure which reduces sound pressure levels **4 dB(A) to 7 dB(A)**, depending on specific unit selection and measurement location. The fans are high efficiency axial propeller type and are CTI Certified on the AT line of Cooling Towers.

See page 13 for low sound height and operating weight additions.

*The Low Sound Fan is NOT available on the UT Cooling Tower.*

\* *The CTI Certified Low Sound Fan will have a thermal performance derate up to 3.5%. Consult the factory or evapSelect® Program for actual thermal performance.*

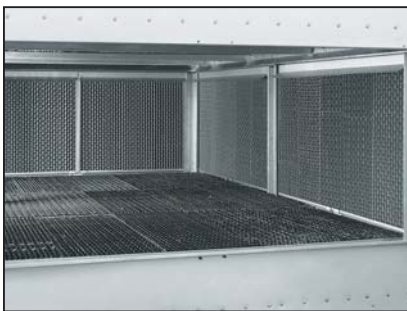

#### Water Silencer—Reduces Water Noise in the Cold Water Basin up to 7 dB(A)!

The water silencer option is available for all induced draft models and is located in the falling water area of the cold water basin. The water silencer will reduce the high frequency noise associated with the falling water and is capable of reducing overall sound levels **4 dB(A) to 7 dB(A)** measured at 5 ft. from the side or end of the unit. The water silencers reduce overall sound levels **9 dB(A) to 12 dB(A)** (depending on water loading and louver height) measured 5 ft. from the side or end of the unit when water is circulated with fans off.

The water silencers are constructed of lightweight PVC sections and can be easily removed for access to the basin area. *The water silencer will have no impact on unit thermal performance.*

*The Water Silencer is available on AT, USS and UT Cooling Towers.*

**Note:** Water Silencers are not available on 4 ft. wide models.





AT

# LOW SOUND FAN ADDITIONAL HEIGHT & OPERATING WEIGHT ADDITIONS

## Low Sound Fan

The Low Sound Fan offered by EVAPCO is a wide chord blade design for sound sensitive applications where low sound level is desired. This fan reduces sound pressure levels 4 db(a) to 7 db(A).

The following table provides the height and operating weight additions that need to be considered when a Low Sound Fan is selected.

**Note:** For similar information to the addition of the Super Low Sound Fan, please see the dimensional data table for each model.

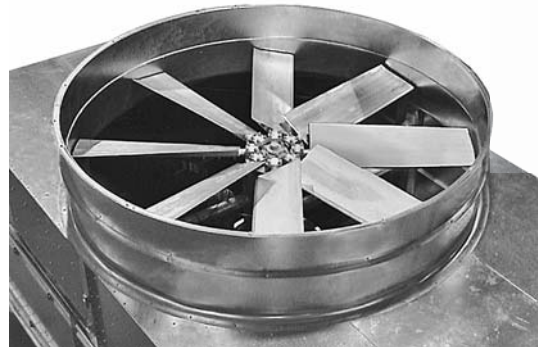

	Model No.	Height Addition for Low Sound Fan (in.)	Operating Weight Addition for Low Sound Fan (lbs.)
1 - CELL	14-64 to 14-94	0	0
	14-66 to 14-96	0	0
	14-69 to 14-99	0	0
	14-612 to 14-912	0	0
	19-56 to 19-96	4	0
	19-28 to 19-98	4	0
	19-59 to 19-99	4	0
	19-111 to 19-911	4	0
	19-412 to 19-912	4	0
	19-114 to 19-914	4	0
	110-112 to 110-912	0	0
	110-118 to 110-918	0	0
	112-012 to 112-912	0	0
	112-314 to 112-914	0	0
	112-018 to 112-918	7	225
	112-520 to 112-920	7	225
114-0124 to 114-1324	5	450	
114-526 to 114-926	7	450	
2 - CELL	26-517 to 26-917	4	0
	28-217 to 28-917	4	0
	29-318 to 29-918	4	0
	29-121 to 29-921	4	0
	29-024 to 29-924	4	0
	29-228 to 29-928	4	0
	210-124 to 210-924	0	0
	210-136 to 210-936	0	0
	212-59 to 212-99	4	0
	212-024 to 212-924	0	0
	212-128 to 212-928	0	0
	212-036 to 212-936	7	450
	214-0148 to 214-1248	5	900
	214-552 to 214-952	7	900

	Model No.	Height Addition for Low Sound Fan (in.)	Operating Weight Addition for Low Sound Fan (lbs.)
2 - CELL	215-29 to 215-99	4	0
	217-59 to 217-99	4	0
	217-111 to 217-911	4	0
	217-412 to 217-912	4	0
	217-214 to 217-914	4	0
	220-112 to 220-912	0	0
	220-118 to 220-918	0	0
	224-018 to 224-918	7	450
	224-720 to 224-920	7	450
	228-0124 to 228-1024	5	900
228-526 to 228-926	7	900	
3 - CELL	39-336 to 39-936	4	0
	39-242 to 39-942	4	0
	310-136 to 310-936	0	0
	310-154 to 310-954	0	0
	312-036 to 312-936	0	0
	312-042 to 312-942	0	0
	312-054 to 312-954	7	675
	312-260 to 312-960	7	675
4 - CELL	314-0172 to 314-1272	5	1350
	314-578 to 314-978	7	1350
	342-526 to 342-926	7	1350
	420-124 to 420-924	0	0
	420-136 to 420-936	0	0
4 - CELL	424-024 to 424-924	0	0
	424-028 to 424-928	0	0
	424-036 to 424-936	7	900
	428-0148 to 428-1348	5	1800
	428-552 to 428-952	7	1800
	456-526 to 456-926	7	1800

# AT/UT/USS

## IBC—INTERNATIONAL BUILDING CODE

### IBC - International Building Code

The International Building Code (IBC) is a comprehensive set of regulations addressing both the structural design and the installation requirements for building systems – including HVAC and industrial refrigeration equipment. All state and local jurisdictions have adopted the IBC or revised their local codes to mimic verbatim the IBC, including California's Building Code (CBC).

- Provisions in the IBC require that evaporative cooling equipment attached to a building must be designed to withstand the same seismic and wind loads as the building.
- When the equipment is attached to a critical facility, its ability to withstand the seismic load must be independently certified by a professional approval agency.

### Structural Design Selection

EVAPCO applies the seismic design and wind load information provided for the project to determine the equipment design necessary to meet IBC requirements. Based on the project zip code and site design factors, calculations are made to determine the equivalent seismic "g force" and wind load (in pounds per square foot, psf) on the unit. **Whichever design force – seismic or wind- is more severe for the building, governs the design of the building and all attached equipment.**

The AT is offered with a choice of TWO structural design packages:

- Standard Structural Design – For projects with  $\leq 1.0$  g seismic or 60 psf wind loads
- Upgraded Structural Design – Required for projects with  $>1.0$  g or 60 psf wind loads and designed to meet highest seismic, 5.12 g or wind loads, 145 psf identified by IBC.

When using the EVAPCO selection software to make a selection, these calculations can be incorporated into the selection process. Simply enter the required factors and the Seismic Design Force and Wind Load will be calculated automatically.

Note: IBC 2009 Section 1603 requires all necessary information for determining seismic (and wind) loads to be provided in the Engineer-supplied Construction Documents.

U.S. Patent Nos. 7,938,373 and 7,963,492

### Independent Certification

ALL installations – Seismic or Wind Load – must meet the loads as outlined in the code. Additionally the IBC requires *independent seismic certification* for a specific category of installations. Installations that have a dominant seismic load and meet additional criteria, such as essential Occupancy categories, must be independently certified.

Equipment meeting the criteria must include all of the following:

- 1) Independent certification by a qualified professional engineer;
- 2) Labeling of the equipment;
- 3) A certificate of compliance by the manufacturer that is certified by the 3rd party engineer.

EVAPCO supplies a certificate of compliance as part of its submittal documents.

**In accordance with IBC 2009, EVAPCO's product lines have been independently certified that they can withstand seismic loads up to 1.0g or wind loads up to 60 psf in the standard design and 5.12g or 145 psf in the upgraded design.**

### OSHPD - California's Office of Statewide Health Planning and Development

California's Office of Statewide Health Planning and Development (OSHPD), which is responsible for interpretation of the CBC, issued a Code Application Notice (CAN 2-1708A.5, effective 10/31/2008 and latest revision 6/29/2009) where interpretations were detailed. OSHPD ruled that equipment with active components (such as the fan/drive system in a cooling tower) must be shake table tested.

EVAPCO used the OSHPD interpretation as an opportunity to take a leadership role in the industry. EVAPCO engaged two laboratories to perform multiple shake table tests between September 2009 and November 2010. The shake table test program validated our previous analysis and resulted in the independent certification and OSHPD approval of AT Cooling Towers with the upgraded structural design, OSP-0111-10.

Please note, all units sold into OSHPD governed projects must include the upgraded ("5.12g") design.

For questions regarding IBC or OSHPD compliance, please contact your local EVAPCO Representative or visit [www.evapco.com](http://www.evapco.com).

### Seismic Design

The chart shown below, from the US Geological Survey Website <http://www.usgs.gov/> shows the potential seismic activity in the United States. Buildings constructed in the red, orange and yellow areas of the map are most likely to require the upgraded AT construction design based on the site seismic design factors. Critical use facilities, such as hospitals, are also more likely to require the upgraded design.

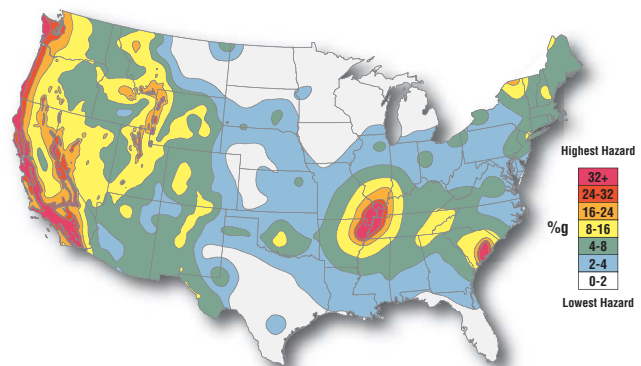

Map courtesy US Geological Survey website



IBC—INTERNATIONAL BUILDING CODE

# AT/UT/USS

AT

**Seismic Design** (cont.)

The project architect or civil engineer is responsible for determining the seismic design factors to be used for the building design. A mechanical consulting engineer and/or design build contractor will then apply these factors to a series of charts and graphs to determine the appropriate seismic design factors based on the location of the installation and ultimately the "importance" of the facility.

Design Facts:

- More than 80% of the United States has design criteria resulting in a seismic design force of 1.0g or below. These sites will be provided with the standard AT structural design.
- An upgraded structural design is available for installations with design criteria resulting in "g forces" greater than 1.0g.
- The highest "g force" location in North America is 5.12g. Therefore, the upgraded structural design package option for the AT is designed for 5.12g the AT applicable to ALL building locations in North America.
- There is no good translation from "g" to other seismic scales, such as the Richter scale.



Seismic Test Chamber

**Wind Design**

The IBC 2009 code book includes a map of basic wind speed (3-second gust) by contour lines. However, local regulations may be more stringent than these published speeds.

Whichever design force - seismic or wind - is more severe for the building, governs the design of the building and all attached equipment.

- More than 80% of the United States has design criteria resulting in a wind load of 60 psf or below. These sites will be provided with the standard AT structural design.
- An upgraded structural design is available for installations with design criteria resulting wind loads greater than 60 psf. These sites are most prevalent along the Gulf and Atlantic coast of the United States.
- The highest wind load shown on the IBC maps is (170 mph located in Guam) 150mph in the 50 states, which is approximately equal to 145 psf velocity pressure. Therefore, the upgraded structural design package option for the AT is designed to withstand 145 psf making the AT applicable to ALL building locations in North America.

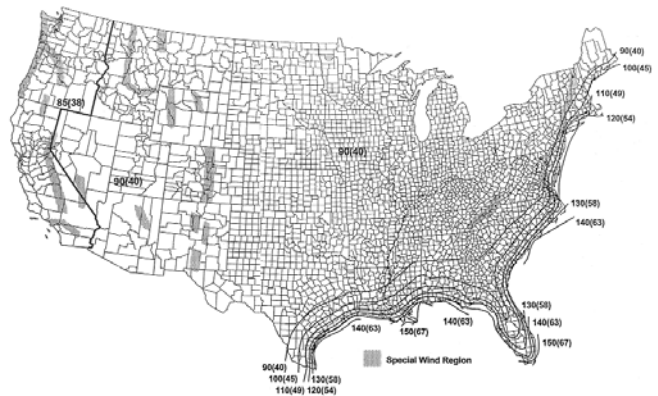

Wind Load Map Courtesy IBC 2009 Text – See full-sized map for location specific values

# AT/UT/USS

## OPTIONAL EQUIPMENT

### *Pulse~Pure*® Water Treatment System



The AT is available with EVAPCO's optional *Pulse~Pure*® non-chemical water treatment system. The *Pulse~Pure*® Water Treatment System utilizes pulsed-power technology to provide CHEMICAL FREE Water Treatment and is an environmentally responsible alternative for treating water in evaporative cooled equipment. It does not release harmful by-products to the environment and eliminates costly chemicals completely from tower drift and blowdown. The *Pulse~Pure*® system delivers short, high-frequency bursts of low energy electromagnetic fields to the recirculating water in the AT and will:

- Control Bacteria to Levels Well Below Most Chemical Water Treatment Programs.
- Control the Formation of Mineral Scale on Heat-Exchange Surfaces.
- Save Water by Operating at Higher Cycles of Concentration.
- Yield Corrosion Rates Equivalent to Most Chemical Water Treatment Programs.

EVAPCO's *Pulse~Pure*® Water Treatment System on the AT includes integral cutting edge conductivity control and blowdown packages that are contained in a single feeder panel.

**Conductivity Control Package** – Measures Conductivity Utilizing a Non-Fouling Torodial Probe and Features:

- One power connection of 120, 230 or 460 volt is all that is required.
- USB port for downloadable 60 day audit trail of system operation.

**Motorized Blowdown Valve** – Standard for the most reliable operation in bleed control. Two-way valve operation provides good bleed flow.

Because ongoing water treatment service is an absolute requirement for any evaporative cooled system, each purchase of a *Pulse~Pure*® Water Treatment System includes, as standard, a 1 year water treatment service and monitoring contract provided by your factory trained EVAPCO Service Representative.

EVAPCO's *Pulse~Pure*® system offers AT owners a single-source of responsibility for equipment, water treatment and service.

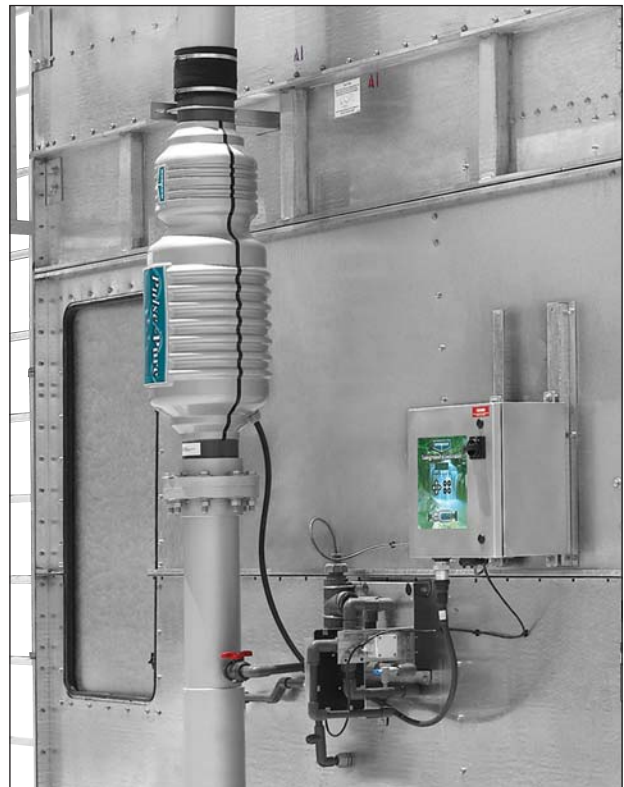

U.S. Patent Nos. 7,704,364 and 7,981,288





# ULTRA-QUIET

COOLING TOWERS

# ULTRA SST

UT & USS



304 ss

316 ss



**ULTRA-QUIET OPERATION**  
IN INDUCED DRAFT,  
COUNTERFLOW COOLING TOWERS

**100%**  
CORROSION-RESISTANT  
TOWER



*TECHNOLOGY FOR THE FUTURE, AVAILABLE TODAY!*

## Solutions for Sound Sensitive Applications

The **ULTRA-QUIET**® Cooling Tower comes standard with Super Low Sound Fan that reduces the overall sound generated from the top of the cooling tower. The **ULTRA-QUIET**® cooling tower provides deep sound reductions and can be used in combination with Water Silencers to produce the lowest sound levels commercially available. Consult EVAPCO's evapSelect® selection software for unit sound levels. If a detailed analysis or full octave band datasheet is required for your application, please consult your EVAPCO Sales Representative.

10 dB(A) decrease is half as loud! The **ULTRA-QUIET**® tower reduces noise pollution by **more than 50%**.  
(For more information see Sound Basics on pages 19-21)



### CTI Certified-Standard 201

- Independent Certification.
- No costly field performance tests required.



### The Super Low Sound Fan Reduced Sound Levels versus Model AT Standard Fan

EVAPCO's Super Low Sound Fan on the **ULTRA-QUIET**® cooling tower utilizes an extremely wide chord blade design available for sound sensitive applications where the lowest sound levels are desired. The fan is two-piece molded heavy duty FRP construction utilizing a forward swept blade design. The Super Low Sound Fan reduces sound levels 9 to 15 dB(A) compared to the Model AT standard fan. (Not available on 4 ft. wide models)

*All of the same great features as an AT tower with a quieter fan.*

### Improved Sound Quality versus Model AT Standard Fan

The **SUPER** Low Sound Fan on the **ULTRA-QUIET**® cooling tower reduces sound levels 9-15 dB(A) and eliminates audible blade passing frequencies indicative of straight bladed axial type fans.

Refer to the Narrow Band Spectrum graph which shows how straight bladed axial fans produce blade passing frequencies – the same phenomena that produce the signature pulsating helicopter noise.

The blade passing frequencies are audible spikes in sound pressure levels, but are not apparent in the octave band sound spectrum.



The Super Low Sound Fan on the **ULTRA-QUIET**® Cooling Tower reduces sound levels and improves the sound quality!

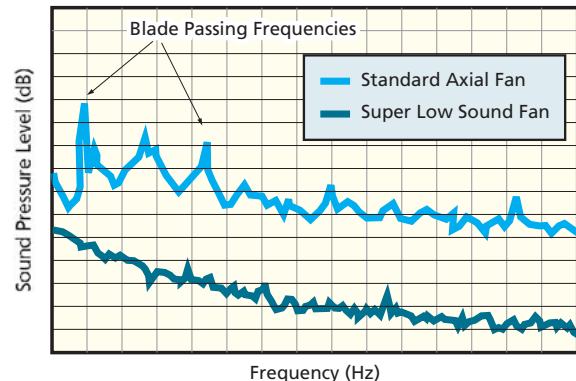

Narrow Band Spectrum Analysis



# AT/UT/USS

## SOUND BASICS

### Background in Sound Basics

#### Sound

Sound is the alteration in pressure, stress, particle displacement and particle velocity, which is propagated in an elastic material. Audible sound is the sensation produced at the ear by very small pressure fluctuations in the air.

#### Sound Pressure

Sound pressure is the *intensity* of sound. Sound pressure,  $L_p$  in decibels is the ratio of measured pressure,  $P$  in the air to a reference sound pressure,  $P_0 = 2 \times 10^{-5}$  Pascal following the following formula:

$$L_p \text{ (dB)} = 10 \log_{10} (\Delta P^2 / \Delta P_0^2)$$

The most important point to understand about sound pressure level is that **sound pressure level is what is actually being measured when sound data is recorded**. Microphones that measure sound are pressure sensitive devices that are calibrated to convert the sound pressure waves into decibels.

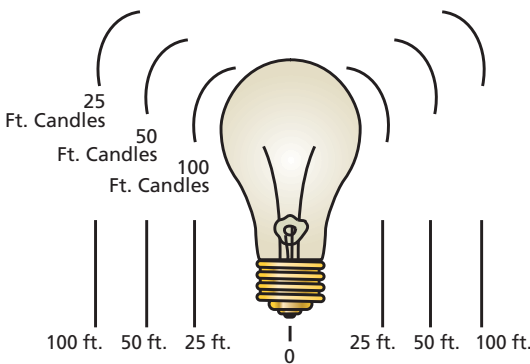

“SOUND PRESSURE”

Similar to the intensity coming from a light bulb which gets dimmer as one gets further and further away, sound pressure decreases in decibels as your ear gets further from the sound source.

#### Sound Power

Sound Power is the *energy* of sound. Sound power,  $L_w$  in decibels is the ratio of the calculated sound power,  $W$  to a reference power,  $W_0 = 1$  picowatt, according to the following formula:

$$L_w \text{ (dB)} = 10 \log_{10} (W/W_0)$$

The most important point to remember about sound power level is that **sound power level is not a measured value, but is calculated based on the measured sound pressure.**

ured value, but is calculated based on the measured sound pressure.

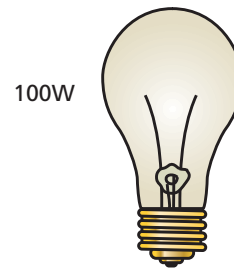

“SOUND POWER”

Similar to the wattage of a light bulb that does not change the farther one is away from the light bulb, sound power does not vary with distance.

#### Adding Multiple Sound Sources

Since the decibel is a logarithmic function, the numbers are not added linearly. Therefore, two 73 dB sound sources added together do not equal 146 dB. The resultant sound would actually be 76 dB. The following table shows how to add decibels from two sound sources.

Difference in dB Level	Add to the higher dB Level
0 to 1	3
2 to 3	2
4 to 8	1
9 or greater	0

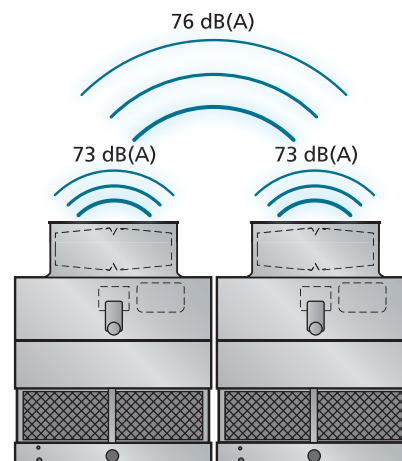

# AT/UT/USS

## SOUND BASICS

### Sound Science and Cooling Towers

#### Sound Frequency

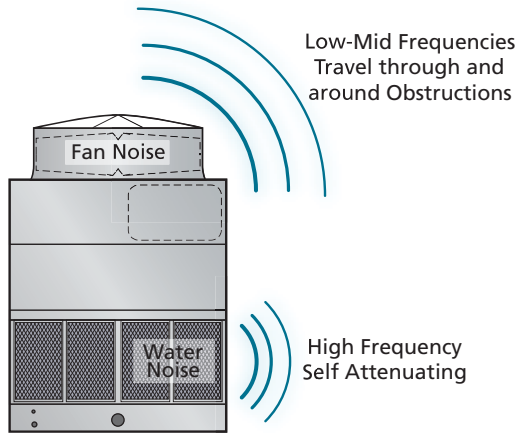

#### Fan Noise

- Low / Mid frequencies that travel long distances, through walls, and around obstructions.
- Very difficult to attenuate. Reduce fan noise by using Low Sound Fans.
- Dominates what is measured and heard at the cooling tower and at the sound sensitive location.

#### Water Noise

- High frequencies that attenuate naturally with distance. Attenuated easily by walls, trees or other obstructions.
- Totally masked and drowned out by fan noise at a short distance away from the cooling tower.

### Sound Pressure – The A-Weighted Scale

The A-weighted scale, dB(A) is a means to translate what a sound meter microphone measures to how the human ear perceives the sound.

#### dB(A) Formula and Conversions:

$$dB(A) = 10 \log_{10} \sum_{f=63}^{f=8000} 10^{((dB+C_f)/10)}$$

where:  $C_f$  = correction factor per band  
 $dB$  = measured sound pressure  
 let:  $Z_f = (dB + C_f)/10$

Band	Center Freq. (Hz)	Frequency Range (Hz)	Sample Data (dB)	$C_f$ (dB)	$Z_f$
1	63	44-88	68	-26.2	4.18
2	125	89-175	76	-16.1	5.99
3	250	176-350	77	-8.6	6.84
4	500	351-700	73	-3.2	6.98
5	1000	701-1400	70	0	7.00
6	2000	1401-2800	68	+1.2	6.92
7	4000	2801-5600	71	+1.0	7.20
8	8000	5601-11200	73	-1.1	7.19

#### Typical Sound Pressure Levels of Well Known Noises:

Jet Airplane, 150 feet away	140 dB(A)
Painful	130 dB(A)
Very Uncomfortable	120 dB(A)
Circular Saw	110 dB(A)
Nightclub	100 dB(A)
Semi Truck	90 dB(A)
Sidewalk of a Busy Road	80 dB(A)
Household Vacuum, 3 feet away	70 dB(A)
Normal Conversation	60 dB(A)
Inside Average Home	50 dB(A)
Quiet Library	40 dB(A)
Bedroom at Night	30 dB(A)

#### Notable Facts about Sound:

- +/- 1 dB(A) is inaudible to the human ear
- Decreasing a noise source by 10 dB(A) sounds half as loud to the human ear

#### Example calculation of the dB(A) formula using the Sample Data above.

$$dB(A) = 10 \log_{10} \sum 10^{(Z_1)} + 10^{(Z_2)} + 10^{(Z_3)} + 10^{(Z_4)} + 10^{(Z_5)} + 10^{(Z_6)} + 10^{(Z_7)} + 10^{(Z_8)}$$

$$= 10 \log_{10} (67114245.2) = 78.3 \text{ dB(A)}$$



## SOUND BASICS

### Specifying Sound – A Performance Specification

**Specify sound pressure in dB(A) measured 5 feet above the fan discharge during full speed operation.**

- All manufacturers can meet a performance specification with Low Sound Options
- Fan noise is what matters. 5 feet above the fan is where it matters.

#### Measurement Location

**Per Cooling Technology Institute Standard ATC-128**

Sound Microphone location 5 feet above the cooling tower fan cowl edge at a 45° angle.

This position assures accurate sound measurements by eliminating a source of uncertainty by taking the microphone out of the high velocity fan discharge air.

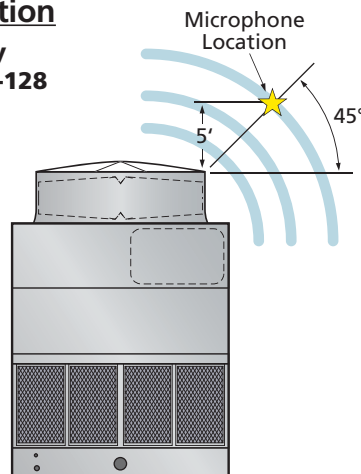

#### Easy Verification

At 5 feet from the cooling tower, a sound meter records only cooling tower noise. Interested parties can easily verify the actual noise coming from the cooling tower against the specified sound data with good certainty.

If sound were specified at 50 feet or some greater distance from the sound sensitive location, there is increased uncertainty in the measured data due to other possible sound sources within the 50 foot radius of the sound microphone.

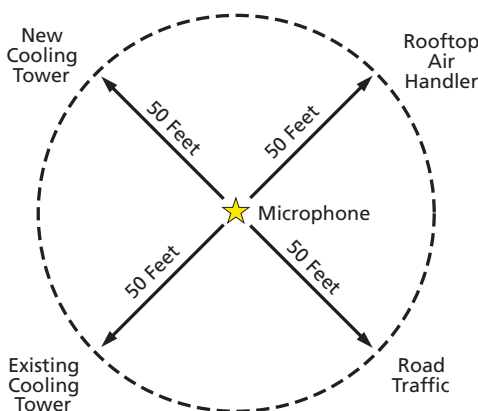

#### Sound Quality

Sound coming from the top of the cooling tower is comprised of low- and mid-frequency fan noise. Low- and mid-frequency fan “rumble” is very difficult to attenuate. Fan rumble travels through everything and around everything and is what is audible at any sound sensitive location.

Sound coming from the sides of the cooling tower is comprised of high frequency water noise, is much less objectionable than fan noise and attenuates naturally with distance.

#### Acoustical Shadow\*

“Subjective reactions to the overall noise generated by cooling towers indicate that as one walks away from a tower intake, a point is reached where the water noise is masked by the fan noise. The point coincides with the point at which one emerges from the acoustical shadow of the tower structure, which shields intake water noise from discharge fan noise.”

\*Seelbach & Oran, “What To Do About Cooling Tower Noise”, Industrial Acoustics Company.

Sound measured at the side of a cooling tower is inside the acoustical shadow of the noise emitted from the top. Outside the acoustical shadow, the low- and mid-frequency fan noise completely masks the high frequency water noise.

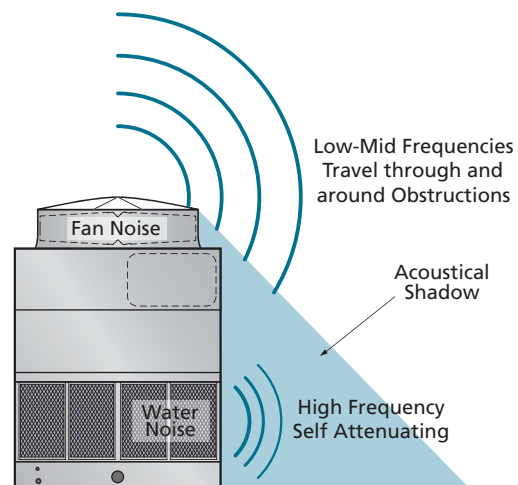

**Specify fan noise because it matters!  
Specify fan noise where it matters!**

# ULTRA SST

**A 100% CORROSION-RESISTANT DESIGN  
COMPLETE STAINLESS STEEL CONSTRUCTION**

EVAPCO, Inc., continues to set the standard in the cooling tower industry with the **Ultra-SST**. The **Ultra-SST** is the finest factory assembled cooling tower ever offered. It is the ONLY ALL Stainless Steel cooling tower offered with a Type 316 SS basin AS STANDARD! Constructed of the highest quality materials, the **Ultra-SST** provides the Ultimate in corrosion protection.

The **Ultra-SST** is a 100% corrosion-resistant cooling tower constructed of stainless steel. The premium components include:

**Type 316 Stainless Steel**

- Cold water basin
- Vertical support columns
- Air inlet louver frames
- Plenum

**Type 304 Stainless Steel**

- Upper casing and structure
- Mechanical equipment support
- Fan Cowl and Fan Guard

*The same easy maintenance highly efficient design as an AT tower with even more durable construction.*



**CTI Certified-Standard 201**

- Independent Certification.
- No costly field performance tests required.

**PVC**

- EVAPAK® Fill
- Water distribution system
- Patented Air inlet louvers
- Patented Drift eliminators



EVAPCO offers the **Ultra-SST** cooling tower with a standard Type 316 stainless steel cold water basin. Since the cold water basin provides the structural support for the unit and is the area most susceptible to corrosion, it is constructed with the highest quality materials. The **Ultra-SST** is the ONLY cooling tower in the industry that offers this protection as standard.



**Exclusive 5 Year Complete Product Warranty**

- Covers the complete drive system, including the motor, on belt or gear drive units.
- Covers the complete cooling tower from the cold water basin to the fan discharge screen.
- Standard on all Ultra-SST Models.

**A 100% CORROSION-RESISTANT TOWER**

**Complete 316 SS Construction Available**  
For a small price addition, the **Ultra-SST** can be upgraded to complete Type 316 SS construction.

† Mark owned by the Cooling Technology Institute

# AT/UT/USS

## ENGINEERING DATA & DIMENSIONS







# AT/UT/USS

## NOMENCLATURE

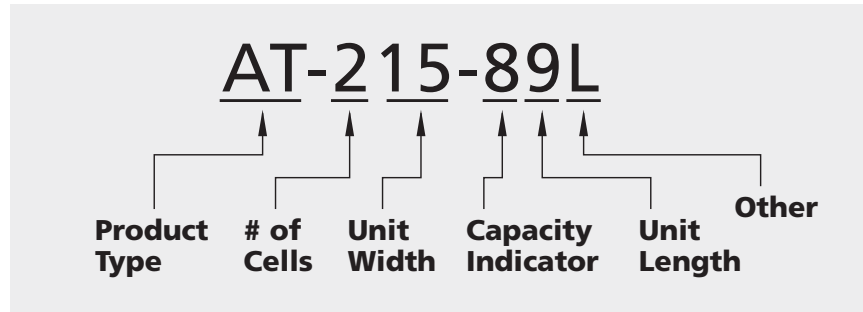

### **Product Type**

AT – Indicates an AT tower

UT – An AT with a Super Low Sound Fan

USS - An AT tower with stainless steel construction, 304, 316 or a combination. A USS tower may also include a Super Low Sound Fan.

### **# of Cells**

Determined by the number of inlet connections, can be 1, 2, 3, or 4

### **Unit Width**

The total width of the unit in feet, all cells included. The value is rounded up to the next whole number.

### **Capacity Indicator**

Relative performance indicator, an AT-215-89 has more capacity than an AT-215-49.

### **Unit Length**

The total length of the unit in feet, all cells included. The value is rounded up to the next whole number.

### **Other**

Some, but not all units end with a letter.

L – Indicates a reduced horsepower motor.

S – Indicates a non-cataloged design.

## ENGINEERING DATA & DIMENSIONS

### MODELS: AT/USS 14-64 to 14-96

One-Cell Cooling Towers

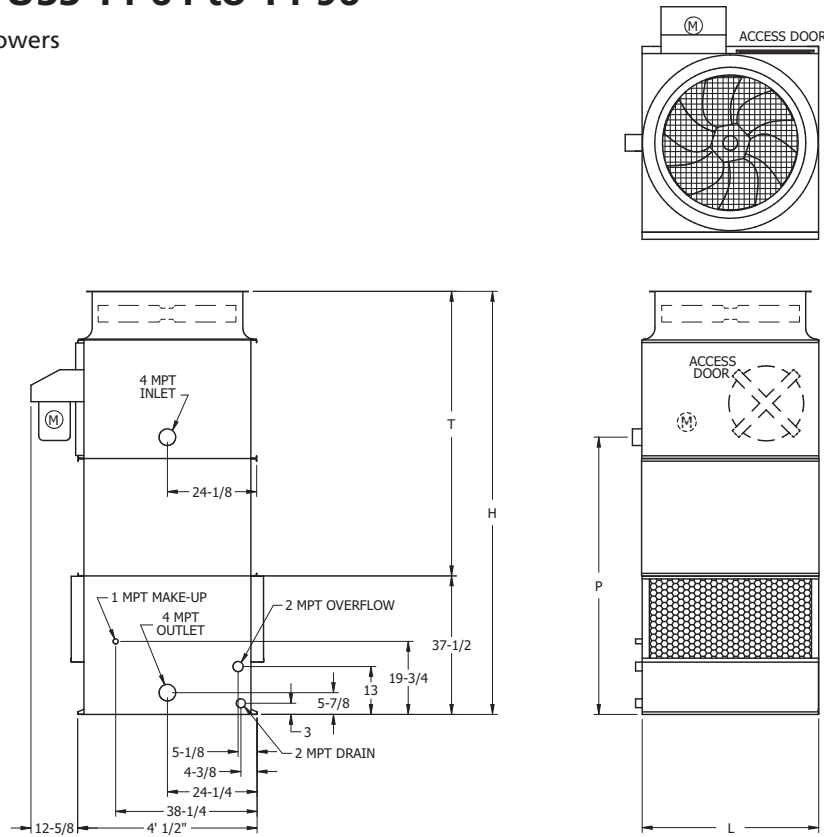

ONE CELL

Model No.	Nominal Tonnage	Weights (LBS)			Fan Motor (HP)	Air Flow (CFM)	Dimensions			
		Shipping	Operating	Heaviest Section <sup>†</sup>			H <sup>†</sup>	T <sup>†</sup>	P	L
AT 14-64	33	1,080	1,760	730	2	9,600	9' 6-1/2"	6' 5"	6' 3"	3' 11-3/4"
AT 14-74	37	1,160	1,840	810	2	9,500	10' 6-1/2"	7' 5"	7' 3"	3' 11-3/4"
AT 14-84	39	1,130	1,810	780	3	10,900	9' 6-1/2"	6' 5"	6' 3"	3' 11-3/4"
AT 14-94	43	1,210	1,890	860	3	10,700	10' 6-1/2"	7' 5"	7' 3"	3' 11-3/4"
AT 14-66	57	1,390	2,460	950	3	15,300	9' 6-1/2"	6' 5"	6' 3"	5' 11-3/4"
AT 14-76	64	1,490	2,560	1,050	3	15,100	10' 6-1/2"	7' 5"	7' 3"	5' 11-3/4"
AT 14-86	67	1,410	2,480	970	5	18,000	9' 6-1/2"	6' 5"	6' 3"	5' 11-3/4"
AT 14-96	74	1,510	2,580	1,070	5	17,700	10' 6-1/2"	7' 5"	7' 3"	5' 11-3/4"

NOTE: (1) An adequately sized bleed line must be installed in the cooling tower system to prevent build-up of impurities in the recirculated water.  
 (2) Do not use catalog drawings for certified prints. Dimensions and weights are subject to change.  
 (3) Adequate spacing must be allowed for access to the cooling tower. Refer to EVAPCO's Equipment Layout Manual.  
 (4) Nominal Tonnage is based on 3 gpm per ton at 95 degree entering water temperature, 85 degree leaving water temperature, and 78 degree wet-bulb temperature.

† Heaviest section is upper section.  
 † Height includes fan guard which ships factory mounted.



# AT/UT/USS

## ENGINEERING DATA & DIMENSIONS

### MODELS: AT/USS 14-69 to 14-912

One-Cell Cooling Towers

\*14-69 to 14-99  
(1) 4" Inlet  
(1) 4" Outlet

\*14-612 to 14-912  
(1) 6" Inlet  
(1) 6" Outlet

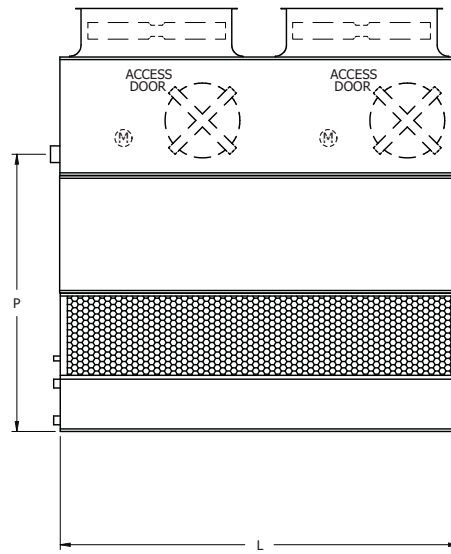
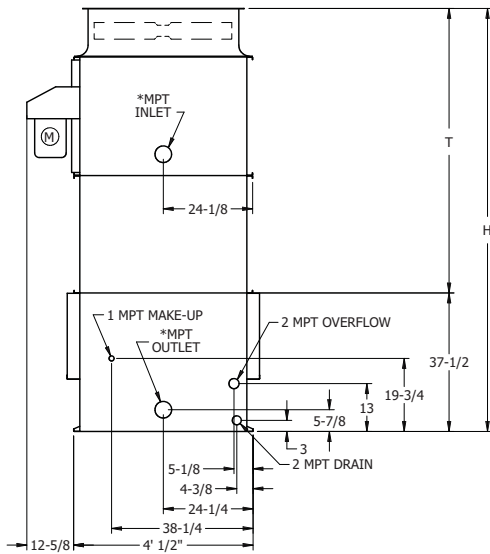
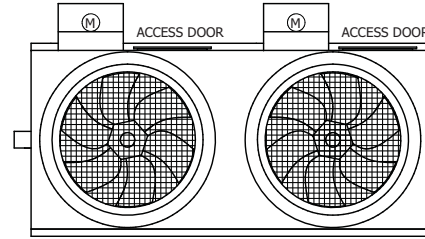

Model No.	Nominal Tonnage	Weights (LBS)			Fan Motor (HP)	Air Flow (CFM)	Dimensions			
		Shipping	Operating	Heaviest Section <sup>†</sup>			H <sup>†</sup>	T <sup>†</sup>	P	L
AT 14-69	76	2,000	3,600	1,380	(2) 2	21,200	9' 6-1/2"	6' 5"	6' 3"	8' 11-3/4"
AT 14-79	86	2,160	3,760	1,540	(2) 2	20,800	10' 6-1/2"	7' 5"	7' 3"	8' 11-3/4"
AT 14-89	90	2,100	3,700	1,480	(2) 3	24,100	9' 6-1/2"	6' 5"	6' 3"	8' 11-3/4"
AT 14-99	100	2,260	3,860	1,640	(2) 3	23,600	10' 6-1/2"	7' 5"	7' 3"	8' 11-3/4"
AT 14-612	115	2,530	4,700	1,770	(2) 3	31,000	9' 6-1/2"	6' 5"	6' 3"	11' 11-3/4"
AT 14-712	129	2,730	4,900	1,970	(2) 3	30,400	10' 6-1/2"	7' 5"	7' 3"	11' 11-3/4"
AT 14-812	137	2,570	4,740	1,810	(2) 5	36,400	9' 6-1/2"	6' 5"	6' 3"	11' 11-3/4"
AT 14-912	150	2,770	4,940	2,010	(2) 5	35,700	10' 6-1/2"	7' 5"	7' 3"	11' 11-3/4"

NOTE: (1) An adequately sized bleed line must be installed in the cooling tower system to prevent build-up of impurities in the recirculated water.  
 (2) Do not use catalog drawings for certified prints. Dimensions and weights are subject to change.  
 (3) Adequate spacing must be allowed for access to the cooling tower. Refer to EVAPCO's Equipment Layout Manual.  
 (4) Nominal Tonnage is based on 3 gpm per ton at 95 degree entering water temperature, 85 degree leaving water temperature, and 78 degree wet-bulb temperature.

♦ Heaviest section is upper section.  
 † Height includes fan guard which ships factory mounted.



## ENGINEERING DATA & DIMENSIONS

### MODELS: AT/UT/USS 19-56 to 19-98

One-Cell Cooling Towers

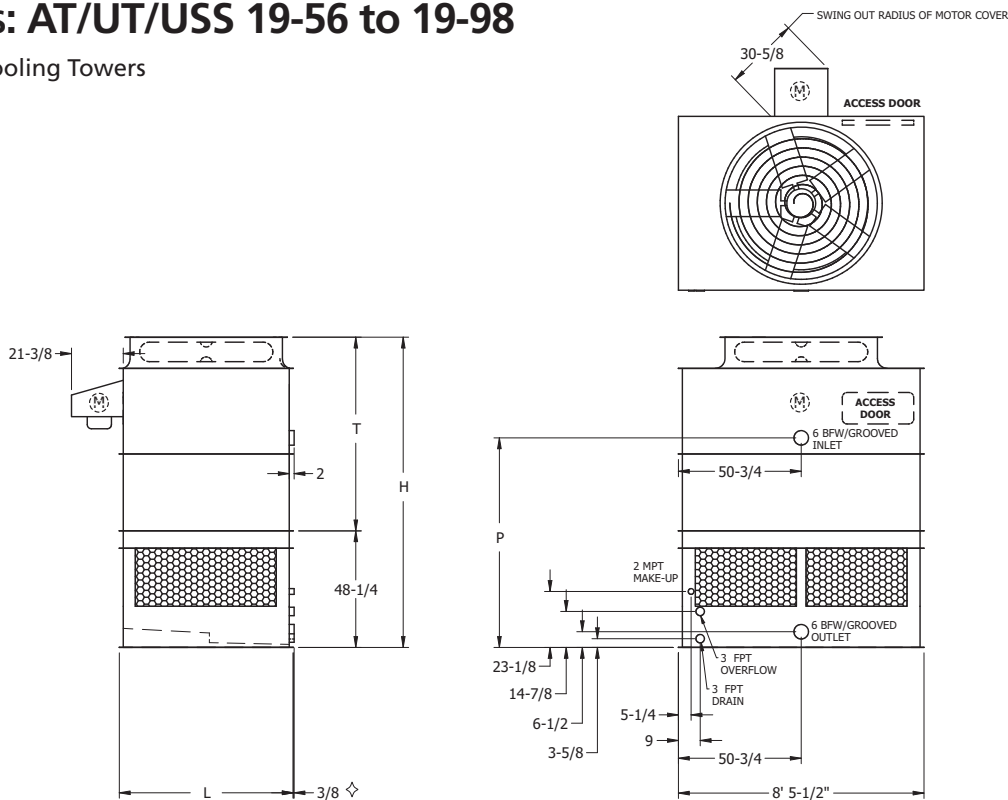

ONE CELL

Model No.	Nominal Tonnage	Weights (LBS)			Fan Motor (HP)	Air Flow (CFM)	Dimensions			
		Shipping	Operating	Heaviest Section <sup>†</sup>			H <sup>†</sup>	T <sup>†</sup>	P	L
AT 19-56L	89	3,000	5,040	1,950	3	22,600	10' 8-1/4"	6' 8"	7' 2-1/2"	5' 11-7/8"
AT 19-56	112	3,060	5,100	2,010	5	26,500	10' 8-1/4"	6' 8"	7' 2-1/2"	5' 11-7/8"
AT 19-66	123	3,100	5,140	2,050	7.5	30,200	10' 8-1/4"	6' 8"	7' 2-1/2"	5' 11-7/8"
AT 19-76L	124	3,260	5,300	2,210	5	26,100	11' 8-1/4"	7' 8"	8' 2-1/2"	5' 11-7/8"
AT 19-76	138	3,300	5,340	2,250	7.5	29,700	11' 8-1/4"	7' 8"	8' 2-1/2"	5' 11-7/8"
AT 19-86	150	3,330	5,370	2,280	10	32,500	11' 8-1/4"	7' 8"	8' 2-1/2"	5' 11-7/8"
AT 19-96L	157	3,550	5,590	2,500	10	32,000	12' 8-1/4"	8' 8"	9' 2-1/2"	5' 11-7/8"
AT 19-96	171	3,620	5,660	2,570	15	36,300	12' 8-1/4"	8' 8"	9' 2-1/2"	5' 11-7/8"
UT Addition		+	150	150			1' 1"	1' 1"		
AT 19-28L	109	3,390	5,810	2,220	3	26,600	10' 8-1/4"	6' 8"	7' 2-1/2"	7' 5-7/8"
AT 19-28	137	3,450	5,870	2,280	5	31,300	10' 8-1/4"	6' 8"	7' 2-1/2"	7' 5-7/8"
AT 19-38	148	3,490	5,910	2,320	7.5	35,700	10' 8-1/4"	6' 8"	7' 2-1/2"	7' 5-7/8"
AT 19-48	159	3,520	5,940	2,350	10	39,200	10' 8-1/4"	6' 8"	7' 2-1/2"	7' 5-7/8"
AT 19-58L	152	3,680	6,100	2,510	5	30,800	11' 8-1/4"	7' 8"	8' 2-1/2"	7' 5-7/8"
AT 19-58	165	3,720	6,140	2,550	7.5	35,100	11' 8-1/4"	7' 8"	8' 2-1/2"	7' 5-7/8"
AT 19-68	179	3,750	6,170	2,580	10	37,800	11' 8-1/4"	7' 8"	8' 2-1/2"	7' 5-7/8"
AT 19-78L	173	3,990	6,410	2,820	7.5	34,500	12' 8-1/4"	8' 8"	9' 2-1/2"	7' 5-7/8"
AT 19-78	187	4,020	6,440	2,850	10	37,800	12' 8-1/4"	8' 8"	9' 2-1/2"	7' 5-7/8"
AT 19-88	197	3,810	6,230	2,640	15	43,700	11' 8-1/4"	7' 8"	8' 2-1/2"	7' 5-7/8"
AT 19-98	207	4,080	6,500	2,910	15	43,000	12' 8-1/4"	8' 8"	9' 2-1/2"	7' 5-7/8"
UT Addition		+	150	150			1' 5"	1' 5"		

NOTE: (1) An adequately sized bleed line must be installed in the cooling tower system to prevent build-up of impurities in the recirculated water.  
 (2) Do not use catalog drawings for certified prints. Dimensions and weights are subject to change.  
 (3) Adequate spacing must be allowed for access to the cooling tower. Refer to EVAPCO's Equipment Layout Manual.  
 (4) Nominal Tonnage is based on 3 gpm per ton at 95 degree entering water temperature, 85 degree leaving water temperature, and 78 degree wet-bulb temperature.

- ◇ Outlet connection extends 3/8" beyond bottom flange.
- † Heaviest section is upper section.
- † Height includes fan guard which ships factory mounted.
- ⊕ Please consult the factory for additional information regarding shipping and section weight changes.



# AT/UT/USS

## ENGINEERING DATA & DIMENSIONS

### MODELS: AT/UT/USS 19-59 to 19-911

One-Cell Cooling Towers

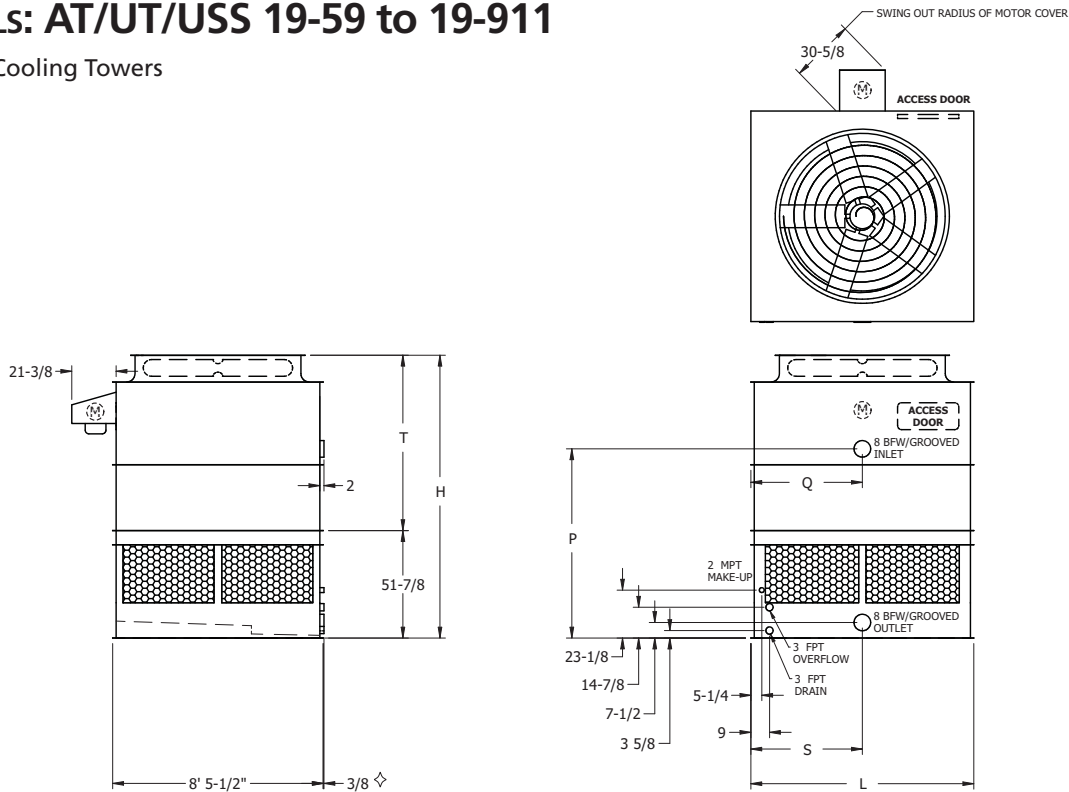

Model No.	Nominal Tonnage	Weights (LBS)			Fan Motor (HP)	Air Flow (CFM)	Dimensions				
		Shipping	Operating	Heaviest Section†			H†	T†	P	L	S&Q
AT 19-59L	181	4,290	7,130	2,980	7.5	40,100	12' 4-3/8"	8' 1/2"	8' 7-1/8"	8' 11-1/2"	4' 5-3/4"
AT 19-59	199	4,320	7,160	3,010	10	43,900	12' 4-3/8"	8' 1/2"	8' 7-1/8"	8' 11-1/2"	4' 5-3/4"
AT 19-69L	178	4,050	6,890	2,740	10	44,700	11' 4-3/8"	7' 1/2"	7' 7-1/8"	8' 11-1/2"	4' 5-3/4"
AT 19-69	208	4,120	6,960	2,810	15	50,800	11' 4-3/8"	7' 1/2"	7' 7-1/8"	8' 11-1/2"	4' 5-3/4"
AT 19-79	232	4,390	7,230	3,080	15	49,800	12' 4-3/8"	8' 1/2"	8' 7-1/8"	8' 11-1/2"	4' 5-3/4"
AT 19-89L	209	4,630	7,470	3,320	10	43,200	13' 4-3/8"	9' 1/2"	9' 7-1/8"	8' 11-1/2"	4' 5-3/4"
AT 19-89	242	4,700	7,540	3,390	15	49,000	13' 4-3/8"	9' 1/2"	9' 7-1/8"	8' 11-1/2"	4' 5-3/4"
AT 19-99	265	4,750	7,590	3,440	20	53,600	13' 4-3/8"	9' 1/2"	9' 7-1/8"	8' 11-1/2"	4' 5-3/4"
UT Addition		✦	150	150			1' 9"	1' 9"			
AT 19-111L	156	4,530	7,830	3,060	5	40,200	11' 4-3/8"	7' 1/2"	7' 7-1/8"	10' 5-1/2"	5' 2-3/4"
AT 19-111	187	4,570	7,870	3,100	7.5	45,800	11' 4-3/8"	7' 1/2"	7' 7-1/8"	10' 5-1/2"	5' 2-3/4"
AT 19-211	202	4,600	7,900	3,130	10	50,200	11' 4-3/8"	7' 1/2"	7' 7-1/8"	10' 5-1/2"	5' 2-3/4"
AT 19-311L	202	4,890	8,190	3,420	7.5	45,100	12' 4-3/8"	8' 1/2"	8' 7-1/8"	10' 5-1/2"	5' 2-3/4"
AT 19-311	221	4,920	8,220	3,450	10	49,400	12' 4-3/8"	8' 1/2"	8' 7-1/8"	10' 5-1/2"	5' 2-3/4"
AT 19-411	231	4,670	7,970	3,200	15	57,100	11' 4-3/8"	7' 1/2"	7' 7-1/8"	10' 5-1/2"	5' 2-3/4"
AT 19-511	256	4,990	8,290	3,520	15	56,100	12' 4-3/8"	8' 1/2"	8' 7-1/8"	10' 5-1/2"	5' 2-3/4"
AT 19-611L	238	5,270	8,570	3,800	10	48,600	13' 4-3/8"	9' 1/2"	9' 7-1/8"	10' 5-1/2"	5' 2-3/4"
AT 19-611	270	5,340	8,640	3,870	15	55,100	13' 4-3/8"	9' 1/2"	9' 7-1/8"	10' 5-1/2"	5' 2-3/4"
AT 19-711	285	5,040	8,340	3,570	20	61,300	12' 4-3/8"	8' 1/2"	8' 7-1/8"	10' 5-1/2"	5' 2-3/4"
AT 19-811	298	5,390	8,690	3,920	20	60,300	13' 4-3/8"	9' 1/2"	9' 7-1/8"	10' 5-1/2"	5' 2-3/4"
AT 19-911	314	5,420	8,720	3,950	25	64,600	13' 4-3/8"	9' 1/2"	9' 7-1/8"	10' 5-1/2"	5' 2-3/4"
UT Addition		✦	150	150			1' 9"	1' 9"			

NOTE: (1) An adequately sized bleed line must be installed in the cooling tower system to prevent build-up of impurities in the recirculated water.  
 (2) Do not use catalog drawings for certified prints. Dimensions and weights are subject to change.  
 (3) Adequate spacing must be allowed for access to the cooling tower. Refer to EVAPCO's Equipment Layout Manual.  
 (4) Nominal Tonnage is based on 3 gpm per ton at 95 degree entering water temperature, 85 degree leaving water temperature, and 78 degree wet-bulb temperature.

- ◇ Outlet connection extends 3/8" beyond bottom flange.
- ✦ Heaviest section is upper section.
- † Height includes fan guard which ships factory mounted.
- ✦ Please consult the factory for additional information regarding shipping and section weight changes.

## ENGINEERING DATA & DIMENSIONS

### MODELS: AT/UT/USS 19-412 to 19-914

One-Cell Cooling Towers

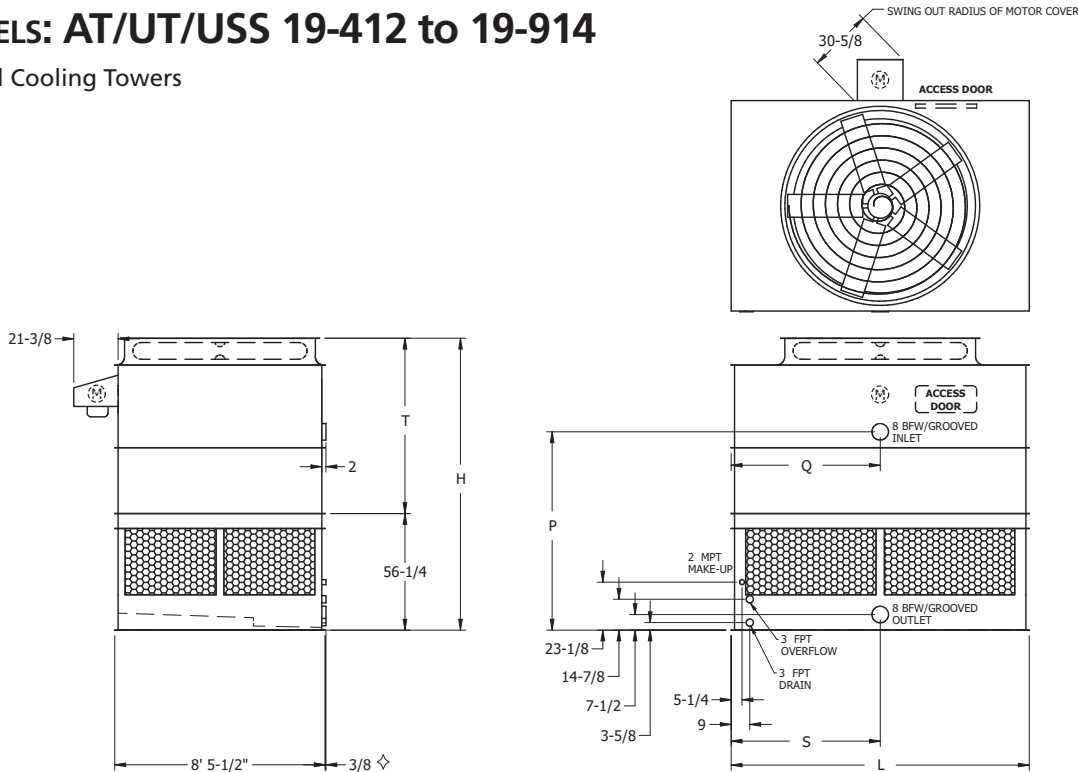

ONE CELL

Model No.	Nominal Tonnage	Weights (LBS)			Fan Motor (HP)	Air Flow (CFM)	Dimensions				
		Shipping	Operating	Heaviest Section <sup>†</sup>			H <sup>†</sup>	T <sup>†</sup>	P	L	S&Q
AT 19-412L	257	5,190	9,050	3,540	15	63,100	11' 8-3/4"	7' 1/2"	7' 11-1/2"	11' 11-3/4"	11' 11-3/4"
AT 19-412	283	5,230	9,090	3,580	20	69,100	11' 8-3/4"	7' 1/2"	7' 11-1/2"	11' 11-3/4"	11' 11-3/4"
AT 19-512L	256	5,470	9,330	3,820	10	54,500	12' 8-3/4"	8' 1/2"	8' 11-1/2"	11' 11-3/4"	11' 11-3/4"
AT 19-512	289	5,550	9,410	3,900	15	61,900	12' 8-3/4"	8' 1/2"	8' 11-1/2"	11' 11-3/4"	11' 11-3/4"
AT 19-612	319	5,590	9,450	3,940	20	67,800	12' 8-3/4"	8' 1/2"	8' 11-1/2"	11' 11-3/4"	11' 11-3/4"
AT 19-712L	299	5,940	9,800	4,290	15	61,000	13' 8-3/4"	9' 1/2"	9' 11-1/2"	11' 11-3/4"	11' 11-3/4"
AT 19-712	330	5,980	9,840	4,330	20	66,700	13' 8-3/4"	9' 1/2"	9' 11-1/2"	11' 11-3/4"	11' 11-3/4"
AT 19-812	340	5,610	9,470	3,960	25	72,800	12' 8-3/4"	8' 1/2"	8' 11-1/2"	11' 11-3/4"	11' 11-3/4"
AT 19-912	363	6,020	9,880	4,370	30	75,800	13' 8-3/4"	9' 1/2"	9' 11-1/2"	11' 11-3/4"	11' 11-3/4"
UT Addition		✦	150	150			1' 9"	1' 9"			
AT 19-114L	221	5,540	10,050	3,680	7.5	55,900	11' 8-3/4"	7' 1/2"	7' 11-1/2"	13' 11-3/4"	13' 11-3/4"
AT 19-114	251	5,570	10,080	3,710	10	61,300	11' 8-3/4"	7' 1/2"	7' 11-1/2"	13' 11-3/4"	13' 11-3/4"
AT 19-214L	249	5,950	10,460	4,090	7.5	55,100	12' 8-3/4"	8' 1/2"	8' 11-1/2"	13' 11-3/4"	13' 11-3/4"
AT 19-214	280	5,980	10,490	4,120	10	60,300	12' 8-3/4"	8' 1/2"	8' 11-1/2"	13' 11-3/4"	13' 11-3/4"
AT 19-314	309	5,690	10,200	3,830	20	76,500	11' 8-3/4"	7' 1/2"	7' 11-1/2"	13' 11-3/4"	13' 11-3/4"
AT 19-414	315	6,060	10,570	4,200	15	68,600	12' 8-3/4"	8' 1/2"	8' 11-1/2"	13' 11-3/4"	13' 11-3/4"
AT 19-514L	295	6,430	10,940	4,570	10	59,300	13' 8-3/4"	9' 1/2"	9' 11-1/2"	13' 11-3/4"	13' 11-3/4"
AT 19-514	329	6,510	11,020	4,650	15	67,500	13' 8-3/4"	9' 1/2"	9' 11-1/2"	13' 11-3/4"	13' 11-3/4"
AT 19-614	347	6,100	10,610	4,240	20	75,000	12' 8-3/4"	8' 1/2"	8' 11-1/2"	13' 11-3/4"	13' 11-3/4"
AT 19-714	377	6,120	10,630	4,260	25	80,400	12' 8-3/4"	8' 1/2"	8' 11-1/2"	13' 11-3/4"	13' 11-3/4"
AT 19-814	399	6,140	10,650	4,280	30	85,200	12' 8-3/4"	8' 1/2"	8' 11-1/2"	13' 11-3/4"	13' 11-3/4"
AT 19-914	413	6,590	11,100	4,730	30	83,800	13' 8-3/4"	9' 1/2"	9' 11-1/2"	13' 11-3/4"	13' 11-3/4"
UT Addition		✦	150	150			1' 9"	1' 9"			

NOTE: (1) An adequately sized bleed line must be installed in the cooling tower system to prevent build-up of impurities in the recirculated water.  
 (2) Do not use catalog drawings for certified prints. Dimensions and weights are subject to change.  
 (3) Adequate spacing must be allowed for access to the cooling tower. Refer to EVAPCO's Equipment Layout Manual.  
 (4) Nominal Tonnage is based on 3 gpm per ton at 95 degree entering water temperature, 85 degree leaving water temperature, and 78 degree wet-bulb temperature.

- ✦ Outlet connection extends 3/8" beyond bottom flange.
- † Heaviest section is upper section.
- † Height includes fan guard which ships factory mounted.
- ✦ Please consult the factory for additional information regarding shipping and section weight changes.





# AT/UT/USS

## ENGINEERING DATA & DIMENSIONS

### MODELS: AT/UT/USS 110-112 to 110-918

One-Cell Cooling Towers

- \*110-112 to 110-912  
(1) 8" Inlet  
(1) 8" Outlet
- \*110-118 to 110-918  
(1) 10" Inlet  
(1) 10" Outlet

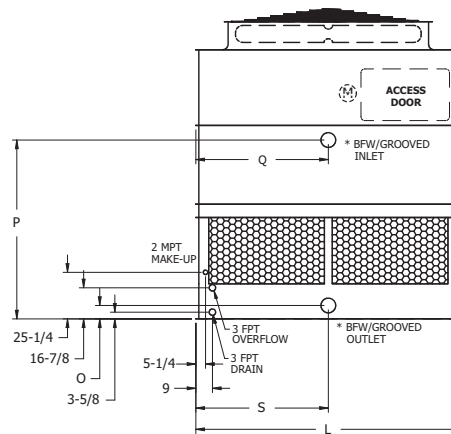
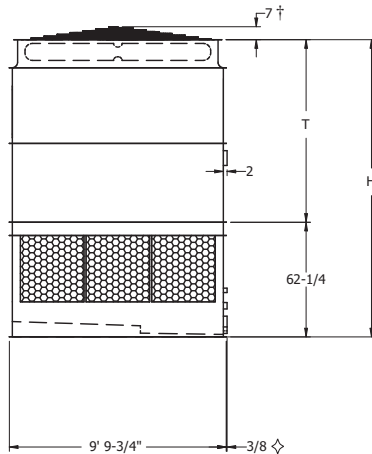
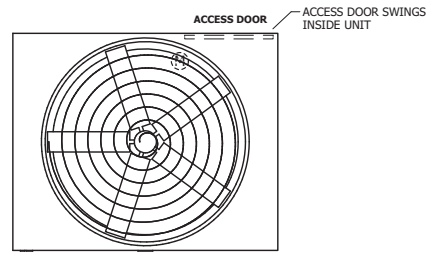

Model No.	Nominal Tonnage	Weights (LBS)			Fan Motor (HP)	Air Flow (CFM)	Dimensions					
		Shipping	Operating	Heaviest Section†			H†	T†	P	O	L	S&Q
AT 110-112L	264	6,840	12,380	4,750	10	63,700	14' 5-1/4"	9' 3"	9' 1"	7-1/4"	11' 11 3/4"	5' 11-7/8"
AT 110-112	309	6,840	12,380	4,750	15	72,300	14' 5-1/4"	9' 3"	9' 1"	7-1/4"	11' 11-3/4"	5' 11-7/8"
AT 110-212L	305	6,410	11,950	4,320	20	80,600	13' 5-1/4"	8' 3"	8' 1"	7-1/4"	11' 11-3/4"	5' 11-7/8"
AT 110-212	326	6,460	12,000	4,370	25	86,500	13' 5-1/4"	8' 3"	8' 1"	7-1/4"	11' 11-3/4"	5' 11-7/8"
AT 110-312	338	6,890	12,430	4,800	20	79,000	14' 5-1/4"	9' 3"	9' 1"	7-1/4"	11' 11-3/4"	5' 11-7/8"
AT 110-412	342	6,560	12,100	4,470	30	91,700	13' 5-1/4"	8' 3"	8' 1"	7-1/4"	11' 11-3/4"	5' 11-7/8"
AT 110-512	361	6,940	12,480	4,850	25	85,000	14' 5-1/4"	9' 3"	9' 1"	7-1/4"	11' 11-3/4"	5' 11-7/8"
AT 110-612L	350	7,310	12,850	5,220	20	77,900	15' 5-1/4"	10' 3"	10' 1"	7-1/4"	11' 11-3/4"	5' 11-7/8"
AT 110-612	373	7,360	12,900	5,270	25	83,700	15' 5-1/4"	10' 3"	10' 1"	7-1/4"	11' 11-3/4"	5' 11-7/8"
AT 110-712	380	7,040	12,580	4,950	30	89,800	14' 5-1/4"	9' 3"	9' 1"	7-1/4"	11' 11-3/4"	5' 11-7/8"
AT 110-812	393	7,460	13,000	5,370	30	88,600	15' 5-1/4"	10' 3"	10' 1"	7-1/4"	11' 11-3/4"	5' 11-7/8"
AT 110-912	410	7,710	13,250	5,620	35	92,800	15' 5-1/4"	10' 3"	10' 1"	7-1/4"	11' 11-3/4"	5' 11-7/8"
UT Addition		✦	700	700			1' 9-1/2"	1' 9-1/2"				
AT 110-118L	351	8,860	17,270	5,710	15	97,800	13' 5-1/4"	8' 3"	8' 0"	8-1/2"	18' 0"	9' 0"
AT 110-118	389	8,910	17,320	5,760	20	107,200	13' 5-1/4"	8' 3"	8' 0"	8-1/2"	18' 0"	9' 0"
AT 110-218L	364	10,180	18,590	7,030	10	83,300	15' 5-1/4"	10' 3"	10' 0"	8-1/2"	18' 0"	9' 0"
AT 110-218	420	10,180	18,590	7,030	15	94,700	15' 5-1/4"	10' 3"	10' 0"	8-1/2"	18' 0"	9' 0"
AT 110-318L	395	9,550	17,960	6,400	15	96,300	14' 5-1/4"	9' 3"	9' 0"	8-1/2"	18' 0"	9' 0"
AT 110-318	437	9,600	18,010	6,450	20	105,500	14' 5-1/4"	9' 3"	9' 0"	8-1/2"	18' 0"	9' 0"
AT 110-418	445	9,060	17,470	5,910	30	122,000	13' 5-1/4"	8' 3"	8' 0"	8-1/2"	18' 0"	9' 0"
AT 110-518	471	9,650	18,060	6,500	25	113,100	14' 5-1/4"	9' 3"	9' 0"	8-1/2"	18' 0"	9' 0"
AT 110-618	499	9,750	18,160	6,600	30	119,700	14' 5-1/4"	9' 3"	9' 0"	8-1/2"	18' 0"	9' 0"
AT 110-718	522	10,380	18,790	7,230	30	117,800	15' 5-1/4"	10' 3"	10' 0"	8-1/2"	18' 0"	9' 0"
AT 110-818	547	10,000	18,410	6,850	40	131,200	14' 5-1/4"	9' 3"	9' 0"	8-1/2"	18' 0"	9' 0"
AT 110-918	570	10,630	19,040	7,480	40	129,000	15' 5-1/4"	10' 3"	10' 0"	8-1/2"	18' 0"	9' 0"
UT Addition		✦	700	700			1' 9-1/2"	1' 9-1/2"				

- NOTE: (1) An adequately sized bleed line must be installed in the cooling tower system to prevent build-up of impurities in the recirculated water.  
 (2) Do not use catalog drawings for certified prints. Dimensions and weights are subject to change.  
 (3) Adequate spacing must be allowed for access to the cooling tower. Refer to EVAPCO's Equipment Layout Manual.  
 (4) Nominal Tonnage is based on 3 gpm per ton at 95 degree entering water temperature, 85 degree leaving water temperature, and 78 degree wet-bulb temperature.

- ✦ Outlet connection extends 3/8" beyond bottom flange.
- † Heaviest section is upper section.
- † Height does not include fan guard. Consult factory for whether or not fan guard ships mounted.
- ✦ Please consult the factory for additional information regarding shipping and section weight changes.

# AT/UT/USS

## ENGINEERING DATA & DIMENSIONS

ONE CELL

### MODELS: AT/UT/USS 112-012 to 112-914

One-Cell Cooling Towers

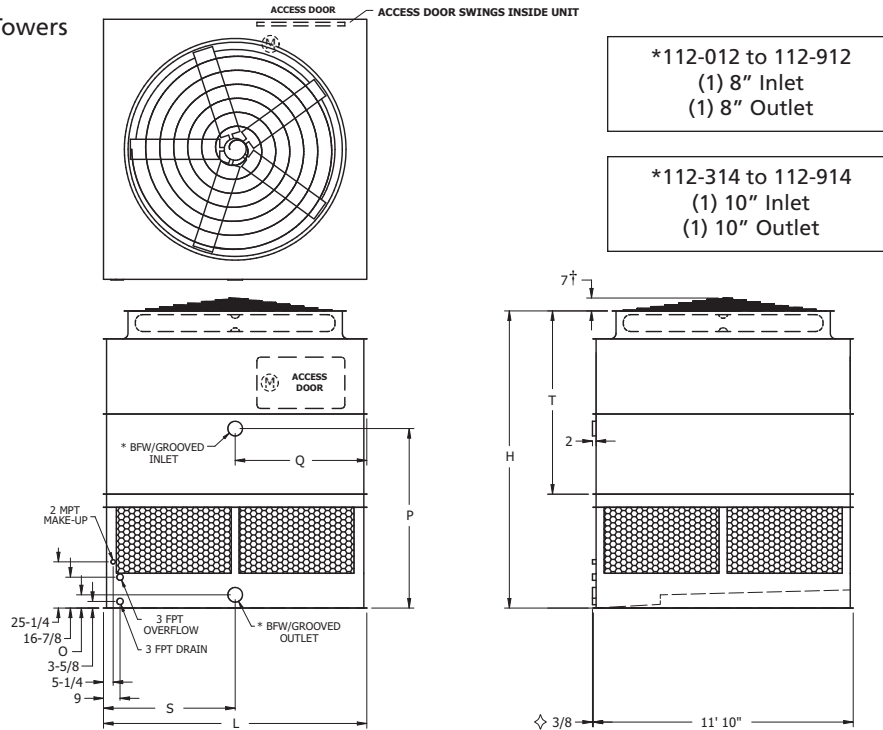

Model No.	Nominal Tonnage	Weights (LBS)			Fan Motor (HP)	Air Flow (CFM)	Dimensions					
		Shipping	Operating	Heaviest Section†			H†	T†	P	O	L	S&Q
AT 112-012L	280	7,370	13,580	4,930	10	71,600	13' 6-1/4"	8' 4"	8' 2"	7-1/4"	11' 11-3/4"	5' 11-7/8"
AT 112-012	334	7,440	13,650	5,000	15	81,400	13' 6-1/4"	8' 4"	8' 2"	7-1/4"	11' 11-3/4"	5' 11-7/8"
AT 112-112	364	7,490	13,700	5,050	20	89,300	13' 6-1/4"	8' 4"	8' 2"	7-1/4"	11' 11-3/4"	5' 11-7/8"
AT 112-212	391	7,540	13,750	5,100	25	95,800	13' 6-1/4"	8' 4"	8' 2"	7-1/4"	11' 11-3/4"	5' 11-7/8"
AT 112-312L	370	7,980	14,190	5,540	15	80,000	14' 6-1/4"	9' 4"	9' 2"	7-1/4"	11' 11-3/4"	5' 11-7/8"
AT 112-312	404	8,030	14,240	5,590	20	87,700	14' 6-1/4"	9' 4"	9' 2"	7-1/4"	11' 11-3/4"	5' 11-7/8"
AT 112-412	414	7,640	13,850	5,200	30	101,500	13' 6-1/4"	8' 4"	8' 2"	7-1/4"	11' 11-3/4"	5' 11-7/8"
AT 112-512L	387	8,470	14,680	6,030	15	78,700	15' 6-1/4"	10' 4"	10' 2"	7-1/4"	11' 11-3/4"	5' 11-7/8"
AT 112-512	422	8,520	14,730	6,080	20	86,300	15' 6-1/4"	10' 4"	10' 2"	7-1/4"	11' 11-3/4"	5' 11-7/8"
AT 112-612	434	8,080	14,290	5,640	25	94,000	14' 6-1/4"	9' 4"	9' 2"	7-1/4"	11' 11-3/4"	5' 11-7/8"
AT 112-712	461	8,180	14,390	5,740	30	99,500	14' 6-1/4"	9' 4"	9' 2"	7-1/4"	11' 11-3/4"	5' 11-7/8"
AT 112-812	481	8,670	14,880	6,230	30	97,900	15' 6-1/4"	10' 4"	10' 2"	7-1/4"	11' 11-3/4"	5' 11-7/8"
AT 112-912	515	8,920	15,130	6,480	40	107,100	15' 6-1/4"	10' 4"	10' 2"	7-1/4"	11' 11-3/4"	5' 11-7/8"
UT Addition		♣	700	700			1' 9-1/2"	1' 9-1/2"				
AT 112-314L	425	8,200	15,530	5,550	25	104,100	14'-1/4"	8' 4"	8' 7"	8-1/2"	13' 11-3/4"	6' 11-7/8"
AT 112-314	450	8,270	15,600	5,620	30	110,400	14'-1/4"	8' 4"	8' 7"	8-1/2"	13' 11-3/4"	6' 11-7/8"
AT 112-414L	439	8,800	16,130	6,150	20	95,400	15'-1/4"	9' 4"	9' 7"	8-1/2"	13' 11-3/4"	6' 11-7/8"
AT 112-414	471	8,860	16,190	6,210	25	102,300	15'-1/4"	9' 4"	9' 7"	8-1/2"	13' 11-3/4"	6' 11-7/8"
AT 112-514L	460	9,320	16,650	6,670	20	93,800	16'-1/4"	10' 4"	10' 7"	8-1/2"	13' 11-3/4"	6' 11-7/8"
AT 112-514	494	9,380	16,710	6,730	25	100,600	16'-1/4"	10' 4"	10' 7"	8-1/2"	13' 11-3/4"	6' 11-7/8"
AT 112-614	501	8,930	16,260	6,280	30	108,300	15'-1/4"	9' 4"	9' 7"	8-1/2"	13' 11-3/4"	6' 11-7/8"
AT 112-714	524	9,450	16,780	6,800	30	106,600	16'-1/4"	10' 4"	10' 7"	8-1/2"	13' 11-3/4"	6' 11-7/8"
AT 112-814	548	9,190	16,520	6,540	40	118,600	15'-1/4"	9' 4"	9' 7"	8-1/2"	13' 11-3/4"	6' 11-7/8"
AT 112-914	574	9,710	17,040	7,060	40	116,600	16'-1/4"	10' 4"	10' 7"	8-1/2"	13' 11-3/4"	6' 11-7/8"
UT Addition		♣	700	700			1' 9-1/2"	1' 9-1/2"				

NOTE: (1) An adequately sized bleed line must be installed in the cooling tower system to prevent build-up of impurities in the recirculated water.  
 (2) Do not use catalog drawings for certified prints. Dimensions and weights are subject to change.  
 (3) Adequate spacing must be allowed for access to the cooling tower. Refer to EVAPCO's Equipment Layout Manual.  
 (4) Nominal Tonnage is based on 3 gpm per ton at 95 degree entering water temperature, 85 degree leaving water temperature, and 78 degree wet-bulb temperature.

- ♠ Outlet connection extends 3/8" beyond bottom flange.
- ♣ Heaviest section is upper section.
- † Height does not include fan guard. Consult factory for whether or not fan guard ships mounted.
- ♣ Please consult the factory for additional information regarding shipping and section weight changes.





# AT/UT/USS

## ENGINEERING DATA & DIMENSIONS

### MODELS: AT/UT/USS 112-018 to 112-920

One-Cell Cooling Towers

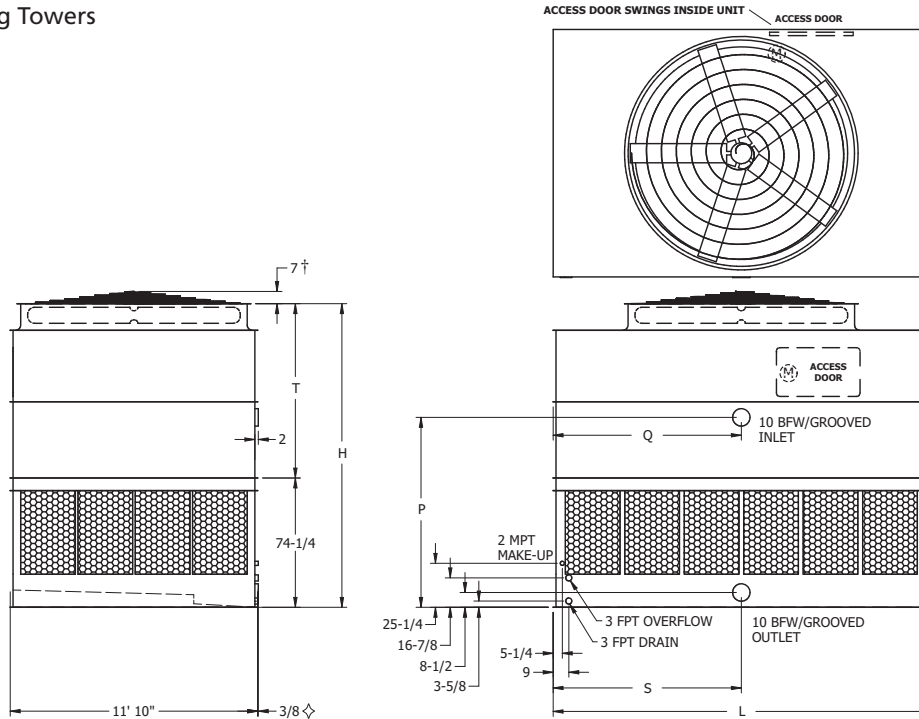

Model No.	Nominal Tonnage	Weights (LBS)			Fan Motor (HP)	Air Flow (CFM)	Dimensions				
		Shipping	Operating	Heaviest Section <sup>†</sup>			H <sup>†</sup>	T <sup>†</sup>	P	L	S&Q
AT 112-018L	497	10,320	19,590	6,760	20	120,600	14' 6 1/4"	8' 4"	9' 1"	18' 0"	9' 0"
AT 112-018	525	10,370	19,640	6,810	25	129,600	14' 6 1/4"	8' 4"	9' 1"	18' 0"	9' 0"
AT 112-118	554	10,480	19,750	6,920	30	137,400	14' 6 1/4"	8' 4"	9' 1"	18' 0"	9' 0"
AT 112-218L	546	11,100	20,370	7,540	20	118,700	15' 6 1/4"	9' 4"	10' 1"	18' 0"	9' 0"
AT 112-218	581	11,150	20,420	7,590	25	127,400	15' 6 1/4"	9' 4"	10' 1"	18' 0"	9' 0"
AT 112-318	614	11,260	20,530	7,700	30	135,000	15' 6 1/4"	9' 4"	10' 1"	18' 0"	9' 0"
AT 112-418L	606	11,890	21,160	8,330	25	125,400	16' 6 1/4"	10' 4"	11' 1"	18' 0"	9' 0"
AT 112-418	642	12,000	21,270	8,440	30	132,900	16' 6 1/4"	10' 4"	11' 1"	18' 0"	9' 0"
AT 112-518	675	11,520	20,790	7,960	40	147,700	15' 6 1/4"	9' 4"	10' 1"	18' 0"	9' 0"
AT 112-618	705	12,260	21,530	8,700	40	145,300	16' 6 1/4"	10' 4"	11' 1"	18' 0"	9' 0"
AT 112-718	724	11,580	20,850	8,020	50	158,500	15' 6 1/4"	9' 4"	10' 1"	18' 0"	9' 0"
AT 112-818	757	12,320	21,590	8,760	50	155,600	16' 6 1/4"	10' 4"	11' 1"	18' 0"	9' 0"
AT 112-918	785	12,430	21,700	8,870	60	165,000	16' 6 1/4"	10' 4"	11' 1"	18' 0"	9' 0"
UT Addition		✦	1,200	1,200			1' 3-1/2"	1' 3-1/2"			
AT 112-520L	625	11,440	21,840	7,630	40	154,100	14' 6 1/4"	8' 4"	9' 1"	20' 0"	10' 0"
AT 112-520	679	11,500	21,900	7,690	50	165,300	14' 6 1/4"	8' 4"	9' 1"	20' 0"	10' 0"
AT 112-620L	655	12,810	23,210	9,000	30	136,100	16' 6 1/4"	10' 4"	11' 1"	20' 0"	10' 0"
AT 112-620	728	13,070	23,470	9,260	40	148,800	16' 6 1/4"	10' 4"	11' 1"	20' 0"	10' 0"
AT 112-720L	698	12,170	22,570	8,360	40	151,200	15' 6 1/4"	9' 4"	10' 1"	20' 0"	10' 0"
AT 112-720	757	12,230	22,630	8,420	50	162,200	15' 6 1/4"	9' 4"	10' 1"	20' 0"	10' 0"
AT 112-820	788	13,130	23,530	9,320	50	159,500	16' 6 1/4"	10' 4"	11' 1"	20' 0"	10' 0"
AT 112-920	817	13,240	23,640	9,430	60	169,100	16' 6 1/4"	10' 4"	11' 1"	20' 0"	10' 0"
UT Addition		✦	1,200	1,200			1' 3-1/2"	1' 3-1/2"			

NOTE: (1) An adequately sized bleed line must be installed in the cooling tower system to prevent build-up of impurities in the recirculated water.  
 (2) Do not use catalog drawings for certified prints. Dimensions and weights are subject to change.  
 (3) Adequate spacing must be allowed for access to the cooling tower. Refer to EVAPCO's Equipment Layout Manual.  
 (4) Nominal Tonnage is based on 3 gpm per ton at 95 degree entering water temperature, 85 degree leaving water temperature, and 78 degree wet-bulb temperature.

- ◇ Outlet connection extends 3/8" beyond bottom flange.
- ✦ Heaviest section is upper section.
- † Height does not include fan guard. Consult factory for whether or not fan guard ships mounted.
- ♣ Please consult the factory for additional information regarding shipping and section weight changes.



## ENGINEERING DATA & DIMENSIONS

ONE CELL

### MODELS: AT/UT/USS 114-0124 to 114-1324

One-Cell Cooling Towers

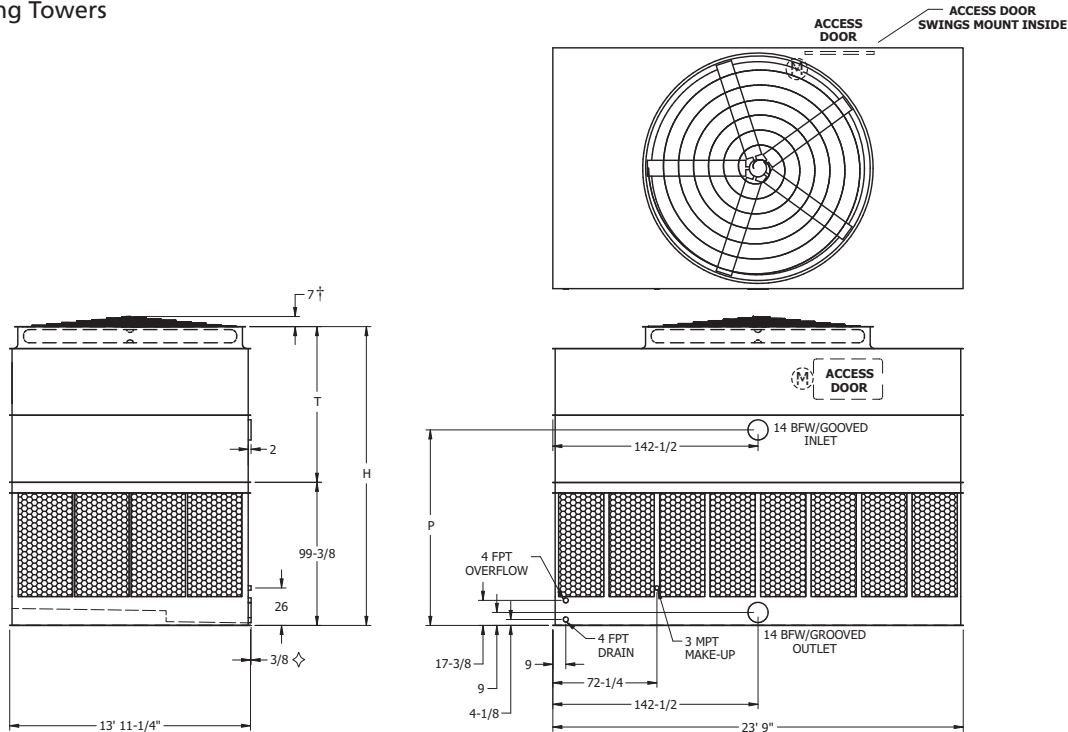

Model No.	Nominal Tonnage	Weights (LBS)			Fan Motor (HP)	Air Flow (CFM)	Dimensions		
		Shipping	Operating	Heaviest Section <sup>†</sup>			H <sup>†</sup>	T <sup>†</sup>	P
AT 114-0124L	684	16,490	32,340	10,650	25	170,100	17' 5-5/8"	9' 2-1/4"	11' 3-7/8"
AT 114-0124	722	16,510	32,360	10,670	30	180,300	17' 5-5/8"	9' 2-1/4"	11' 3-7/8"
AT 114-0224	781	16,660	32,510	10,820	40	197,600	17' 5-5/8"	9' 2-1/4"	11' 3-7/8"
AT 114-0324L	772	18,520	34,370	12,680	25	152,100	19' 5-5/8"	11' 2-1/4"	13' 3-7/8"
AT 114-0324	834	18,570	34,420	12,730	25	163,200	19' 5-5/8"	11' 2-1/4"	13' 3-7/8"
AT 114-0424	839	17,010	32,860	11,170	50	212,300	17' 5-5/8"	9' 2-1/4"	11' 3-7/8"
AT 114-0524	872	18,590	34,440	12,750	30	173,400	19' 5-5/8"	11' 2-1/4"	13' 3-7/8"
AT 114-0624L	812	17,550	33,400	11,710	30	177,400	18' 5-5/8"	10' 2-1/4"	12' 3-7/8"
AT 114-0624	892	17,700	33,550	11,860	40	194,100	18' 5-5/8"	10' 2-1/4"	12' 3-7/8"
AT 114-0724	947	18,740	34,590	12,900	40	190,900	19' 5-5/8"	11' 2-1/4"	13' 3-7/8"
AT 114-0824	951	18,050	33,900	12,210	50	208,500	18' 5-5/8"	10' 2-1/4"	12' 3-7/8"
AT 114-0924	998	19,090	34,940	13,250	50	205,000	19' 5-5/8"	11' 2-1/4"	13' 3-7/8"
AT 114-1024	1,008	18,220	34,070	12,380	60	220,600	18' 5-5/8"	10' 2-1/4"	12' 3-7/8"
AT 114-1124	1,056	19,260	35,110	13,420	60	217,100	19' 5-5/8"	11' 2-1/4"	13' 3-7/8"
AT 114-1224	1,135	19,500	35,350	13,660	75	238,000	19' 5-5/8"	11' 2-1/4"	13' 3-7/8"
AT 114-1324**	1,201	19,940	35,790	14,100	100	255,100	19' 5-5/8"	11' 2-1/4"	13' 3-7/8"
UT Addition		✦	1,250	1,250			1' 1-1/2"	1' 1-1/2"	

NOTE: (1) An adequately sized bleed line must be installed in the cooling tower system to prevent build-up of impurities in the recirculated water.  
 (2) Do not use catalog drawings for certified prints. Dimensions and weights are subject to change.  
 (3) Adequate spacing must be allowed for access to the cooling tower. Refer to EVAPCO's Equipment Layout Manual.  
 (4) Nominal Tonnage is based on 3 gpm per ton at 95 degree entering water temperature, 85 degree leaving water temperature, and 78 degree wet-bulb temperature.

- ✦ Outlet connection extends 3/8" beyond bottom flange.
- ✦ Heaviest section is upper section.
- † Height does not include fan guard. Consult factory for whether or not fan guard ships mounted.
- ✦ Please consult the factory for additional information regarding shipping and section weight changes.

\*\* Model available with gear drive only. Motor and access door located on 13' 11-1/4" unit end. Super Low Sound Fan is not available on this unit.



# AT/UT/USS

## ENGINEERING DATA & DIMENSIONS

### MODELS: AT/UT/USS 114-526 to 114-926

One-Cell Cooling Towers

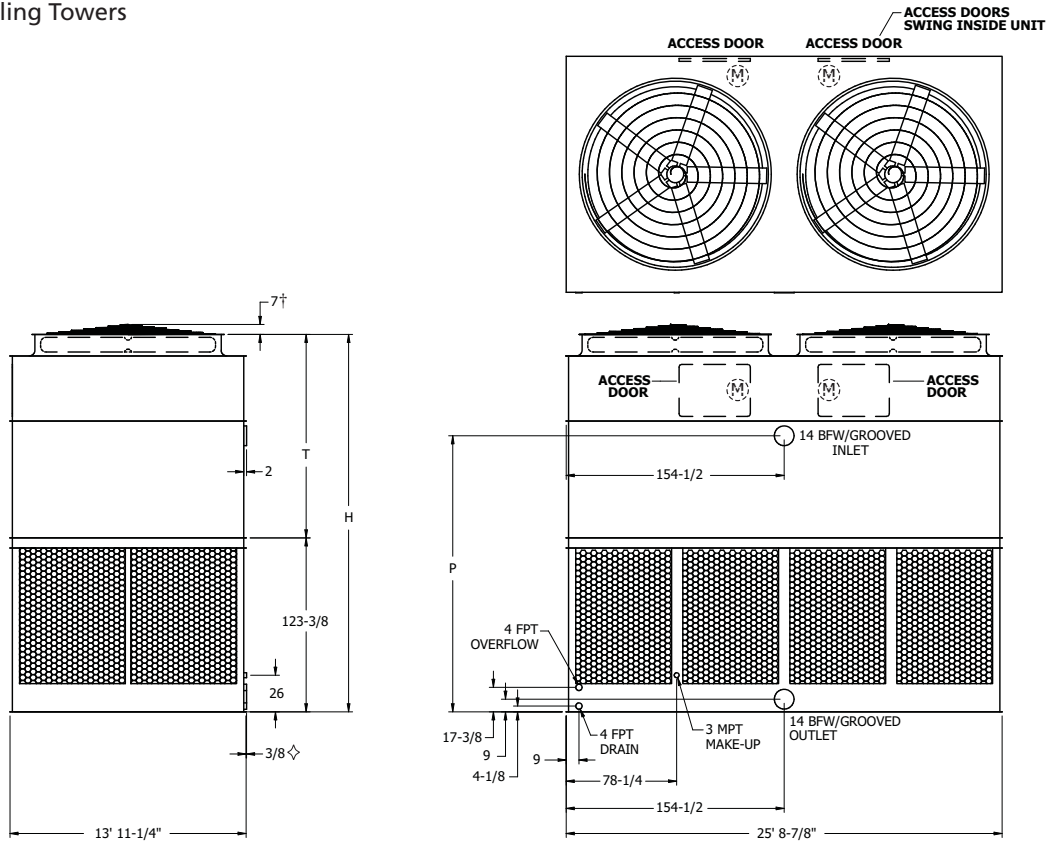

Model No.	Nominal Tonnage	Weights (LBS)			Fan Motor (HP)	Air Flow (CFM)	Dimensions		
		Shipping	Operating	Heaviest Section†			H†	T†	P
AT 114-526	1,003	24,800	41,630	17,660	(2)20	200,200	22' 3-1/2"	12' 1/8"	16' 3-3/4"
AT 114-626	1,078	24,860	41,690	17,720	(2)25	214,700	22' 3-1/2"	12' 1/8"	16' 3-3/4"
AT 114-726	1,142	24,960	41,790	17,820	(2)30	227,300	22' 3-1/2"	12' 1/8"	16' 3-3/4"
AT 114-826	1,247	25,280	42,110	18,140	(2)40	248,500	22' 3-1/2"	12' 1/8"	16' 3-3/4"
AT 114-926	1,332	25,300	42,130	18,160	(2)50	266,300	22' 3-1/2"	12' 1/8"	16' 3-3/4"
UT Addition		✦	2,400	✦			1' 3-1/2"	1' 3-1/2"	

- NOTE: (1) An adequately sized bleed line must be installed in the cooling tower system to prevent build-up of impurities in the recirculated water.  
 (2) Do not use catalog drawings for certified prints. Dimensions and weights are subject to change.  
 (3) Adequate spacing must be allowed for access to the cooling tower. Refer to EVAPCO's Equipment Layout Manual.  
 (4) Nominal Tonnage is based on 3 gpm per ton at 95 degree entering water temperature, 85 degree leaving water temperature, and 78 degree wet-bulb temperature.

- ◇ Outlet connection extends 3/8" beyond bottom flange.
- ✦ Heaviest section is upper section.
- † Height does not include fan guard. Consult factory for whether or not fan guard ships mounted.
- ✦ Please consult the factory for additional information regarding shipping and section weight changes.

## ENGINEERING DATA & DIMENSIONS

### MODELS: AT/UT/USS 26-517 to 28-917

Two-Cell Cooling Towers

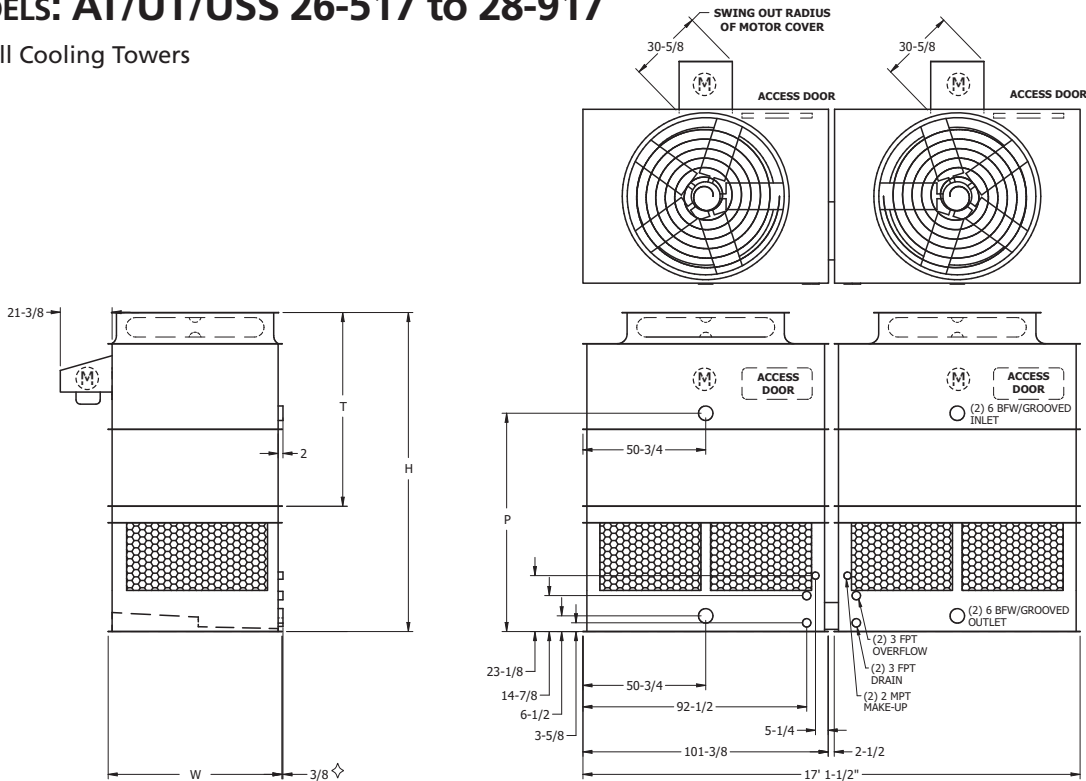

Model No.	Nominal Tonnage	Weights (LBS)			Fan Motor (HP)	Air Flow (CFM)	Dimensions			
		Shipping	Operating	Heaviest Section <sup>†</sup>			H <sup>†</sup>	T <sup>†</sup>	P	W
AT 26-517L	179	6,080	10,160	1,990	(2)3	45,200	10' 11-7/8"	6' 8"	7' 6"	5' 11-7/8"
AT 26-517	225	6,120	10,200	2,010	(2)5	53,100	10' 11-7/8"	6' 8"	7' 6"	5' 11-7/8"
AT 26-617	247	6,200	10,280	2,050	(2)7.5	60,500	10' 11-7/8"	6' 8"	7' 6"	5' 11-7/8"
AT 26-717L	250	6,520	10,600	2,210	(2)5	52,300	11' 11-7/8"	7' 8"	8' 6"	5' 11-7/8"
AT 26-717	277	6,600	10,680	2,250	(2)7.5	59,400	11' 11-7/8"	7' 8"	8' 6"	5' 11-7/8"
AT 26-817	302	6,660	10,740	2,280	(2)10	65,100	11' 11-7/8"	7' 8"	8' 6"	5' 11-7/8"
AT 26-917L	315	7,100	11,180	2,500	(2)10	64,000	12' 11-7/8"	8' 8"	9' 6"	5' 11-7/8"
AT 26-917	344	7,240	11,320	2,570	(2)15	72,800	12' 11-7/8"	8' 8"	9' 6"	5' 11-7/8"
UT Addition		✦	300	150			1' 1"	1' 1"		
AT 28-217L	217	6,860	11,700	2,260	(2)3	53,200	11' 4-1/4"	6' 8"	7' 10-1/2"	7' 5-7/8"
AT 28-217	274	6,900	11,740	2,280	(2)5	62,600	11' 4-1/4"	6' 8"	7' 10-1/2"	7' 5-7/8"
AT 28-317	297	6,980	11,820	2,320	(2)7.5	71,400	11' 4-1/4"	6' 8"	7' 10-1/2"	7' 5-7/8"
AT 28-417	319	7,040	11,880	2,350	(2)10	78,300	11' 4-1/4"	6' 8"	7' 10-1/2"	7' 5-7/8"
AT 28-517L	304	7,360	12,200	2,510	(2)5	61,600	12' 4-1/4"	7' 8"	8' 10-1/2"	7' 5-7/8"
AT 28-517	331	7,440	12,280	2,550	(2)7.5	70,200	12' 4-1/4"	7' 8"	8' 10-1/2"	7' 5-7/8"
AT 28-617	358	7,500	12,340	2,580	(2)10	76,900	12' 4-1/4"	7' 8"	8' 10-1/2"	7' 5-7/8"
AT 28-717L	346	7,980	12,820	2,820	(2)7.5	69,100	13' 4-1/4"	8' 8"	9' 10-1/2"	7' 5-7/8"
AT 28-717	373	8,040	12,880	2,850	(2)10	75,700	13' 4-1/4"	8' 8"	9' 10-1/2"	7' 5-7/8"
AT 28-817	393	7,620	12,460	2,640	(2)15	87,500	12' 4-1/4"	7' 8"	8' 10-1/2"	7' 5-7/8"
AT 28-917	414	8,160	13,000	2,910	(2)15	86,000	13' 4-1/4"	8' 8"	9' 10-1/2"	7' 5-7/8"
UT Addition		✦	300	150			1' 5"	1' 5"		

NOTE: (1) An adequately sized bleed line must be installed in the cooling tower system to prevent build-up of impurities in the recirculated water.  
 (2) Do not use catalog drawings for certified prints. Dimensions and weights are subject to change.  
 (3) Adequate spacing must be allowed for access to the cooling tower. Refer to EVAPCO's Equipment Layout Manual.  
 (4) These models are available as (2) independent operating cells. Consult the factory for details.  
 (5) Nominal Tonnage is based on 3 gpm per ton at 95 degree entering water temperature, 85 degree leaving water temperature, and 78 degree wet-bulb temperature.

- ✦ Outlet connection extends 3/8" beyond bottom flange.
- † Heaviest section is upper section.
- † Height includes fan guard which ships factory mounted.
- ✦ Please consult the factory for additional information regarding shipping and section weight changes.

TWO CELL





# AT/UT/USS

## ENGINEERING DATA & DIMENSIONS

### MODELS: AT/UT/USS 29-318 to 29-921

Two-Cell Cooling Towers

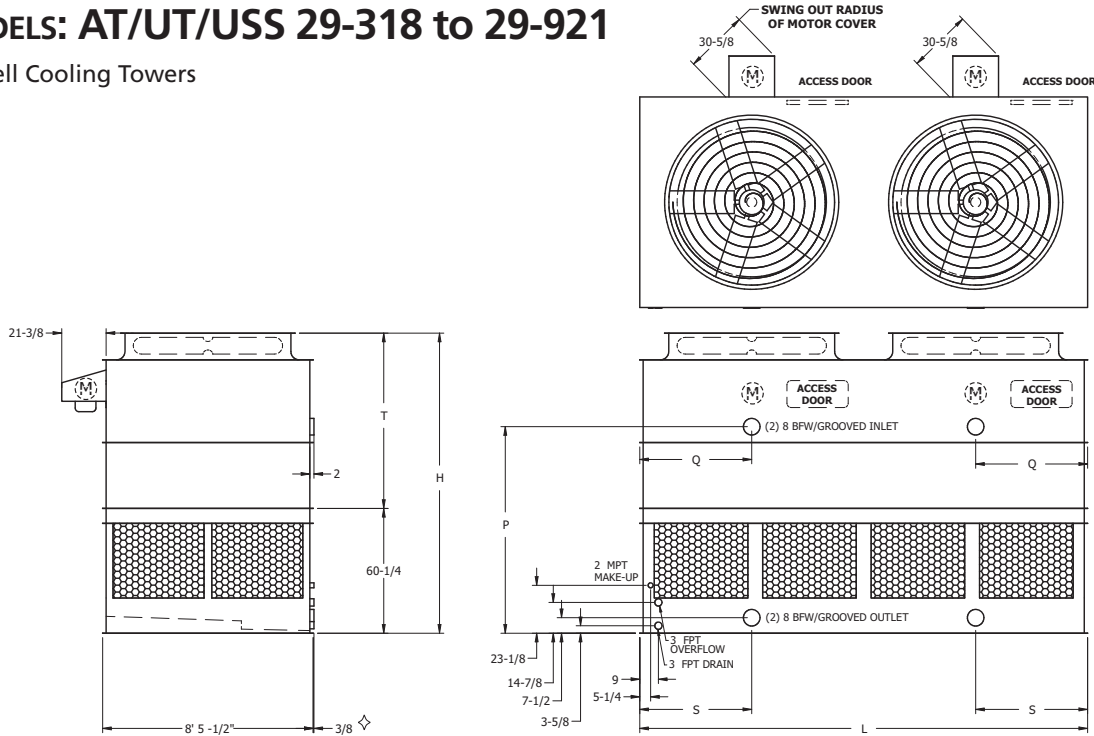

Model No.	Nominal Tonnage	Weights (LBS)			Fan Motor (HP)	Air Flow (CFM)	Dimensions				
		Shipping	Operating	Heaviest Section <sup>♦</sup>			H <sup>†</sup>	T <sup>†</sup>	P	L	S&Q
AT 29-318L	274	7,840	13,730	5,290	(2) 5	72,000	12' 3/4"	7' 1/2"	8' 3-1/2"	18' 0"	4' 5-3/4"
AT 29-318	329	7,920	13,810	5,370	(2) 7.5	81,900	12' 3/4"	7' 1/2"	8' 3-1/2"	18' 0"	4' 5-3/4"
AT 29-418	362	7,980	13,870	5,430	(2) 10	89,800	12' 3/4"	7' 1/2"	8' 3-1/2"	18' 0"	4' 5-3/4"
AT 29-518L	368	8,450	14,340	5,900	(2) 7.5	80,600	13' 3/4"	8' 1/2"	9' 3-1/2"	18' 0"	4' 5-3/4"
AT 29-518	404	8,510	14,400	5,960	(2) 10	88,200	13' 3/4"	8' 1/2"	9' 3-1/2"	18' 0"	4' 5-3/4"
AT 29-618	422	8,120	14,010	5,570	(2) 15	102,000	12' 3/4"	7' 1/2"	8' 3-1/2"	18' 0"	4' 5-3/4"
AT 29-718	471	8,650	14,540	6,100	(2) 15	100,100	13' 3/4"	8' 1/2"	9' 3-1/2"	18' 0"	4' 5-3/4"
AT 29-818L	425	9,090	14,980	6,540	(2) 10	86,800	14' 3/4"	9' 1/2"	10' 3-1/2"	18' 0"	4' 5-3/4"
AT 29-818	491	9,230	15,120	6,680	(2) 15	98,400	14' 3/4"	9' 1/2"	10' 3-1/2"	18' 0"	4' 5-3/4"
AT 29-918	538	9,330	15,220	6,780	(2) 20	107,600	14' 3/4"	9' 1/2"	10' 3-1/2"	18' 0"	4' 5-3/4"
UT Addition		✦	300	300			1' 9"	1' 9"			
AT 29-121L	315	8,920	15,860	6,130	(2) 5	80,700	12' 3/4"	7' 1/2"	8' 3-1/2"	21' 0"	5' 2-3/4"
AT 29-121	379	9,000	15,940	6,210	(2) 7.5	91,800	12' 3/4"	7' 1/2"	8' 3-1/2"	21' 0"	5' 2-3/4"
AT 29-221L	347	9,530	16,470	6,740	(2) 5	79,600	13' 3/4"	8' 1/2"	9' 3-1/2"	21' 0"	5' 2-3/4"
AT 29-221	410	9,610	16,550	6,820	(2) 7.5	90,500	13' 3/4"	8' 1/2"	9' 3-1/2"	21' 0"	5' 2-3/4"
AT 29-321	448	9,670	16,610	6,880	(2) 10	99,200	13' 3/4"	8' 1/2"	9' 3-1/2"	21' 0"	5' 2-3/4"
AT 29-421	467	9,200	16,140	6,410	(2) 15	114,600	12' 3/4"	7' 1/2"	8' 3-1/2"	21' 0"	5' 2-3/4"
AT 29-521L	445	10,270	17,210	7,480	(2) 7.5	88,900	14' 3/4"	9' 1/2"	10' 3-1/2"	21' 0"	5' 2-3/4"
AT 29-521	482	10,330	17,270	7,540	(2) 10	97,500	14' 3/4"	9' 1/2"	10' 3-1/2"	21' 0"	5' 2-3/4"
AT 29-621	518	9,810	16,750	7,020	(2) 15	112,500	13' 3/4"	8' 1/2"	9' 3-1/2"	21' 0"	5' 2-3/4"
AT 29-721	547	10,470	17,410	7,680	(2) 15	110,700	14' 3/4"	9' 1/2"	10' 3-1/2"	21' 0"	5' 2-3/4"
AT 29-821	578	9,910	16,850	7,120	(2) 20	123,000	13' 3/4"	8' 1/2"	9' 3-1/2"	21' 0"	5' 2-3/4"
AT 29-921	636	10,630	17,570	7,840	(2) 25	129,800	14' 3/4"	9' 1/2"	10' 3-1/2"	21' 0"	5' 2-3/4"
UT Addition		✦	300	300			1' 9"	1' 9"			

- NOTE: (1) An adequately sized bleed line must be installed in the cooling tower system to prevent build-up of impurities in the recirculated water.  
 (2) Do not use catalog drawings for certified prints. Dimensions and weights are subject to change.  
 (3) Adequate spacing must be allowed for access to the cooling tower. Refer to EVAPCO's Equipment Layout Manual.  
 (4) These models are available as (2) independent operating cells. Consult the factory for details.  
 (5) Nominal Tonnage is based on 3 gpm per ton at 95 degree entering water temperature, 85 degree leaving water temperature, and 78 degree wet-bulb temperature.

- ✦ Outlet connection extends 3/8" beyond bottom flange.
- ♦ Heaviest section is upper section.
- † Height includes fan guard which ships factory mounted.
- ✦ Please consult the factory for additional information regarding shipping and section weight changes.

# AT/UT/USS

## ENGINEERING DATA & DIMENSIONS

### MODELS: AT/UT/USS 29-024 to 29-928

Two-Cell Cooling Towers

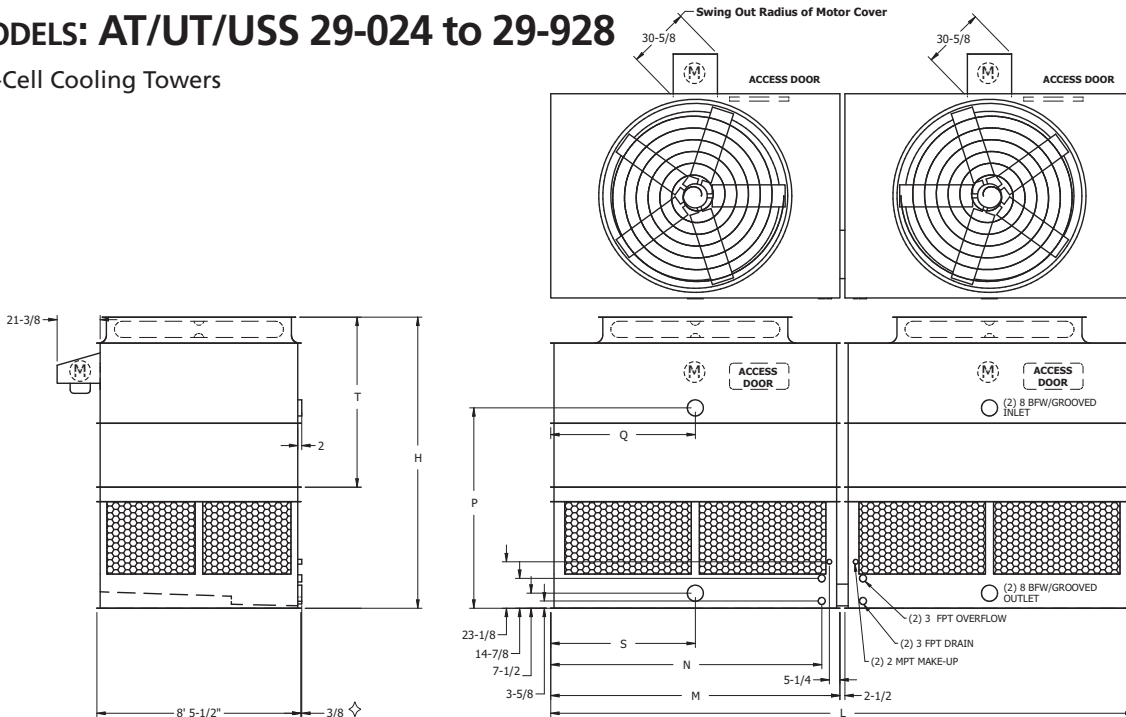

Model No.	Nominal Tonnage	Weights (LBS)			Fan Motor (HP)	Air Flow (CFM)	Dimensions						
		Shipping	Operating	Heaviest Section†			H†	T†	P	L	M	N	S&Q
AT 29-024L	452	10,860	18,580	3,790	(2) 7.5	98,600	13' 3/4"	8' 1/2"	9' 3-1/2"	24' 2"	11' 11-3/4"	11' 2-3/4"	5' 11-7/8"
AT 29-024	506	10,920	18,640	3,820	(2) 10	107,900	13' 3/4"	8' 1/2"	9' 3-1/2"	24' 2"	11' 11-3/4"	11' 2-3/4"	5' 11-7/8"
AT 29-124L	481	11,640	19,360	4,180	(2) 7.5	96,900	14' 3/4"	9' 1/2"	10' 3-1/2"	24' 2"	11' 11-3/4"	11' 2-3/4"	5' 11-7/8"
AT 29-124	531	11,700	19,420	4,210	(2) 10	106,200	14' 3/4"	9' 1/2"	10' 3-1/2"	24' 2"	11' 11-3/4"	11' 2-3/4"	5' 11-7/8"
AT 29-224L	507	10,360	18,080	3,540	(2) 15	124,900	12' 3/4"	7' 1/2"	8' 3-1/2"	24' 2"	11' 11-3/4"	11' 2-3/4"	5' 11-7/8"
AT 29-224	559	10,440	18,160	3,580	(2) 20	137,000	12' 3/4"	7' 1/2"	8' 3-1/2"	24' 2"	11' 11-3/4"	11' 2-3/4"	5' 11-7/8"
AT 29-324	571	11,080	18,800	3,900	(2) 15	122,600	13' 3/4"	8' 1/2"	9' 3-1/2"	24' 2"	11' 11-3/4"	11' 2-3/4"	5' 11-7/8"
AT 29-424	593	11,860	19,580	4,290	(2) 15	120,700	14' 3/4"	9' 1/2"	10' 3-1/2"	24' 2"	11' 11-3/4"	11' 2-3/4"	5' 11-7/8"
AT 29-524	630	11,160	18,880	3,940	(2) 20	134,100	13' 3/4"	8' 1/2"	9' 3-1/2"	24' 2"	11' 11-3/4"	11' 2-3/4"	5' 11-7/8"
AT 29-624	653	11,940	19,660	4,330	(2) 20	132,100	14' 3/4"	9' 1/2"	10' 3-1/2"	24' 2"	11' 11-3/4"	11' 2-3/4"	5' 11-7/8"
AT 29-724	674	11,200	18,920	3,960	(2) 25	144,000	13' 3/4"	8' 1/2"	9' 3-1/2"	24' 2"	11' 11-3/4"	11' 2-3/4"	5' 11-7/8"
AT 29-824	696	11,980	19,700	4,350	(2) 25	141,600	14' 3/4"	9' 1/2"	10' 3-1/2"	24' 2"	11' 11-3/4"	11' 2-3/4"	5' 11-7/8"
AT 29-924	718	12,020	19,740	4,370	(2) 30	150,100	14' 3/4"	9' 1/2"	10' 3-1/2"	24' 2"	11' 11-3/4"	11' 2-3/4"	5' 11-7/8"
UT Addition		*	300	150			1' 9"	1' 9"					
AT 29-228L	563	12,020	21,040	4,120	(2) 10	121,100	13' 6-3/4"	8' 1/2"	9' 9-1/2"	28' 2"	13' 11-3/4"	13' 2-3/4"	6' 11-7/8"
AT 29-228	633	12,180	21,200	4,200	(2) 15	137,800	13' 6-3/4"	8' 1/2"	9' 9-1/2"	28' 2"	13' 11-3/4"	13' 2-3/4"	5' 11-7/8"
AT 29-328L	622	11,440	20,460	3,830	(2) 20	153,600	12' 6-3/4"	7' 1/2"	8' 9-1/2"	28' 2"	13' 11-3/4"	13' 2-3/4"	5' 11-7/8"
AT 29-328	678	11,480	20,500	3,850	(2) 25	164,700	12' 6-3/4"	7' 1/2"	8' 9-1/2"	28' 2"	13' 11-3/4"	13' 2-3/4"	5' 11-7/8"
AT 29-428	698	12,260	21,280	4,240	(2) 20	150,600	13' 6-3/4"	8' 1/2"	9' 9-1/2"	28' 2"	13' 11-3/4"	13' 2-3/4"	5' 11-7/8"
AT 29-528L	661	13,080	22,100	4,650	(2) 15	135,600	14' 6-3/4"	9' 1/2"	10' 9-1/2"	28' 2"	13' 11-3/4"	13' 2-3/4"	5' 11-7/8"
AT 29-528	726	13,160	22,180	4,690	(2) 20	148,300	14' 6-3/4"	9' 1/2"	10' 9-1/2"	28' 2"	13' 11-3/4"	13' 2-3/4"	5' 11-7/8"
AT 29-628	757	12,300	21,320	4,260	(2) 25	161,600	13' 6-3/4"	8' 1/2"	9' 9-1/2"	28' 2"	13' 11-3/4"	13' 2-3/4"	5' 11-7/8"
AT 29-728	787	13,200	22,220	4,710	(2) 25	159,000	14' 6-3/4"	9' 1/2"	10' 9-1/2"	28' 2"	13' 11-3/4"	13' 2-3/4"	5' 11-7/8"
AT 29-828	802	12,340	21,360	4,280	(2) 30	171,200	13' 6-3/4"	8' 1/2"	9' 9-1/2"	28' 2"	13' 11-3/4"	13' 2-3/4"	5' 11-7/8"
AT 29-928	830	13,240	22,260	4,730	(2) 30	168,200	14' 6-3/4"	9' 1/2"	10' 9-1/2"	28' 2"	13' 11-3/4"	13' 2-3/4"	5' 11-7/8"
UT Addition		*	300	150			1' 9"	1' 9"					

- NOTE: (1) An adequately sized bleed line must be installed in the cooling tower system to prevent build-up of impurities in the recirculated water.  
 (2) Do not use catalog drawings for certified prints. Dimensions and weights are subject to change.  
 (3) Adequate spacing must be allowed for access to the cooling tower. Refer to EVAPCO's Equipment Layout Manual.  
 (4) These models are available as (2) independent operating cells. Consult the factory for details.  
 (5) Nominal Tonnage is based on 3 gpm per ton at 95 degree entering water temperature, 85 degree leaving water temperature, and 78 degree wet-bulb temperature.

- ◇ Outlet connection extends 3/8" beyond bottom flange.
- ♣ Heaviest section is upper section.
- † Height includes fan guard which ships factory mounted.
- ♣ Please consult the factory for additional information regarding shipping and section weight changes.

TWO CELL





# AT/UT/USS

## ENGINEERING DATA & DIMENSIONS

### MODELS: AT/UT/USS 210-124 to 210-936

Two-Cell Cooling Towers

\*210-124 to 210-924  
(2) 8" Inlet  
(2) 8" Outlet

\*210-136 to 210-936  
(2) 10" Inlet  
(2) 10" Outlet

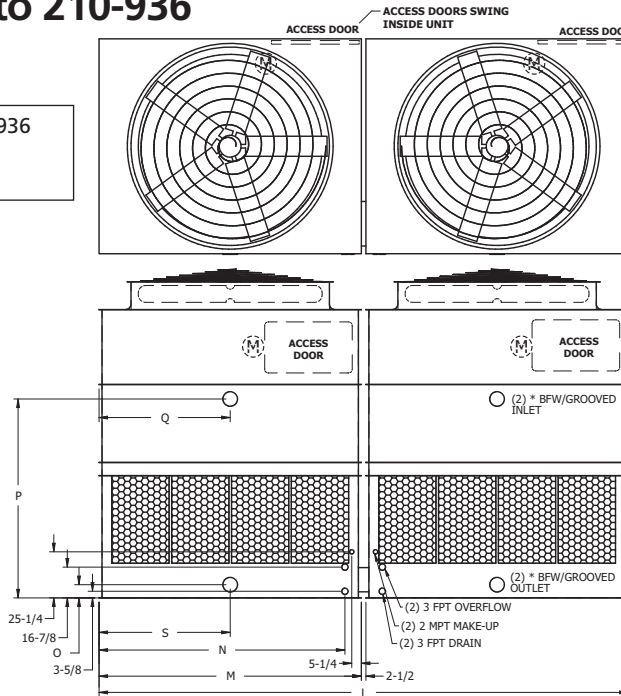
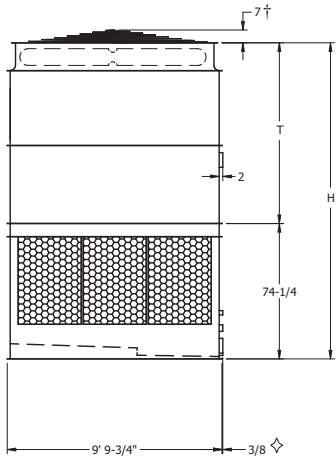

Model No.	Nominal Tonnage	Weights (LBS)			Fan Motor (HP)	Air Flow (CFM)	Dimensions							
		Shipping	Operating	Heaviest Section <sup>†</sup>			H <sup>†</sup>	T <sup>†</sup>	P	O	L	M	N	S&Q
AT 210-124L	529	13,860	24,940	4,750	(2) 10	127,300	15' 5-1/4"	9' 3"	10' 1"	7-1/4"	24' 2"	11' 11-3/4"	11' 2-3/4"	5' 11-7/8"
AT 210-124	618	13,860	24,940	4,750	(2) 15	144,500	15' 5-1/4"	9' 3"	10' 1"	7-1/4"	24' 2"	11' 11-3/4"	11' 2-3/4"	5' 11-7/8"
AT 210-224L	611	13,000	24,080	4,320	(2) 20	161,100	14' 5-1/4"	8' 3"	9' 1"	7-1/4"	24' 2"	11' 11-3/4"	11' 2-3/4"	5' 11-7/8"
AT 210-224	651	13,100	24,180	4,370	(2) 25	172,900	14' 5-1/4"	8' 3"	9' 1"	7-1/4"	24' 2"	11' 11-3/4"	11' 2-3/4"	5' 11-7/8"
AT 210-324	676	13,960	25,040	4,800	(2) 20	158,300	15' 5-1/4"	9' 3"	10' 1"	7-1/4"	24' 2"	11' 11-3/4"	11' 2-3/4"	5' 11-7/8"
AT 210-424	684	13,300	24,380	4,470	(2) 30	183,500	14' 5-1/4"	8' 3"	9' 1"	7-1/4"	24' 2"	11' 11-3/4"	11' 2-3/4"	5' 11-7/8"
AT 210-524	722	14,060	25,140	4,850	(2) 25	169,700	15' 5-1/4"	9' 3"	10' 1"	7-1/4"	24' 2"	11' 11-3/4"	11' 2-3/4"	5' 11-7/8"
AT 210-624L	701	14,800	25,880	5,220	(2) 20	155,800	16' 5-1/4"	10' 3"	11' 1"	7-1/4"	24' 2"	11' 11-3/4"	11' 2-3/4"	5' 11-7/8"
AT 210-624	746	14,900	25,980	5,270	(2) 25	167,200	16' 5-1/4"	10' 3"	11' 1"	7-1/4"	24' 2"	11' 11-3/4"	11' 2-3/4"	5' 11-7/8"
AT 210-724	760	14,260	25,340	4,950	(2) 30	179,900	15' 5-1/4"	9' 3"	10' 1"	7-1/4"	24' 2"	11' 11-3/4"	11' 2-3/4"	5' 11-7/8"
AT 210-824	785	15,100	26,180	5,370	(2) 30	176,900	16' 5-1/4"	10' 3"	11' 1"	7-1/4"	24' 2"	11' 11-3/4"	11' 2-3/4"	5' 11-7/8"
AT 210-924	820	15,600	26,680	5,620	(2) 35	185,600	16' 5-1/4"	10' 3"	11' 1"	7-1/4"	24' 2"	11' 11-3/4"	11' 2-3/4"	5' 11-7/8"
UT Addition		✦	1,400	700			1' 9-1/2"	1' 9-1/2"						
AT 210-136L	701	18,100	34,910	5,710	(2) 15	195,600	14' 5-1/4"	8' 3"	9' 0"	8-1/2"	36' 2-1/2"	11' 2-3/4"	13' 2-3/4"	9' 0"
AT 210-136	779	18,200	35,010	5,760	(2) 20	214,400	14' 5-1/4"	8' 3"	9' 0"	8-1/2"	36' 2-1/2"	11' 2-3/4"	13' 2-3/4"	9' 0"
AT 210-236L	727	20,600	37,410	6,960	(2) 10	166,500	16' 5-1/4"	10' 3"	11' 0"	8-1/2"	36' 2-1/2"	11' 2-3/4"	13' 2-3/4"	9' 0"
AT 210-236	839	20,740	37,550	7,030	(2) 15	189,400	16' 5-1/4"	10' 3"	11' 0"	8-1/2"	36' 2-1/2"	11' 2-3/4"	13' 2-3/4"	9' 0"
AT 210-336L	790	19,480	36,290	6,400	(2) 15	192,600	15' 5-1/4"	9' 3"	10' 0"	8-1/2"	36' 2-1/2"	11' 2-3/4"	13' 2-3/4"	9' 0"
AT 210-336	873	19,580	36,390	6,450	(2) 20	211,000	15' 5-1/4"	9' 3"	10' 0"	8-1/2"	36' 2-1/2"	11' 2-3/4"	13' 2-3/4"	9' 0"
AT 210-436	890	18,500	35,310	5,910	(2) 30	244,100	14' 5-1/4"	8' 3"	9' 0"	8-1/2"	36' 2-1/2"	11' 2-3/4"	13' 2-3/4"	9' 0"
AT 210-536	941	19,680	36,490	6,500	(2) 25	226,300	15' 5-1/4"	9' 3"	10' 0"	8-1/2"	36' 2-1/2"	11' 2-3/4"	13' 2-3/4"	9' 0"
AT 210-636	997	19,880	36,690	6,600	(2) 30	239,600	15' 5-1/4"	9' 3"	10' 0"	8-1/2"	36' 2-1/2"	11' 2-3/4"	13' 2-3/4"	9' 0"
AT 210-736	1,044	21,140	37,950	7,230	(2) 30	235,800	16' 5-1/4"	10' 3"	11' 0"	8-1/2"	36' 2-1/2"	11' 2-3/4"	13' 2-3/4"	9' 0"
AT 210-836	1,093	20,380	37,190	6,850	(2) 40	262,300	15' 5-1/4"	9' 3"	10' 0"	8-1/2"	36' 2-1/2"	11' 2-3/4"	13' 2-3/4"	9' 0"
AT 210-936	1,140	21,640	38,450	7,480	(2) 40	258,100	16' 5-1/4"	10' 3"	11' 0"	8-1/2"	36' 2-1/2"	11' 2-3/4"	13' 2-3/4"	9' 0"
UT Addition		✦	1,400	700			1' 9-1/2"	1' 9-1/2"						

NOTE: (1) An adequately sized bleed line must be installed in the cooling tower system to prevent build-up of impurities in the recirculated water.  
 (2) Do not use catalog drawings for certified prints. Dimensions and weights are subject to change.  
 (3) Adequate spacing must be allowed for access to the cooling tower. Refer to EVAPCO's Equipment Layout Manual.  
 (4) These models are available as (2) independent operating cells. Consult the factory for details.  
 (5) Nominal Tonnage is based on 3 gpm per ton at 95 degree entering water temperature, 85 degree leaving water temperature, and 78 degree wet-bulb temperature.

- ✦ Outlet connection extends 3/8" beyond bottom flange.
- ✦ Heaviest section is upper section.
- † Height does not include fan guard. Consult factory for whether or not fan guard ships mounted.
- ✦ Please consult the factory for additional information regarding shipping and section weight changes.



## ENGINEERING DATA & DIMENSIONS

### MODELS: AT/UT/USS 212-59 to 212-99

Two-Cell Cooling Towers

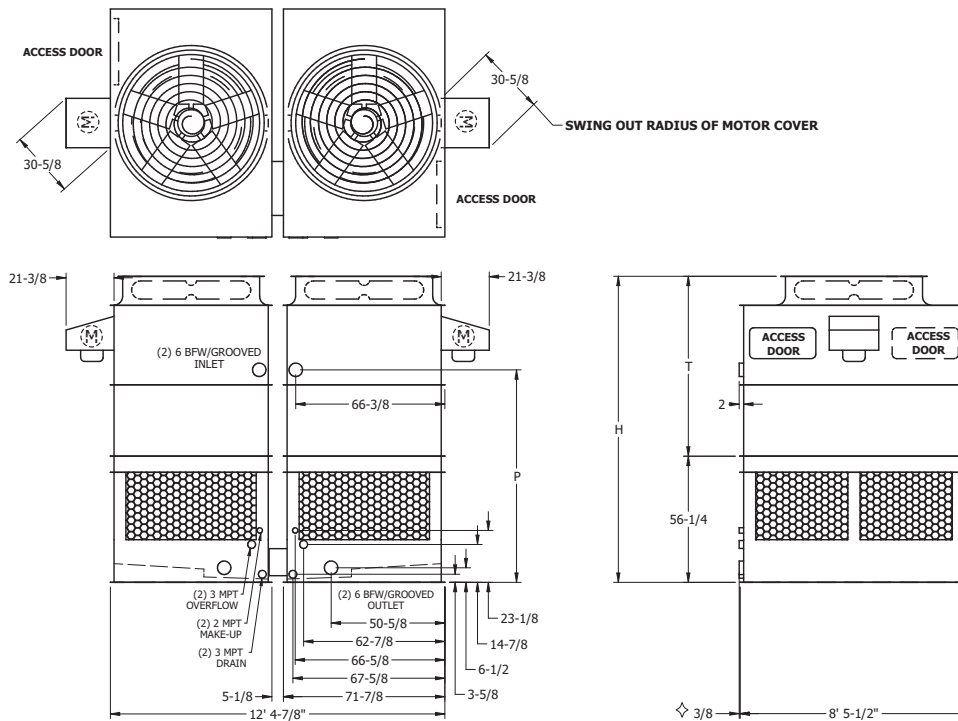

TWO CELL

Model No.	Nominal Tonnage	Weights (LBS)			Fan Motor (HP)	Air Flow (CFM)	Dimensions		
		Shipping	Operating	Heaviest Section <sup>†</sup>			H <sup>†</sup>	T <sup>†</sup>	P
AT 212-59L	179	6,080	10,160	1,990	(2)3	45,200	11' 4-1/4"	6' 8"	7' 10-1/2"
AT 212-59	225	6,120	10,200	2,010	(2)5	53,100	11' 4-1/4"	6' 8"	7' 10-1/2"
AT 212-69	247	6,200	10,280	2,050	(2)7.5	60,500	11' 4-1/4"	6' 8"	7' 10-1/2"
AT 212-79L	250	6,520	10,600	2,210	(2)5	52,300	12' 4-1/4"	7' 8"	8' 10-1/2"
AT 212-79	277	6,600	10,680	2,250	(2)7.5	59,400	12' 4-1/4"	7' 8"	8' 10-1/2"
AT 212-89	302	6,660	10,740	2,280	(2)10	65,100	12' 4-1/4"	7' 8"	8' 10-1/2"
AT 212-99L	315	7,100	11,180	2,500	(2)10	64,000	13' 4-1/4"	8' 8"	9' 10-1/2"
AT 212-99	344	7,240	11,320	2,570	(2)15	72,800	13' 4-1/4"	8' 8"	9' 10-1/2"
UT Addition		✦	300	150			1' 1"	1' 1"	

NOTE: (1) An adequately sized bleed line must be installed in the cooling tower system to prevent build-up of impurities in the recirculated water.  
 (2) Do not use catalog drawings for certified prints. Dimensions and weights are subject to change.  
 (3) Adequate spacing must be allowed for access to the cooling tower. Refer to EVAPCO's Equipment Layout Manual.  
 (4) These models are available as (2) independent operating cells. Consult the factory for details.  
 (5) Nominal Tonnage is based on 3 gpm per ton at 95 degree entering water temperature, 85 degree leaving water temperature, and 78 degree wet-bulb temperature.

- ◇ Outlet connection extends 3/8" beyond bottom flange.
- † Heaviest section is upper section.
- † Height includes fan guard which ships factory mounted.
- ✦ Please consult the factory for additional information regarding shipping and section weight changes.



# AT/UT/USS

## ENGINEERING DATA & DIMENSIONS

### MODELS: AT/UT/USS 212-024 to 212-928

Two-Cell Cooling Towers

\*212-024 to 212-924  
(2) 8" Inlets  
(2) 8" Outlets

\*212-128 to 212-928  
(2) 10" Inlets  
(2) 10" Outlets

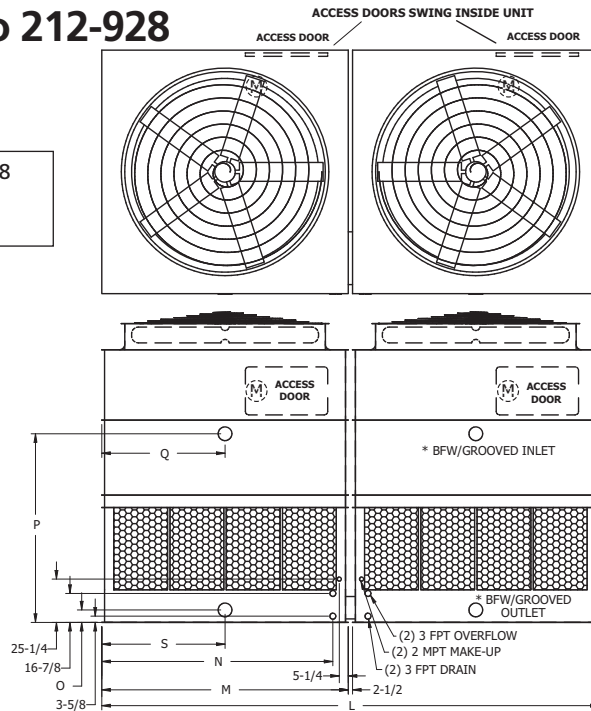
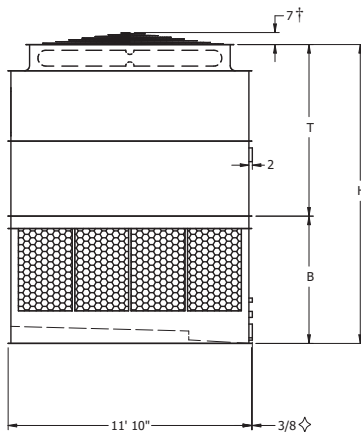

Model No.	Nominal Tonnage	Weights (LBS)			Fan Motor (HP)	Air Flow (CFM)	Dimensions							
		Shipping	Operating	Heaviest Section†			H†	T†	P	O	L	M	N	S&Q
AT 212-024L	667	14,840	27,260	5,000	(2) 15	162,700	14' 6-1/4"	8' 4"	9' 2"	7-1/4"	24' 2"	11' 11-3/4"	11' 2-3/4"	5' 11-7/8"
AT 212-024	729	14,940	27,360	5,050	(2) 20	178,300	14' 6-1/4"	8' 4"	9' 2"	7-1/4"	24' 2"	11' 11-3/4"	11' 2-3/4"	5' 11-7/8"
AT 212-124L	633	15,640	28,060	5,400	(2) 10	140,900	15' 6-1/4"	9' 4"	10' 2"	7-1/4"	24' 2"	11' 11-3/4"	11' 2-3/4"	5' 11-7/8"
AT 212-124	740	15,920	28,340	5,540	(2) 15	160,100	15' 6-1/4"	9' 4"	10' 2"	7-1/4"	24' 2"	11' 11-3/4"	11' 2-3/4"	5' 11-7/8"
AT 212-224	782	15,040	27,460	5,100	(2) 25	191,500	14' 6-1/4"	8' 4"	9' 2"	7-1/4"	24' 2"	11' 11-3/4"	11' 2-3/4"	5' 11-7/8"
AT 212-324	807	16,020	28,440	5,590	(2) 20	175,300	15' 6-1/4"	9' 4"	10' 2"	7-1/4"	24' 2"	11' 11-3/4"	11' 2-3/4"	5' 11-7/8"
AT 212-424	828	15,240	27,660	5,200	(2) 30	202,900	14' 6-1/4"	8' 4"	9' 2"	7-1/4"	24' 2"	11' 11-3/4"	11' 2-3/4"	5' 11-7/8"
AT 212-524	868	16,120	28,540	5,640	(2) 25	188,000	15' 6-1/4"	9' 4"	10' 2"	7-1/4"	24' 2"	11' 11-3/4"	11' 2-3/4"	5' 11-7/8"
AT 212-624L	843	17,000	29,420	6,080	(2) 20	172,400	16' 6-1/4"	10' 4"	11' 2"	7-1/4"	24' 2"	11' 11-3/4"	11' 2-3/4"	5' 11-7/8"
AT 212-624	908	17,100	29,520	6,130	(2) 25	184,800	16' 6-1/4"	10' 4"	11' 2"	7-1/4"	24' 2"	11' 11-3/4"	11' 2-3/4"	5' 11-7/8"
AT 212-724	922	16,320	28,740	5,740	(2) 30	199,000	15' 6-1/4"	9' 4"	10' 2"	7-1/4"	24' 2"	11' 11-3/4"	11' 2-3/4"	5' 11-7/8"
AT 212-824	963	17,300	29,720	6,230	(2) 30	195,700	16' 6-1/4"	10' 4"	11' 2"	7-1/4"	24' 2"	11' 11-3/4"	11' 2-3/4"	5' 11-7/8"
AT 212-924	1,030	17,800	30,220	6,480	(2) 40	214,300	16' 6-1/4"	10' 4"	11' 2"	7-1/4"	24' 2"	11' 11-3/4"	11' 2-3/4"	5' 11-7/8"
UT Addition		✱	1,400	700			1' 9-1/2"	1' 9-1/2"						
AT 212-128L	787	16,260	30,920	5,490	(2) 20	194,000	15' 6-1/4"	8' 4"	10' 1"	8-1/2"	28' 2"	13' 11-3/4"	13' 2-3/4"	6' 11-7/8"
AT 212-128	850	16,380	31,040	5,550	(2) 25	208,400	15' 6-1/4"	8' 4"	10' 1"	8-1/2"	28' 2"	13' 11-3/4"	13' 2-3/4"	6' 11-7/8"
AT 212-228L	810	17,460	32,120	6,090	(2) 15	174,000	16' 6-1/4"	9' 4"	11' 1"	8-1/2"	28' 2"	13' 11-3/4"	13' 2-3/4"	6' 11-7/8"
AT 212-228	877	17,580	32,240	6,150	(2) 20	190,900	16' 6-1/4"	9' 4"	11' 1"	8-1/2"	28' 2"	13' 11-3/4"	13' 2-3/4"	6' 11-7/8"
AT 212-328	900	16,520	31,180	5,620	(2) 30	220,700	15' 6-1/4"	8' 4"	10' 1"	8-1/2"	28' 2"	13' 11-3/4"	13' 2-3/4"	6' 11-7/8"
AT 212-428	942	17,700	32,360	6,210	(2) 25	204,700	16' 6-1/4"	9' 4"	11' 1"	8-1/2"	28' 2"	13' 11-3/4"	13' 2-3/4"	6' 11-7/8"
AT 212-528L	921	18,620	33,280	6,670	(2) 20	187,600	17' 6-1/4"	10' 4"	12' 1"	8-1/2"	28' 2"	13' 11-3/4"	13' 2-3/4"	6' 11-7/8"
AT 212-528	987	18,740	33,400	6,730	(2) 25	201,200	17' 6-1/4"	10' 4"	12' 1"	8-1/2"	28' 2"	13' 11-3/4"	13' 2-3/4"	6' 11-7/8"
AT 212-628	1,002	17,840	32,500	6,280	(2) 30	216,700	16' 6-1/4"	9' 4"	11' 1"	8-1/2"	28' 2"	13' 11-3/4"	13' 2-3/4"	6' 11-7/8"
AT 212-728	1,049	18,880	33,540	6,800	(2) 30	213,200	17' 6-1/4"	10' 4"	12' 1"	8-1/2"	28' 2"	13' 11-3/4"	13' 2-3/4"	6' 11-7/8"
AT 212-828	1,097	18,360	33,020	6,540	(2) 40	237,200	16' 6-1/4"	9' 4"	11' 1"	8-1/2"	28' 2"	13' 11-3/4"	13' 2-3/4"	6' 11-7/8"
AT 212-928	1,147	19,400	34,060	7,060	(2) 40	233,100	17' 6-1/4"	10' 4"	12' 1"	8-1/2"	28' 2"	13' 11-3/4"	13' 2-3/4"	6' 11-7/8"
UT Addition		✱	1,400	700			1' 9-1/2"	1' 9-1/2"						

NOTE: (1) An adequately sized bleed line must be installed in the cooling tower system to prevent build-up of impurities in the recirculated water.  
 (2) Do not use catalog drawings for certified prints. Dimensions and weights are subject to change.  
 (3) Adequate spacing must be allowed for access to the cooling tower. Refer to EVAPCO's Equipment Layout Manual.  
 (4) These models are available as (2) independent operating cells. Consult the factory for details.  
 (5) Nominal Tonnage is based on 3 gpm per ton at 95 degree entering water temperature, 85 degree leaving water temperature, and 78 degree wet-bulb temperature.

- ◇ Outlet connection extends 3/8" beyond bottom flange.
- ◆ Heaviest section is upper section.
- † Height does not include fan guard. Consult factory for whether or not fan guard ships mounted.
- ✱ Please consult the factory for additional information regarding shipping and section weight changes.



# AT/UT/USS

## ENGINEERING DATA & DIMENSIONS

### MODELS: AT/UT/USS 212-036 to 212-936

Two-Cell Cooling Towers

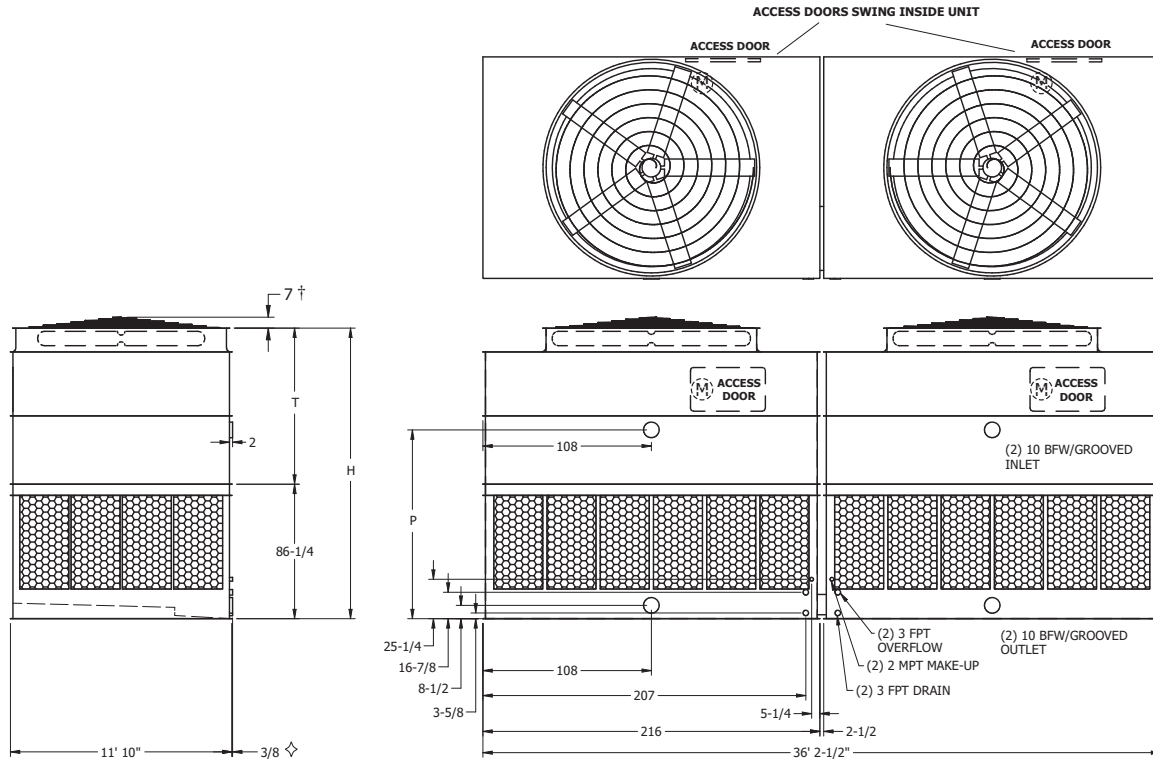

TWO CELL

Model No.	Nominal Tonnage	Weights (LBS)			Fan Motor (HP)	Air Flow (CFM)	Dimensions		
		Shipping	Operating	Heaviest Section <sup>†</sup>			H <sup>†</sup>	T <sup>†</sup>	P
AT 212-036L	977	22,340	40,880	7,480	(2) 15	216900	16' 6-1/4"	9' 4"	11' 1"
AT 212-036	1,092	22,460	41,000	7,540	(2) 20	237300	16' 6-1/4"	9' 4"	11' 1"
AT 212-136L	1,051	21,000	39,540	6,810	(2) 25	259200	15' 6-1/4"	8' 4"	10' 1"
AT 212-136	1,107	21,220	39,760	6,920	(2) 30	274700	15' 6-1/4"	8' 4"	10' 1"
AT 212-236L	1,145	23,940	42,480	8,280	(2) 20	233600	17' 6-1/4"	10' 4"	12' 1"
AT 212-236	1,213	24,040	42,580	8,330	(2) 25	250800	17' 6-1/4"	10' 4"	12' 1"
AT 212-336	1,227	22,780	41,320	7,700	(2) 30	270100	16' 6-1/4"	9' 4"	11' 1"
AT 212-436	1,283	24,260	42,800	8,440	(2) 30	265800	17' 6-1/4"	8' 4"	12' 1"
AT 212-536	1,350	23,300	41,840	7,960	(2) 40	295500	16' 6-1/4"	9' 4"	11' 1"
AT 212-636	1,409	24,780	43,320	8,700	(2) 40	290700	17' 6-1/4"	10' 4"	12' 1"
AT 212-736	1,448	23,420	41,960	8,020	(2) 50	317100	16' 6-1/4"	9' 4"	11' 1"
AT 212-836	1,513	24,900	43,440	8,760	(2) 50	311400	17' 6-1/4"	10' 4"	12' 1"
AT 212-936	1,570	25,120	43,660	8,870	(2) 60	329900	17' 6-1/4"	10' 4"	12' 1"
UT Addition		✦	2,400	1,200			1' 3-1/2"	1' 3-1/2"	

NOTE: (1) An adequately sized bleed line must be installed in the cooling tower system to prevent build-up of impurities in the recirculated water.  
 (2) Do not use catalog drawings for certified prints. Dimensions and weights are subject to change.  
 (3) Adequate spacing must be allowed for access to the cooling tower. Refer to EVAPCO's Equipment Layout Manual.  
 (4) These models are available as (2) independent operating cells. Consult the factory for details.  
 (5) Nominal Tonnage is based on 3 gpm per ton at 95 degree entering water temperature, 85 degree leaving water temperature, and 78 degree wet-bulb temperature.

✦ Outlet connection extends 3/8" beyond bottom flange.  
 † Heaviest section is upper section.  
 ‡ Height does not include fan guard. Consult factory for whether or not fan guard ships mounted.  
 ✦ Please consult the factory for additional information regarding shipping and section weight changes.





# AT/UT/USS

## ENGINEERING DATA & DIMENSIONS

### MODELS: AT/UT/USS 214-0148 to 214-1248

Two-Cell Cooling Towers

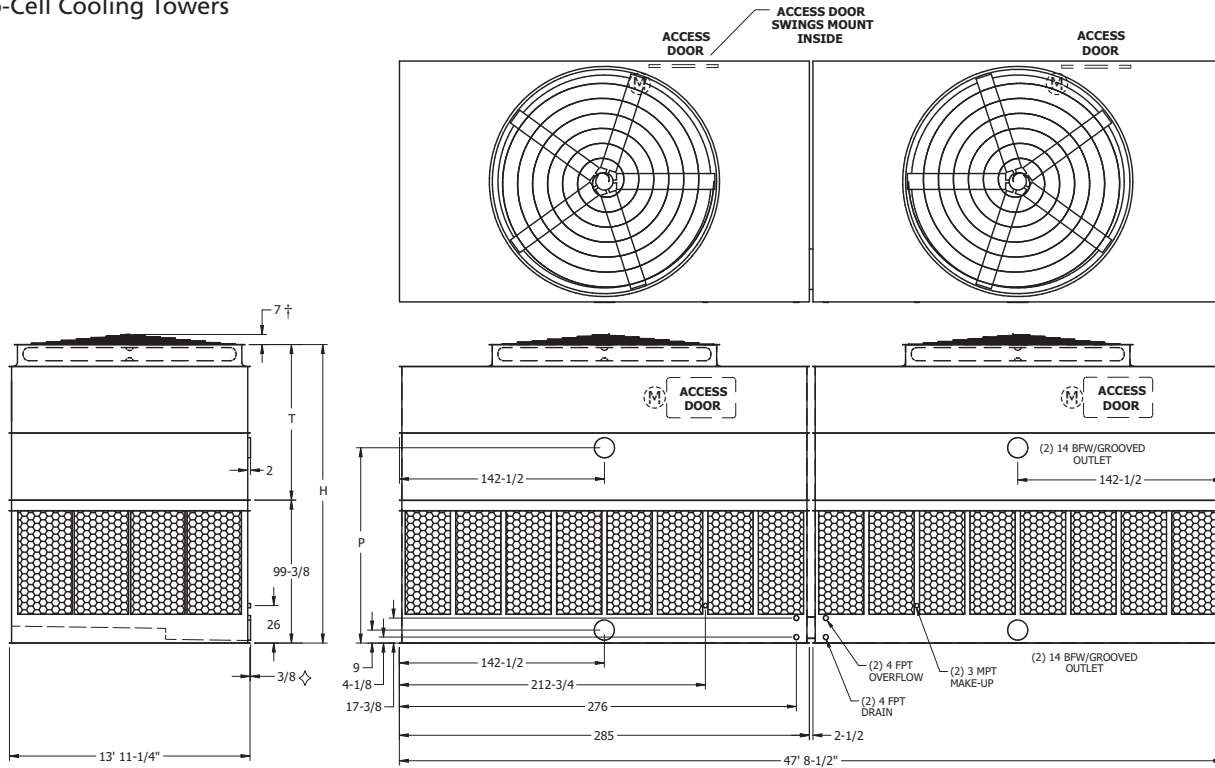

Model No.	Nominal Tonnage	Weights (LBS)			Fan Motor (HP)	Air Flow (CFM)	Dimensions		
		Shipping	Operating	Heaviest Section <sup>†</sup>			H <sup>†</sup>	T <sup>†</sup>	P
AT 214-0148L	1,336	32,740	64,440	10,650	(2) 25	336,700	17' 5-5/8"	9' 2-1/4"	11' 3-7/8"
AT 214-0148	1,410	32,780	64,480	10,670	(2) 30	357,000	17' 5-5/8"	9' 2-1/4"	11' 3-7/8"
AT 214-0248	1,527	33,080	64,780	10,820	(2) 40	391,200	17' 5-5/8"	9' 2-1/4"	11' 3-7/8"
AT 214-0348	1,641	33,780	65,480	11,170	(2) 50	420,400	17' 5-5/8"	9' 2-1/4"	11' 3-7/8"
AT 214-0448L	1,514	36,800	68,500	12,680	(2) 20	301,100	19' 5-5/8"	11' 2-1/4"	13' 3-7/8"
AT 214-0448	1,637	36,900	68,600	12,730	(2) 25	323,100	19' 5-5/8"	11' 2-1/4"	13' 3-7/8"
AT 214-0548	1,713	36,940	68,640	12,750	(2) 30	343,300	19' 5-5/8"	11' 2-1/4"	13' 3-7/8"
AT 214-0648L	1,589	34,860	66,560	11,710	(2) 30	351,100	18' 5-5/8"	10' 2-1/4"	12' 3-7/8"
AT 214-0648	1,748	35,160	66,860	11,860	(2) 40	384,300	18' 5-5/8"	10' 2-1/4"	12' 3-7/8"
AT 214-0748	1,860	37,240	68,940	12,900	(2) 40	378,000	19' 5-5/8"	11' 2-1/4"	13' 3-7/8"
AT 214-0848	1,960	37,940	69,640	13,250	(2) 50	405,900	19' 5-5/8"	11' 2-1/4"	13' 3-7/8"
AT 214-0948	1,978	36,200	67,900	12,380	(2) 60	436,800	18' 5-5/8"	10' 2-1/4"	12' 3-7/8"
AT 214-1048	2,075	38,280	69,980	13,420	(2) 60	429,900	19' 5-5/8"	11' 2-1/4"	13' 3-7/8"
AT 214-1148	2,230	38,760	70,460	13,660	(2) 75	471,200	19' 5-5/8"	11' 2-1/4"	13' 3-7/8"
AT 214-1248**	2,359	39,640	71,340	14,100	(2) 100	505,100	19' 5-5/8"	11' 2-1/4"	13' 3-7/8"
UT Addition		✦	2,500	1,250			1' 1-1/2"	1' 1-1/2"	

- NOTE: (1) An adequately sized bleed line must be installed in the cooling tower system to prevent build-up of impurities in the recirculated water.  
 (2) Do not use catalog drawings for certified prints. Dimensions and weights are subject to change.  
 (3) Adequate spacing must be allowed for access to the cooling tower. Refer to EVAPCO's Equipment Layout Manual.  
 (4) These models are available as (2) independent operating cells. Consult the factory for details.  
 (5) Nominal Tonnage is based on 3 gpm per ton at 95 degree entering water temperature, 85 degree leaving water temperature, and 78 degree wet-bulb temperature.

- ✦ Outlet connection extends 3/8" beyond bottom flange.
- ✦ Heaviest section is upper section.
- † Height does not include fan guard. Consult factory for whether or not fan guard ships mounted.
- ✦ Please consult the factory for additional information regarding shipping and section weight changes.

\*\* Model available with gear drive only. Motor and access door located on 13' 11-1/4" unit end. Super Low Sound Fan is not available on this unit.

# AT/UT/USS

## ENGINEERING DATA & DIMENSIONS

### MODELS: AT/UT/USS 214-552 to 214-952

Two-Cell Cooling Towers

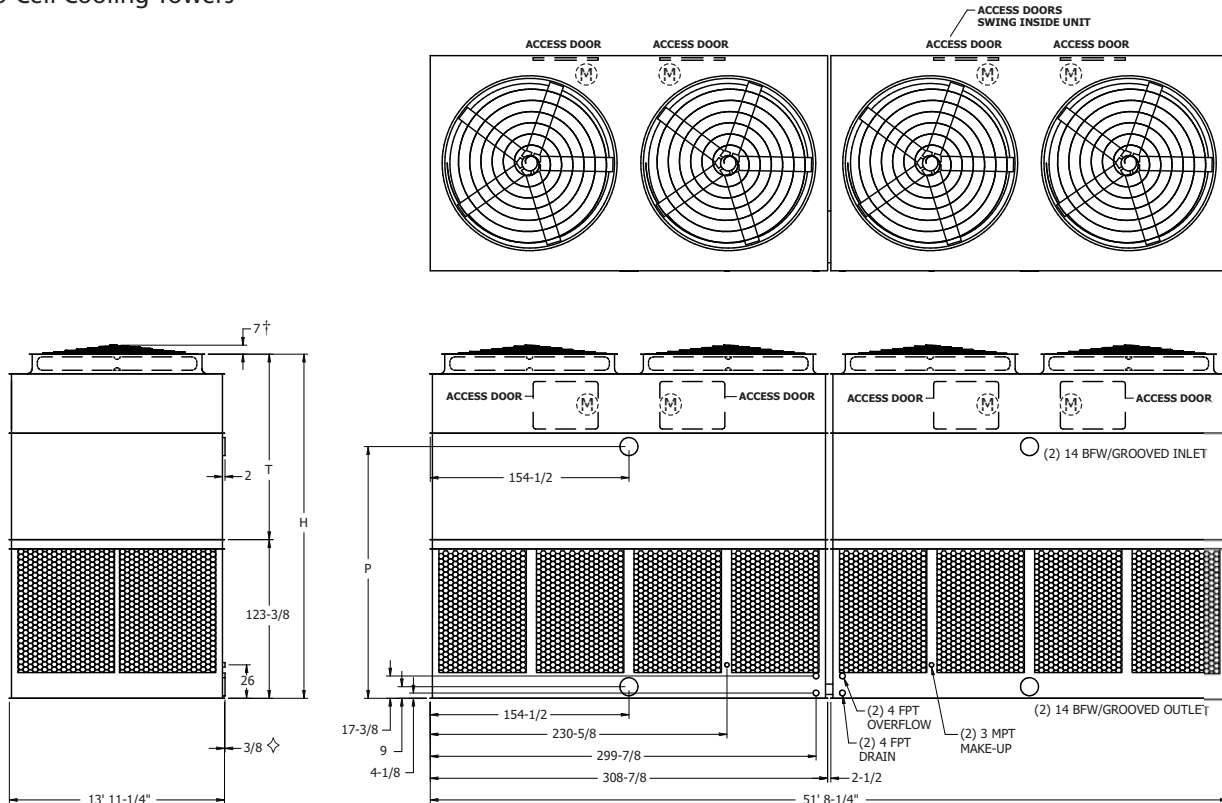

TWO CELL

Model No.	Nominal Tonnage	Weights (LBS)			Fan Motor (HP)	Air Flow (CFM)	Dimensions		
		Shipping	Operating	Heaviest Section <sup>†</sup>			H <sup>†</sup>	T <sup>†</sup>	P
AT 214-552	1,971	49,200	82,860	17,660	(4)20	393,500	22' 3-1/2"	12' 1/8"	16' 3-3/4"
AT 214-652	2,119	49,320	82,980	17,720	(4)25	422,100	22' 3-1/2"	12' 1/8"	16' 3-3/4"
AT 214-752	2,245	49,520	83,180	17,820	(4)30	446,800	22' 3-1/2"	12' 1/8"	16' 3-3/4"
AT 214-852	2,452	50,160	83,820	18,140	(4)40	488,700	22' 3-1/2"	12' 1/8"	16' 3-3/4"
AT 214-952	2,622	50,200	83,860	18,160	(4)50	523,700	22' 3-1/2"	12' 1/8"	16' 3-3/4"
UT Addition		♣	4,800	♣			1' 3-1/2"	1' 3-1/2"	

NOTE: (1) An adequately sized bleed line must be installed in the cooling tower system to prevent build-up of impurities in the recirculated water.  
 (2) Do not use catalog drawings for certified prints. Dimensions and weights are subject to change.  
 (3) Adequate spacing must be allowed for access to the cooling tower. Refer to EVAPCO's Equipment Layout Manual.  
 (4) These models are available as (2) independent operating cells. Consult the factory for details.  
 (5) Nominal Tonnage is based on 3 gpm per ton at 95 degree entering water temperature, 85 degree leaving water temperature, and 78 degree wet-bulb temperature.

- ◇ Outlet connection extends 3/8" beyond bottom flange.
- ♣ Heaviest section is upper section.
- † Height does not include fan guard. Consult factory for whether or not fan guard ships mounted.
- ♣ Please consult the factory for additional information regarding shipping and section weight changes.





# AT/UT/USS

## ENGINEERING DATA & DIMENSIONS

### MODELS: AT/UT/USS 215-29 to 215-99

Two-Cell Cooling Towers

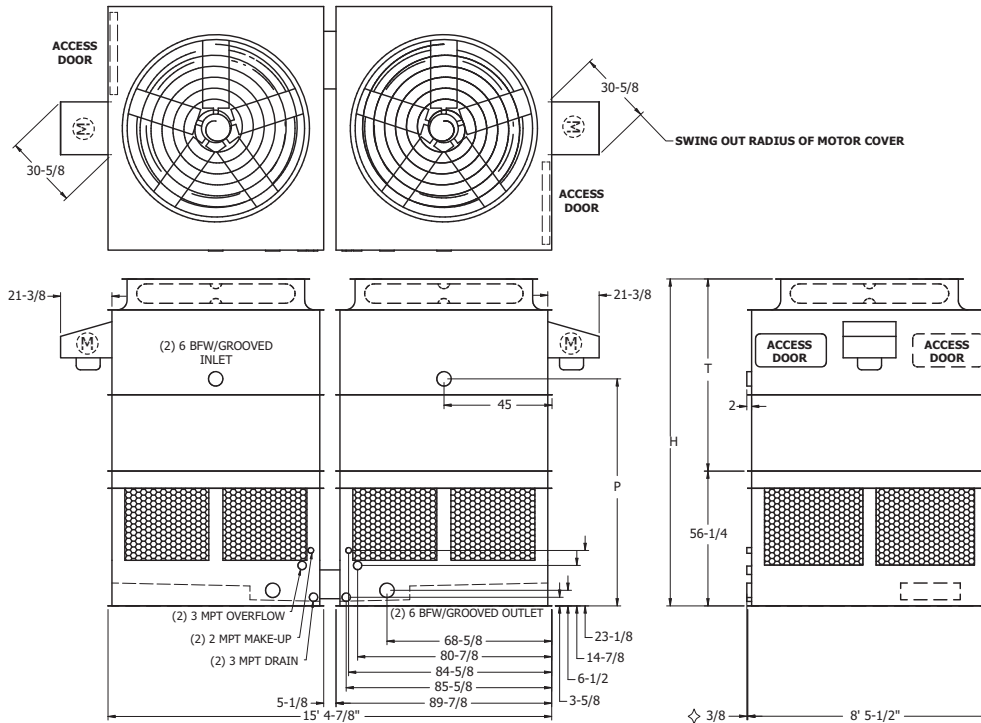

Model No.	Nominal Tonnage	Weights (LBS)			Fan Motor (HP)	Air Flow (CFM)	Dimensions		
		Shipping	Operating	Heaviest Section <sup>†</sup>			H <sup>†</sup>	T <sup>†</sup>	P
AT 215-29L	217	6,860	11,700	2,260	(2)3	53,200	11' 4-1/4"	6' 8"	7' 10-1/2"
AT 215-29	274	6,900	11,740	2,280	(2)5	62,600	11' 4-1/4"	6' 8"	7' 10-1/2"
AT 215-39	297	6,980	11,820	2,320	(2)7.5	71,400	11' 4-1/4"	6' 8"	7' 10-1/2"
AT 215-49	319	7,040	11,880	2,350	(2)10	78,300	11' 4-1/4"	6' 8"	7' 10-1/2"
AT 215-59L	304	7,360	12,200	2,510	(2)5	61,600	12' 4-1/4"	7' 8"	8' 10-1/2"
AT 215-59	331	7,440	12,280	2,550	(2)7.5	70,200	12' 4-1/4"	7' 8"	8' 10-1/2"
AT 215-69	358	7,500	12,340	2,580	(2)10	76,900	12' 4-1/4"	7' 8"	8' 10-1/2"
AT 215-79L	346	7,980	12,820	2,820	(2)7.5	69,100	13' 4-1/4"	8' 8"	9' 10-1/2"
AT 215-79	373	8,040	12,880	2,850	(2)10	75,700	13' 4-1/4"	8' 8"	9' 10-1/2"
AT 215-89	393	7,620	12,460	2,640	(2)15	87,500	12' 4-1/4"	7' 8"	8' 10-1/2"
AT 215-99	414	8,160	13,000	2,910	(2)15	86,000	13' 4-1/4"	8' 8"	9' 10-1/2"
UT Addition		✦	300	150			1' 5"	1' 5"	

- NOTE: (1) An adequately sized bleed line must be installed in the cooling tower system to prevent build-up of impurities in the recirculated water.  
 (2) Do not use catalog drawings for certified prints. Dimensions and weights are subject to change.  
 (3) Adequate spacing must be allowed for access to the cooling tower. Refer to EVAPCO's Equipment Layout Manual.  
 (4) These models are available as (2) independent operating cells. Consult the factory for details.  
 (5) Nominal Tonnage is based on 3 gpm per ton at 95 degree entering water temperature, 85 degree leaving water temperature, and 78 degree wet-bulb temperature.

- ✦ Outlet connection extends 3/8" beyond bottom flange.
- ✦ Heaviest section is upper section.
- † Height includes fan guard which ships factory mounted.
- ✦ Please consult the factory for additional information regarding shipping and section weight changes.



## ENGINEERING DATA & DIMENSIONS

### MODELS: AT/UT/USS 217-59 to 217-911

Two-Cell Cooling Towers

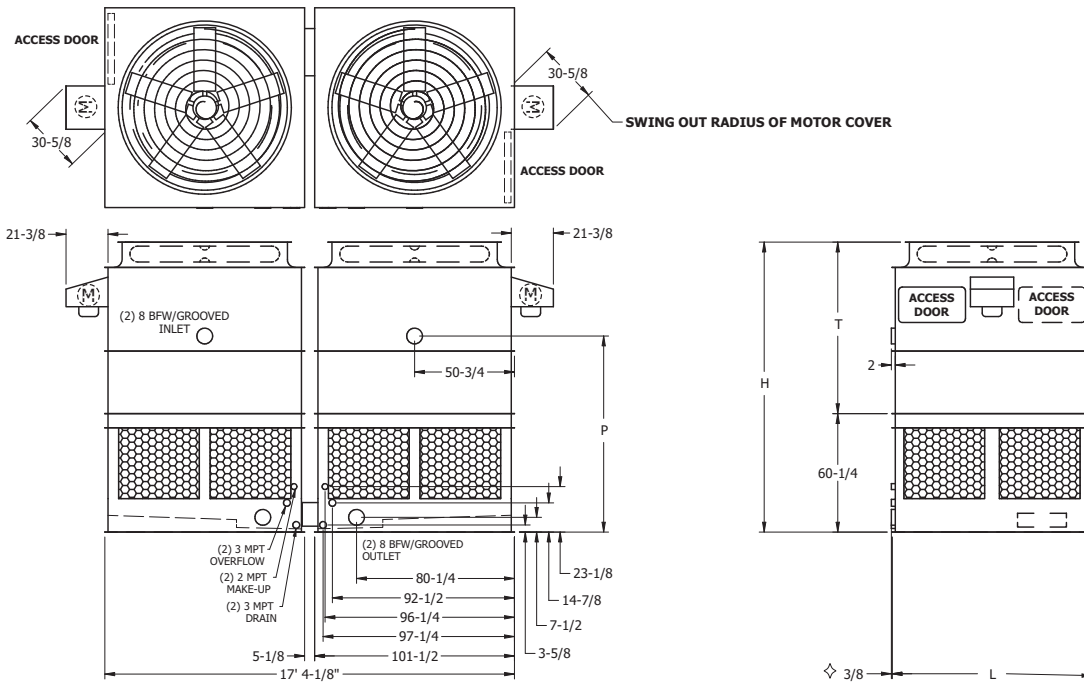

Model No.	Nominal Tonnage	Weights (LBS)			Fan Motor (HP)	Air Flow (CFM)	Dimensions			
		Shipping	Operating	Heaviest Section <sup>†</sup>			H <sup>†</sup>	T <sup>†</sup>	P	L
AT 217-59L	362	8,580	14,260	2,980	(2)7.5	80,200	13' 3-3/8"	8' 3-1/8"	9' 3-1/2"	8' 11-1/2"
AT 217-59	399	8,640	14,320	3,010	(2)10	87,800	13' 3-3/8"	8' 3-1/8"	9' 3-1/2"	8' 11-1/2"
AT 217-69L	356	8,100	13,780	2,740	(2)10	89,300	12' 3-3/8"	7' 3-1/8"	8' 3-1/2"	8' 11-1/2"
AT 217-69	416	8,240	13,920	2,810	(2)15	101,500	12' 3-3/8"	7' 3-1/8"	8' 3-1/2"	8' 11-1/2"
AT 217-79	464	8,780	14,460	3,080	(2)15	99,500	13' 3-3/8"	8' 3-1/8"	9' 3-1/2"	8' 11-1/2"
AT 217-89L	418	9,260	14,940	3,320	(2)10	86,400	14' 3-3/8"	9' 3-1/8"	10' 3-1/2"	8' 11-1/2"
AT 217-89	484	9,400	15,080	3,390	(2)15	97,900	14' 3-3/8"	9' 3-1/8"	10' 3-1/2"	8' 11-1/2"
AT 217-99	530	9,500	15,180	3,440	(2)20	107,100	14' 3-3/8"	9' 3-1/8"	10' 3-1/2"	8' 11-1/2"
UT Addition		✦	300	150			1' 9"	1' 9"		
AT 217-111L	316	9,060	15,660	3,060	(2)5	80,700	12' 3-3/8"	7' 3-1/8"	8' 3-1/2"	10' 5-1/2"
AT 217-111	379	9,140	15,740	3,100	(2)7.5	91,800	12' 3-3/8"	7' 3-1/8"	8' 3-1/2"	10' 5-1/2"
AT 217-211L	347	9,700	16,300	3,380	(2)5	79,600	13' 3-3/8"	8' 3-1/8"	9' 3-1/2"	10' 5-1/2"
AT 217-211	409	9,780	16,380	3,420	(2)7.5	90,500	13' 3-3/8"	8' 3-1/8"	9' 3-1/2"	10' 5-1/2"
AT 217-311	447	9,840	16,440	3,450	(2)10	99,100	13' 3-3/8"	8' 3-1/8"	10' 3-1/2"	10' 5-1/2"
AT 217-411	467	9,340	15,940	3,200	(2)15	114,600	12' 3-3/8"	7' 3-1/8"	8' 3-1/2"	10' 5-1/2"
AT 217-511L	444	10,480	17,080	3,770	(2)7.5	88,900	14' 3-3/8"	9' 3-1/8"	10' 3-1/2"	10' 5-1/2"
AT 217-511	480	10,540	17,140	3,800	(2)10	97,400	14' 3-3/8"	9' 3-1/8"	10' 3-1/2"	10' 5-1/2"
AT 217-611	516	9,980	16,580	3,520	(2)15	112,500	13' 3-3/8"	8' 3-1/8"	9' 3-1/2"	10' 5-1/2"
AT 217-711	545	10,680	17,280	3,870	(2)15	110,600	14' 3-3/8"	9' 3-1/8"	10' 3-1/2"	10' 5-1/2"
AT 217-811	576	10,080	16,680	3,570	(2)20	123,000	13' 3-3/8"	8' 3-1/8"	9' 3-1/2"	10' 5-1/2"
AT 217-911	634	10,840	17,440	3,950	(2)25	129,700	14' 3-3/8"	9' 3-1/8"	10' 3-1/2"	10' 5-1/2"
UT Addition		✦	300	150			1' 9"	1' 9"		

NOTE: (1) An adequately sized bleed line must be installed in the cooling tower system to prevent build-up of impurities in the recirculated water.  
 (2) Do not use catalog drawings for certified prints. Dimensions and weights are subject to change.  
 (3) Adequate spacing must be allowed for access to the cooling tower. Refer to EVAPCO's Equipment Layout Manual.  
 (4) These models are available as (2) independent operating cells. Consult the factory for details.  
 (5) Nominal Tonnage is based on 3 gpm per ton at 95 degree entering water temperature, 85 degree leaving water temperature, and 78 degree wet-bulb temperature.

- ✦ Outlet connection extends 3/8" beyond bottom flange.
- † Heaviest section is upper section.
- † Height includes fan guard which ships factory mounted.
- ✦ Please consult the factory for additional information regarding shipping and section weight changes.

TWO CELL



# AT/UT/USS

## ENGINEERING DATA & DIMENSIONS

### MODELS: AT/UT/USS 217-412 to 217-914

Two-Cell Cooling Towers

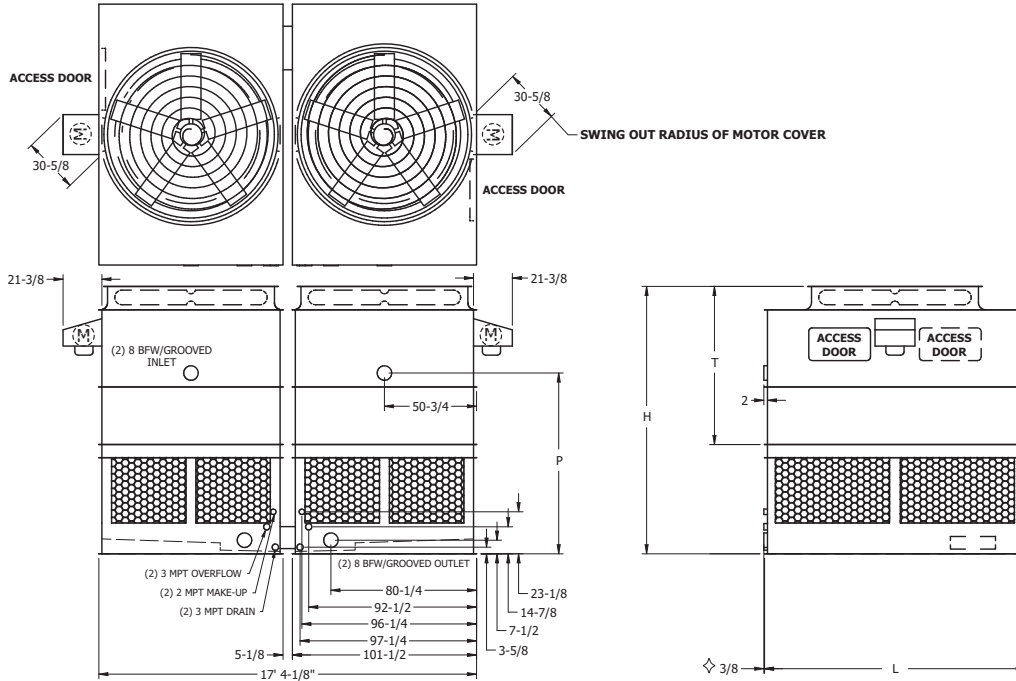

Model No.	Nominal Tonnage	Weights (LBS)			Fan Motor (HP)	Air Flow (CFM)	Dimensions			
		Shipping	Operating	Heaviest Section <sup>†</sup>			H <sup>†</sup>	T <sup>†</sup>	P	L
AT 217-412L	499	10,380	18,100	3,540	(2)15	124,300	12' 3-3/8"	7' 3-1/8"	8' 3-1/2"	11' 11-3/4"
AT 217-412	550	10,460	18,180	3,580	(2)20	136,200	12' 3-3/8"	7' 3-1/8"	8' 3-1/2"	11' 11-3/4"
AT 217-512L	499	10,940	18,660	3,820	(2)10	107,300	13' 3-3/8"	8' 3-1/8"	9' 3-1/2"	11' 11-3/4"
AT 217-512	564	11,100	18,820	3,900	(2)15	122,000	13' 3-3/8"	8' 3-1/8"	9' 3-1/2"	11' 11-3/4"
AT 217-612	622	11,180	18,900	3,940	(2)20	133,500	13' 3-3/8"	8' 3-1/8"	9' 3-1/2"	11' 11-3/4"
AT 217-712L	585	11,880	19,600	4,290	(2)15	120,100	14' 3-3/8"	9' 3-1/8"	10' 3-1/2"	11' 11-3/4"
AT 217-712	645	11,960	19,680	4,330	(2)20	131,400	14' 3-3/8"	9' 3-1/8"	10' 3-1/2"	11' 11-3/4"
AT 217-812	665	11,220	18,940	3,960	(2)25	143,200	13' 3-3/8"	8' 3-1/8"	9' 3-1/2"	11' 11-3/4"
AT 217-912	709	12,040	19,760	4,370	(2)30	149,300	14' 3-3/8"	9' 3-1/8"	10' 3-1/2"	11' 11-3/4"
UT Addition		✦	300	150			1' 9"	1' 9"		
AT 217-214L	551	11,960	20,980	4,120	(2)10	121,100	13' 9-3/8"	8' 3-1/8"	9' 9-1/2"	13' 11-3/4"
AT 217-214	621	12,120	21,140	4,200	(2)15	137,700	13' 9-3/8"	8' 3-1/8"	9' 9-1/2"	13' 11-3/4"
AT 217-314L	608	11,380	20,400	3,830	(2)20	153,600	12' 9-3/8"	7' 3-1/8"	8' 9-1/2"	13' 11-3/4"
AT 217-314	664	11,420	20,440	3,850	(2)25	164,700	12' 9-3/8"	7' 3-1/8"	8' 9-1/2"	13' 11-3/4"
AT 217-414	685	12,200	21,220	4,240	(2)20	150,600	13' 9-3/8"	8' 3-1/8"	9' 9-1/2"	13' 11-3/4"
AT 217-514L	649	13,020	22,040	4,650	(2)15	135,500	14' 9-3/8"	9' 3-1/8"	10' 9-1/2"	13' 11-3/4"
AT 217-514	714	13,100	22,120	4,690	(2)20	148,300	14' 9-3/8"	9' 3-1/8"	10' 9-1/2"	13' 11-3/4"
AT 217-614	744	12,240	21,260	4,260	(2)25	161,500	13' 9-3/8"	8' 3-1/8"	9' 9-1/2"	13' 11-3/4"
AT 217-714	773	13,140	22,160	4,710	(2)25	158,900	14' 9-3/8"	9' 3-1/8"	10' 9-1/2"	13' 11-3/4"
AT 217-814	787	12,280	21,300	4,280	(2)30	171,100	13' 9-3/8"	8' 3-1/8"	9' 9-1/2"	13' 11-3/4"
AT 217-914	815	13,180	22,200	4,730	(2)30	168,200	14' 9-3/8"	9' 3-1/8"	10' 9-1/2"	13' 11-3/4"
UT Addition		✦	300	150			1' 9"	1' 9"		

NOTE: (1) An adequately sized bleed line must be installed in the cooling tower system to prevent build-up of impurities in the recirculated water.  
 (2) Do not use catalog drawings for certified prints. Dimensions and weights are subject to change.  
 (3) Adequate spacing must be allowed for access to the cooling tower. Refer to EVAPCO's Equipment Layout Manual.  
 (4) These models are available as (2) independent operating cells. Consult the factory for details.  
 (5) Nominal Tonnage is based on 3 gpm per ton at 95 degree entering water temperature, 85 degree leaving water temperature, and 78 degree wet-bulb temperature.

- ◇ Outlet connection extends 3/8" beyond bottom flange.
- ✦ Heaviest section is upper section.
- † Height includes fan guard which ships factory mounted.
- ✦ Please consult the factory for additional information regarding shipping and section weight changes.



# AT/UT/USS

## ENGINEERING DATA & DIMENSIONS

### MODELS: AT/UT/USS 220-112 to 220-918 Two-Cell Cooling Towers

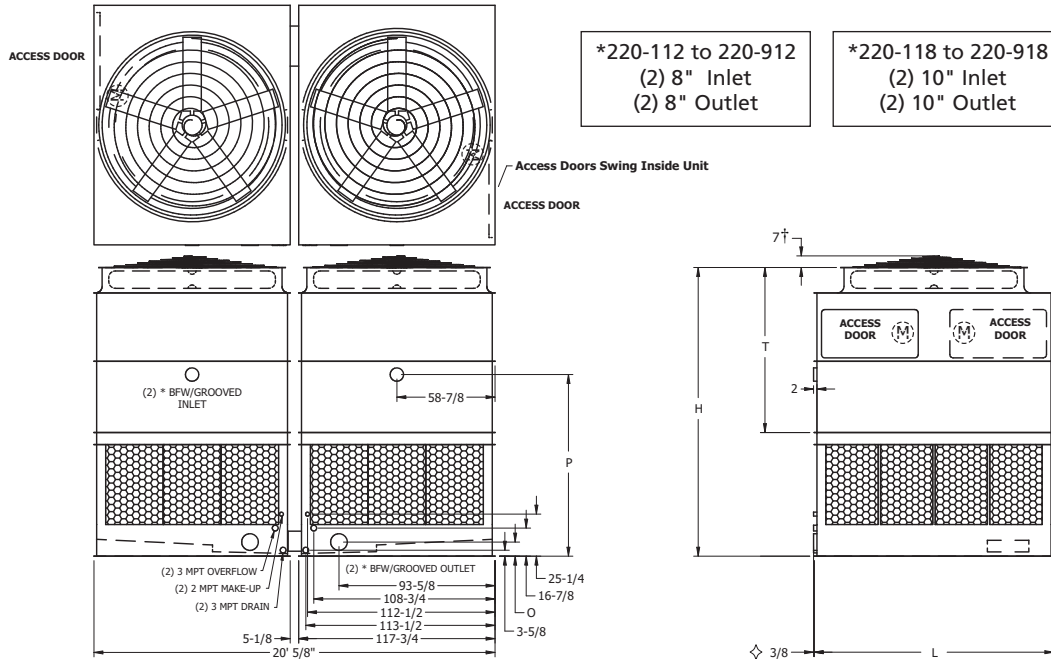

TWO CELL

Model No.	Nominal Tonnage	Weights (LBS)			Fan Motor (HP)	Air Flow (CFM)	Dimensions				
		Shipping	Operating	Heaviest Section†			H†	T†	P	O	L
AT 220-112L	529	14,000	25,080	4,750	(2) 10	126,700	15' 5-1/4"	9' 3"	10' 1"	7-1/4"	11' 11-3/4"
AT 220-112	618	14,000	25,080	4,750	(2) 15	143,900	15' 5-1/4"	9' 3"	10' 1"	7-1/4"	11' 11-3/4"
AT 220-212L	611	13,140	24,220	4,320	(2) 20	160,300	14' 5-1/4"	8' 3"	9' 1"	7-1/4"	11' 11-3/4"
AT 220-212	651	13,240	24,320	4,370	(2) 25	172,300	14' 5-1/4"	8' 3"	9' 1"	7-1/4"	11' 11-3/4"
AT 220-312	676	14,100	25,180	4,800	(2) 20	157,400	15' 5-1/4"	9' 3"	10' 1"	7-1/4"	11' 11-3/4"
AT 220-412	684	13,440	24,520	4,470	(2) 30	182,600	14' 5-1/4"	8' 3"	9' 1"	7-1/4"	11' 11-3/4"
AT 220-512	722	14,200	25,280	4,850	(2) 25	169,100	15' 5-1/4"	9' 3"	10' 1"	7-1/4"	11' 11-3/4"
AT 220-612L	701	14,940	26,020	5,220	(2) 20	155,000	16' 5-1/4"	10' 3"	11' 1"	7-1/4"	11' 11-3/4"
AT 220-612	746	15,040	26,120	5,270	(2) 25	166,300	16' 5-1/4"	10' 3"	11' 1"	7-1/4"	11' 11-3/4"
AT 220-712	760	14,400	25,480	4,950	(2) 30	179,000	15' 5-1/4"	9' 3"	10' 1"	7-1/4"	11' 11-3/4"
AT 220-812	785	15,240	26,320	5,370	(2) 30	176,300	16' 5-1/4"	10' 3"	11' 1"	7-1/4"	11' 11-3/4"
AT 220-912	820	15,740	26,820	5,620	(2) 35	185,000	16' 5-1/4"	10' 3"	11' 1"	7-1/4"	11' 11-3/4"
UT Addition		✦	1,400	700			1' 9-1/2"	1' 9-1/2"			
AT 220-118L	701	17,960	34,770	5,710	(2) 15	194,700	15' 5-1/4"	8' 3"	10' 0"	8-1/2"	18' 0"
AT 220-118	779	18,060	34,870	5,760	(2) 20	213,600	15' 5-1/4"	8' 3"	10' 0"	8-1/2"	18' 0"
AT 220-218L	727	20,600	37,410	7,030	(2) 10	165,700	17' 5-1/4"	10' 3"	12' 0"	8-1/2"	18' 0"
AT 220-218	839	20,600	37,410	7,030	(2) 15	188,600	17' 5-1/4"	10' 3"	12' 0"	8-1/2"	18' 0"
AT 220-318L	790	19,340	36,150	6,400	(2) 15	191,700	16' 5-1/4"	9' 3"	11' 0"	8-1/2"	18' 0"
AT 220-318	873	19,440	36,250	6,450	(2) 20	210,000	16' 5-1/4"	9' 3"	11' 0"	8-1/2"	18' 0"
AT 220-418	890	18,360	35,170	5,910	(2) 30	243,000	15' 5-1/4"	8' 3"	10' 0"	8-1/2"	18' 0"
AT 220-518	941	19,540	36,350	6,500	(2) 25	225,200	16' 5-1/4"	9' 3"	11' 0"	8-1/2"	18' 0"
AT 220-618	997	19,740	36,550	6,600	(2) 30	238,600	16' 5-1/4"	9' 3"	11' 0"	8-1/2"	18' 0"
AT 220-718	1,044	21,000	37,810	7,230	(2) 30	234,800	17' 5-1/4"	10' 3"	12' 0"	8-1/2"	18' 0"
AT 220-818	1,093	20,240	37,050	6,850	(2) 40	261,000	16' 5-1/4"	9' 3"	11' 0"	8-1/2"	18' 0"
AT 220-918	1,140	21,500	38,310	7,480	(2) 40	256,800	17' 5-1/4"	10' 3"	12' 0"	8-1/2"	18' 0"
UT Addition		✦	1,400	700			1' 9-1/2"	1' 9-1/2"			

NOTE: (1) An adequately sized bleed line must be installed in the cooling tower system to prevent build-up of impurities in the recirculated water.  
 (2) Do not use catalog drawings for certified prints. Dimensions and weights are subject to change.  
 (3) Adequate spacing must be allowed for access to the cooling tower. Refer to EVAPCO's Equipment Layout Manual.  
 (4) These models are available as (2) independent operating cells. Consult the factory for details.  
 (5) Nominal Tonnage is based on 3 gpm per ton at 95 degree entering water temperature, 85 degree leaving water temperature, and 78 degree wet-bulb temperature.

- ✦ Outlet connection extends 3/8" beyond bottom flange.
- ✦ Heaviest section is upper section.
- † Height does not include fan guard. Consult factory for whether or not fan guard ships mounted.
- ✦ Please consult the factory for additional information regarding shipping and section weight changes.





# AT/UT/USS

## ENGINEERING DATA & DIMENSIONS

### MODELS: AT/UT/USS 224-018 to 224-920 Two-Cell Cooling Towers

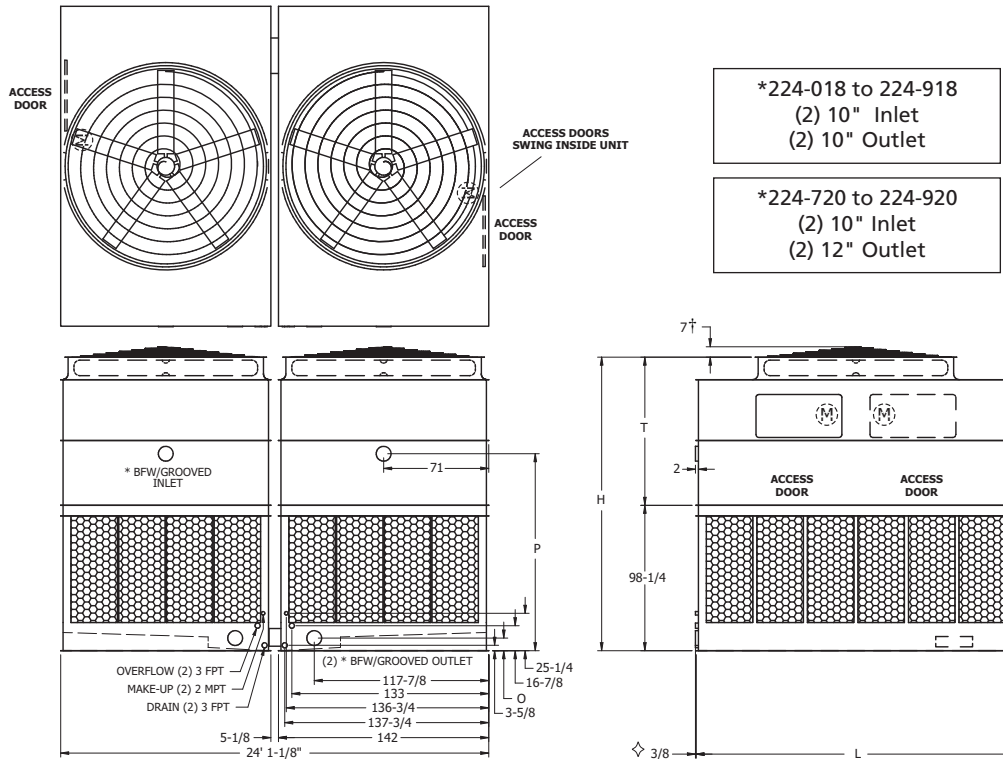

Model No.	Nominal Tonnage	Weights (LBS)			Fan Motor (HP)	Air Flow (CFM)	Dimensions				
		Shipping	Operating	Heaviest Section <sup>†</sup>			H <sup>†</sup>	T <sup>†</sup>	P	O	L
AT 224-018L	994	20,960	39,500	6,760	(2) 20	240,300	16' 6-1/4"	8' 4"	11' 1"	8-1/2"	18' 0"
AT 224-018	1,051	21,060	39,600	6,810	(2) 25	258,200	16' 6-1/4"	8' 4"	11' 1"	8-1/2"	18' 0"
AT 224-118	1,107	21,280	39,820	6,920	(2) 30	274,000	16' 6-1/4"	8' 4"	11' 1"	8-1/2"	18' 0"
AT 224-218L	1,092	22,520	41,060	7,540	(2) 20	236,500	17' 6-1/4"	9' 4"	12' 1"	8-1/2"	18' 0"
AT 224-218	1,161	22,620	41,160	7,590	(2) 25	254,100	17' 6-1/4"	9' 4"	12' 1"	8-1/2"	18' 0"
AT 224-318	1,219	21,800	40,340	7,180	(2) 40	300,100	16' 6-1/4"	8' 4"	11' 1"	8-1/2"	18' 0"
AT 224-418	1,227	22,840	41,380	7,700	(2) 30	268,800	17' 6-1/4"	9' 4"	12' 1"	8-1/2"	18' 0"
AT 224-518L	1,213	24,100	42,640	8,330	(2) 25	249,800	18' 6-1/4"	10' 4"	13' 1"	8-1/2"	18' 0"
AT 224-518	1,283	24,320	42,860	8,440	(2) 30	264,800	18' 6-1/4"	10' 4"	13' 1"	8-1/2"	18' 0"
AT 224-618	1,350	23,360	41,900	7,960	(2) 40	294,400	17' 6-1/4"	9' 4"	12' 1"	8-1/2"	18' 0"
AT 224-718	1,448	23,480	42,020	8,020	(2) 50	315,900	17' 6-1/4"	9' 4"	12' 1"	8-1/2"	18' 0"
AT 224-818	1,513	24,960	43,500	8,760	(2) 50	310,300	18' 6-1/4"	10' 4"	13' 1"	8-1/2"	18' 0"
AT 224-918	1,570	25,180	43,720	8,870	(2) 60	328,700	18' 6-1/4"	10' 4"	13' 1"	8-1/2"	18' 0"
UT Addition		✦	2,400	1,200			1' 3-1/2"	1' 3-1/2"			
AT 224-720L	1,284	25,880	46,680	9,000	(2) 30	268,500	18' 6-1/4"	10' 4"	13' 1"	9-1/2"	20' 0"
AT 224-720	1,428	26,400	47,200	9,260	(2) 40	293,700	18' 6-1/4"	10' 4"	13' 1"	9-1/2"	20' 0"
AT 224-820	1,545	26,520	47,320	9,320	(2) 50	314,700	18' 6-1/4"	10' 4"	13' 1"	9-1/2"	20' 0"
AT 224-920	1,603	26,740	47,540	9,430	(2) 60	333,500	18' 6-1/4"	10' 4"	13' 1"	9-1/2"	20' 0"
UT Addition		✦	2,400	1,200			1' 3-1/2"	1' 3-1/2"			

NOTE: (1) An adequately sized bleed line must be installed in the cooling tower system to prevent build-up of impurities in the recirculated water.  
 (2) Do not use catalog drawings for certified prints. Dimensions and weights are subject to change.  
 (3) Adequate spacing must be allowed for access to the cooling tower. Refer to EVAPCO's Equipment Layout Manual.  
 (4) These models are available as (2) independent operating cells. Consult the factory for details.  
 (5) Nominal Tonnage is based on 3 gpm per ton at 95 degree entering water temperature, 85 degree leaving water temperature, and 78 degree wet-bulb temperature.

- ◇ Outlet connection extends 3/8" beyond bottom flange.
- ◆ Heaviest section is upper section.
- † Height does not include fan guard. Consult factory for whether or not fan guard ships mounted.
- ✦ Please consult the factory for additional information regarding shipping and section weight changes.

# AT/UT/USS

## ENGINEERING DATA & DIMENSIONS

### MODELS: AT/UT/USS 228-0124 to 228-1024

Two-Cell Cooling Towers

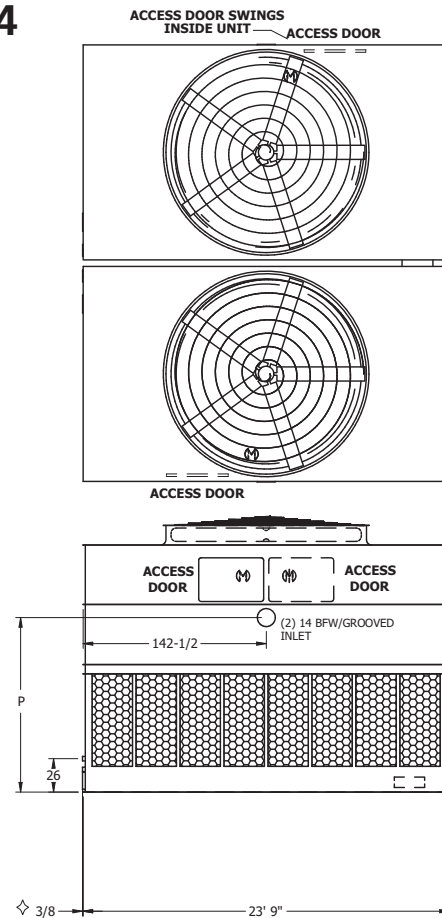
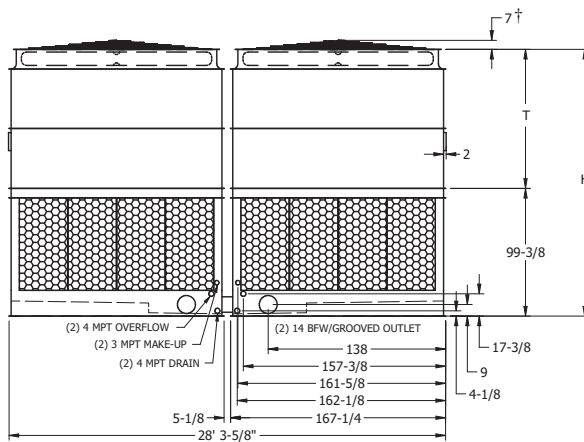

TWO CELL

Model No.	Nominal Tonnage	Weights (LBS)			Fan Motor (HP)	Air Flow (CFM)	Dimensions		
		Shipping	Operating	Heaviest Section <sup>†</sup>			H <sup>†</sup>	T <sup>†</sup>	P
AT 228-0124L	1,402	32,460	64,160	10,670	(2) 30	355,000	17' 5-5/8"	9' 2-1/4"	11' 3-7/8"
AT 228-0124	1,520	32,760	64,460	10,820	(2) 40	389,400	17' 5-5/8"	9' 2-1/4"	11' 3-7/8"
AT 228-0224	1,633	33,460	65,160	11,170	(2) 50	418,200	17' 5-5/8"	9' 2-1/4"	11' 3-7/8"
AT 228-0324L	1,508	36,480	68,180	12,680	(2) 20	300,300	19' 5-5/8"	11' 2-1/4"	13' 3-7/8"
AT 228-0324	1,630	36,580	68,280	12,730	(2) 25	322,200	19' 5-5/8"	11' 2-1/4"	13' 3-7/8"
AT 228-0424	1,706	36,620	68,320	12,750	(2) 30	342,300	19' 5-5/8"	11' 2-1/4"	13' 3-7/8"
AT 228-0524L	1,582	34,540	66,240	11,710	(2) 30	349,300	18' 5-5/8"	10' 2-1/4"	12' 3-7/8"
AT 228-0524	1,740	34,840	66,540	11,860	(2) 40	382,400	18' 5-5/8"	10' 2-1/4"	12' 3-7/8"
AT 228-0624	1,855	35,540	67,240	12,210	(2) 50	410,500	18' 5-5/8"	10' 2-1/4"	12' 3-7/8"
AT 228-0724	1,969	35,880	67,580	12,380	(2) 60	434,800	18' 5-5/8"	10' 2-1/4"	12' 3-7/8"
AT 228-0824	2,067	37,960	69,660	13,420	(2) 60	427,800	19' 5-5/8"	11' 2-1/4"	13' 3-7/8"
AT 228-0924	2,221	38,440	70,140	13,660	(2) 75	468,800	19' 5-5/8"	11' 2-1/4"	13' 3-7/8"
AT 228-1024**	2,350	39,320	71,020	14,100	(2) 100	502,600	19' 5-5/8"	11' 2-1/4"	13' 3-7/8"
UT Addition		♣	2,500	1,250			1' 1-1/2"	1' 1-1/2"	

NOTE: (1) An adequately sized bleed line must be installed in the cooling tower system to prevent build-up of impurities in the recirculated water.  
 (2) Do not use catalog drawings for certified prints. Dimensions and weights are subject to change.  
 (3) Adequate spacing must be allowed for access to the cooling tower. Refer to EVAPCO's Equipment Layout Manual.  
 (4) These models are available as (2) independent operating cells. Consult the factory for details.  
 (5) Nominal Tonnage is based on 3 gpm per ton at 95 degree entering water temperature, 85 degree leaving water temperature, and 78 degree wet-bulb temperature.

♢ Outlet connection extends 3/8" beyond bottom flange.  
 ♣ Heaviest section is upper section.  
 † Height does not include fan guard. Consult factory for whether or not fan guard ships mounted.  
 ♣ Please consult the factory for additional information regarding shipping and section weight changes.

\*\* Model available with gear drive only. Motor and access door located on 13'11-1/4" unit end. Super Low Sound Fan is not available on this unit.





# AT/UT/USS

## ENGINEERING DATA & DIMENSIONS

### MODELS: AT/UT/USS 228-526 to 228-926

Two-Cell Cooling Towers

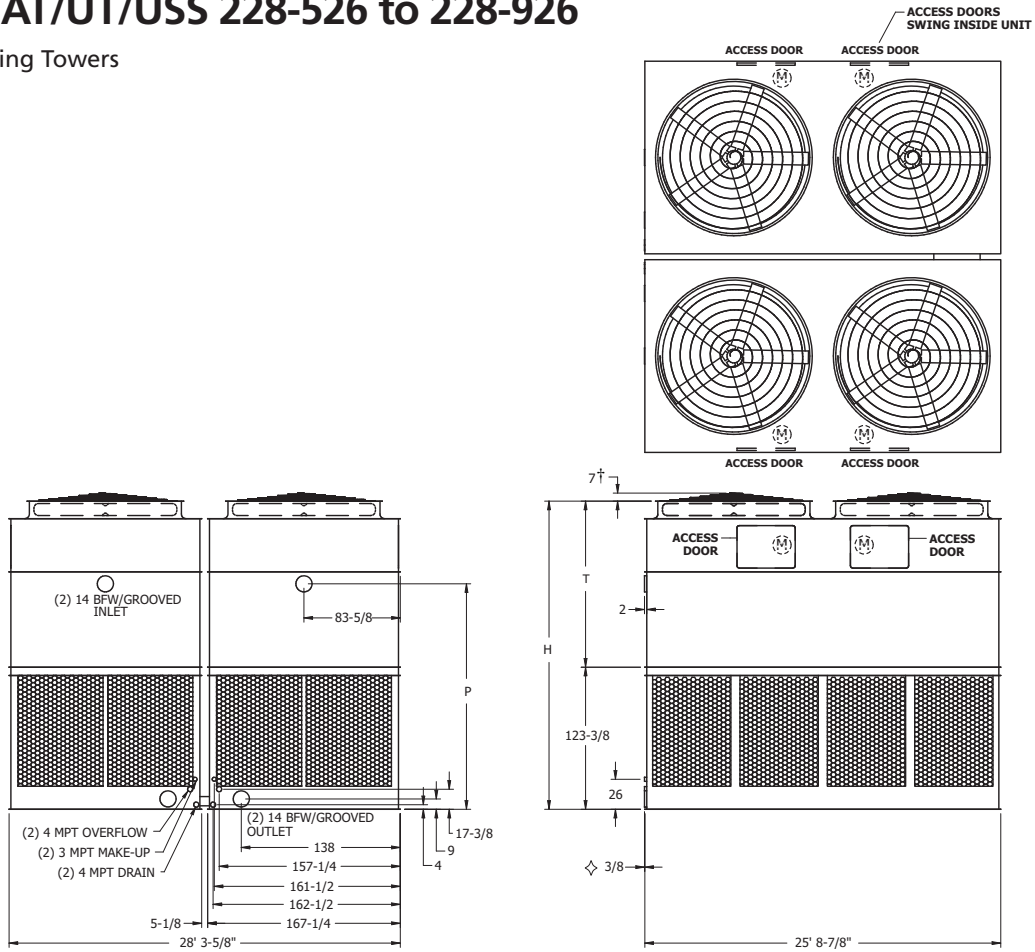

Model No.	Nominal Tonnage	Weights (LBS)			Fan Motor (HP)	Air Flow (CFM)	Dimensions		
		Shipping	Operating	Heaviest Section†			H†	T†	P
AT 228-526	1,963	48,940	82,600	17,660	(4)20	392,000	22' 3-1/2"	12' 1/8"	16' 3-3/4"
AT 228-626	2,111	49,060	82,720	17,720	(4)25	420,400	22' 3-1/2"	12' 1/8"	16' 3-3/4"
AT 228-726	2,236	49,260	82,920	17,820	(4)30	445,100	22' 3-1/2"	12' 1/8"	16' 3-3/4"
AT 228-826	2,443	49,900	83,560	18,140	(4)40	486,800	22' 3-1/2"	12' 1/8"	16' 3-3/4"
AT 228-926	2,613	49,940	83,600	18,160	(4)50	521,700	22' 3-1/2"	12' 1/8"	16' 3-3/4"
UT Addition		✦	4,800	✦			1' 3-1/2"	1' 3-1/2"	

- NOTE: (1) An adequately sized bleed line must be installed in the cooling tower system to prevent build-up of impurities in the recirculated water.  
 (2) Do not use catalog drawings for certified prints. Dimensions and weights are subject to change.  
 (3) Adequate spacing must be allowed for access to the cooling tower. Refer to EVAPCO's Equipment Layout Manual.  
 (4) These models are available as (2) independent operating cells. Consult the factory for details.  
 (5) Nominal Tonnage is based on 3 gpm per ton at 95 degree entering water temperature, 85 degree leaving water temperature, and 78 degree wet-bulb temperature.
- ✦ Outlet connection extends 3/8" beyond bottom flange.
  - ✦ Heaviest section is upper section.
  - † Height does not include fan guard. Consult factory for whether or not fan guard ships mounted.
  - ✦ Please consult the factory for additional information regarding shipping and section weight changes.



## ENGINEERING DATA & DIMENSIONS

### MODELS: AT/UT/USS 39-336 to 39-942

Three-Cell Cooling Towers

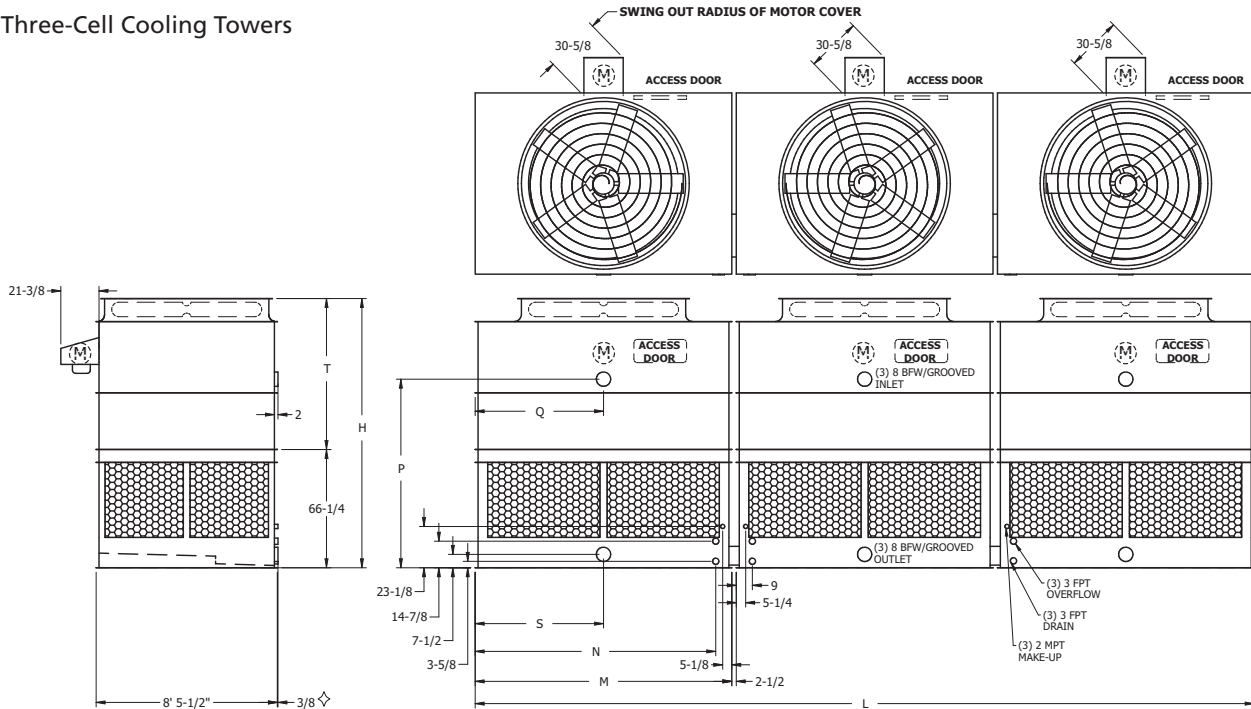

Model No.	Nominal Tonnage	Weights (LBS)			Fan Motor (HP)	Air Flow (CFM)	Dimensions						
		Shipping	Operating	Heaviest Section <sup>†</sup>			H <sup>†</sup>	T <sup>†</sup>	P	L	M	N	S&Q
AT 39-336L	605	15,300	26,880	3,430	(3) 7.5	150,900	12' 6-3/4"	7' 1/2"	8' 9-1/2"	36' 4-1/4"	11' 11-3/4"	11' 2-3/4"	5' 11-7/8"
AT 39-336	686	15,390	26,970	3,460	(3) 10	165,200	12' 6-3/4"	7' 1/2"	8' 9-1/2"	36' 4-1/4"	11' 11-3/4"	11' 2-3/4"	5' 11-7/8"
AT 39-436	765	15,630	27,210	3,540	(3) 15	188,200	12' 6-3/4"	7' 1/2"	8' 9-1/2"	36' 4-1/4"	11' 11-3/4"	11' 2-3/4"	5' 11-7/8"
AT 39-536	843	15,750	27,330	3,580	(3) 20	206,200	12' 6-3/4"	7' 1/2"	8' 9-1/2"	36' 4-1/4"	11' 11-3/4"	11' 2-3/4"	5' 11-7/8"
AT 39-636L	763	16,470	28,050	3,820	(3) 10	162,500	13' 6-3/4"	8' 1/2"	9' 9-1/2"	36' 4-1/4"	11' 11-3/4"	11' 2-3/4"	5' 11-7/8"
AT 39-636	862	16,710	28,290	3,900	(3) 15	184,900	13' 6-3/4"	8' 1/2"	9' 9-1/2"	36' 4-1/4"	11' 11-3/4"	11' 2-3/4"	5' 11-7/8"
AT 39-736	951	16,830	28,410	3,940	(3) 20	202,200	13' 6-3/4"	8' 1/2"	9' 9-1/2"	36' 4-1/4"	11' 11-3/4"	11' 2-3/4"	5' 11-7/8"
AT 39-836	1,016	16,890	28,470	3,960	(3) 25	217,100	13' 6-3/4"	8' 1/2"	9' 9-1/2"	36' 4-1/4"	11' 11-3/4"	11' 2-3/4"	5' 11-7/8"
AT 39-936L	1,050	18,060	29,640	4,350	(3) 25	213,200	14' 6-3/4"	9' 1/2"	10' 9-1/2"	36' 4-1/4"	11' 11-3/4"	11' 2-3/4"	5' 11-7/8"
AT 39-936	1,082	18,120	29,700	4,370	(3) 30	226,200	14' 6-3/4"	9' 1/2"	10' 9-1/2"	36' 4-1/4"	11' 11-3/4"	11' 2-3/4"	5' 11-7/8"
UT Addition		✦	450	150			1' 9"	1' 9"					
AT 39-242L	664	16,680	30,210	3,680	(3) 7.5	167,700	12' 6-3/4"	7' 1/2"	8' 9-1/2"	42' 4-1/4"	13' 11-3/4"	13' 2-3/4"	6' 11-7/8"
AT 39-242	754	16,770	30,300	3,710	(3) 10	183,700	12' 6-3/4"	7' 1/2"	8' 9-1/2"	42' 4-1/4"	13' 11-3/4"	13' 2-3/4"	6' 11-7/8"
AT 39-342	840	17,010	30,540	3,790	(3) 15	209,300	12' 6-3/4"	7' 1/2"	8' 9-1/2"	42' 4-1/4"	13' 11-3/4"	13' 2-3/4"	6' 11-7/8"
AT 39-442L	799	19,260	32,790	4,540	(3) 7.5	162,400	14' 6-3/4"	9' 1/2"	10' 9-1/2"	42' 4-1/4"	13' 11-3/4"	13' 2-3/4"	6' 11-7/8"
AT 39-442	884	19,350	32,880	4,570	(3) 10	177,900	14' 6-3/4"	9' 1/2"	10' 9-1/2"	42' 4-1/4"	13' 11-3/4"	13' 2-3/4"	6' 11-7/8"
AT 39-542	1,011	17,190	30,720	3,850	(3) 25	246,200	12' 6-3/4"	7' 1/2"	8' 9-1/2"	42' 4-1/4"	13' 11-3/4"	13' 2-3/4"	6' 11-7/8"
AT 39-642L	1,042	18,360	31,890	4,240	(3) 20	224,900	13' 6-3/4"	8' 1/2"	9' 9-1/2"	42' 4-1/4"	13' 11-3/4"	13' 2-3/4"	6' 11-7/8"
AT 39-642	1,130	18,420	31,950	4,260	(3) 25	241,300	13' 6-3/4"	8' 1/2"	9' 9-1/2"	42' 4-1/4"	13' 11-3/4"	13' 2-3/4"	6' 11-7/8"
AT 39-742	1,174	19,770	33,300	4,710	(3) 25	237,400	14' 6-3/4"	9' 1/2"	10' 9-1/2"	42' 4-1/4"	13' 11-3/4"	13' 2-3/4"	6' 11-7/8"
AT 39-842	1,197	18,480	32,010	4,280	(3) 30	255,700	13' 6-3/4"	8' 1/2"	9' 9-1/2"	42' 4-1/4"	13' 11-3/4"	13' 2-3/4"	6' 11-7/8"
AT 39-942	1,239	19,830	33,360	4,730	(3) 30	251,200	14' 6-3/4"	9' 1/2"	10' 9-1/2"	42' 4-1/4"	13' 11-3/4"	13' 2-3/4"	6' 11-7/8"
UT Addition		✦	450	150			1' 9"	1' 9"					

- NOTE: (1) An adequately sized bleed line must be installed in the cooling tower system to prevent build-up of impurities in the recirculated water.  
 (2) Do not use catalog drawings for certified prints. Dimensions and weights are subject to change.  
 (3) Adequate spacing must be allowed for access to the cooling tower. Refer to EVAPCO's Equipment Layout Manual.  
 (4) These models are available as (3) independent operating cells. Consult the factory for details.  
 (5) Nominal Tonnage is based on 3 gpm per ton at 95 degree entering water temperature, 85 degree leaving water temperature, and 78 degree wet-bulb temperature.

- ✦ Outlet connection extends 3/8" beyond bottom flange.
- † Heaviest section is upper section.
- † Height includes fan guard which ships factory mounted.
- ✦ Please consult the factory for additional information regarding shipping and section weight changes.

THREE CELL



# AT/UT/USS

## ENGINEERING DATA & DIMENSIONS

### MODELS: AT/UT/USS 310-136 to 310-954

Three-Cell Cooling Towers

\*310-136 to 310-936  
(3) 8" Inlet  
(3) 8" Outlet

\*310-154 to 310-954  
(3) 10" Inlet  
(3) 10" Outlet

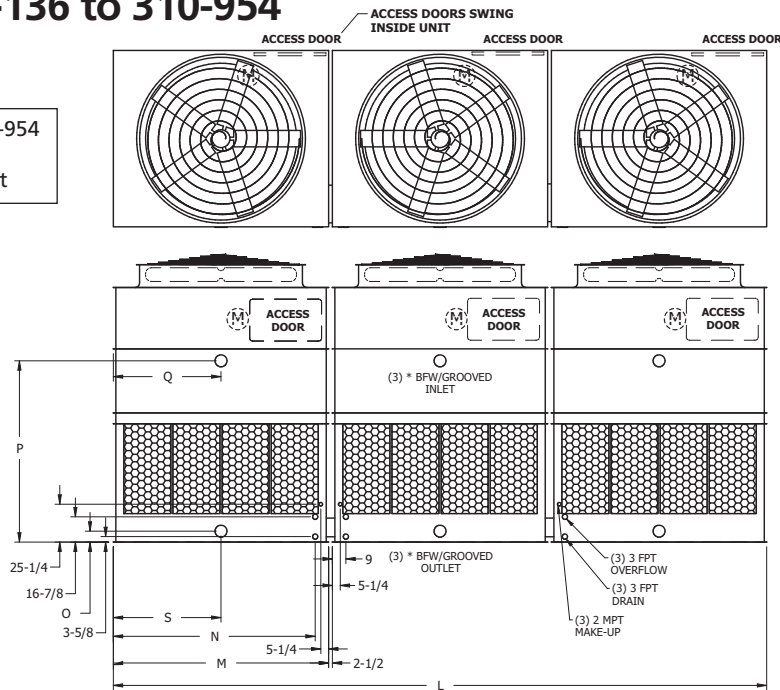
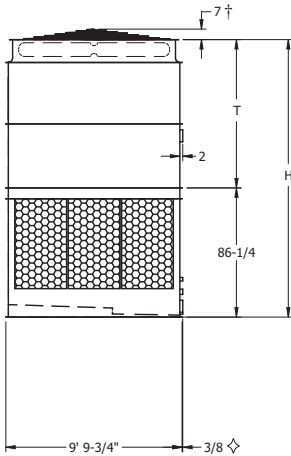

Model No.	Nominal Tonnage	Weights (LBS)			Fan Motor (HP)	Air Flow (CFM)	Dimensions							
		Shipping	Operating	Heaviest Section <sup>†</sup>			H <sup>†</sup>	T <sup>†</sup>	P	O	L	M	N	S&Q
AT 310-136L	782	21,030	37,650	4,750	(3) 10	191,200	16' 5-1/4"	9' 3"	11' 1"	7-1/4"	36' 4-1/4"	11' 11-3/4"	11' 2-3/4"	5' 11-7/8"
AT 310-136	914	21,030	37,650	4,750	(3) 15	217,200	16' 5-1/4"	9' 3"	11' 1"	7-1/4"	36' 4-1/4"	11' 11-3/4"	11' 2-3/4"	5' 11-7/8"
AT 310-236L	903	19,740	36,360	4,320	(3) 20	242,000	15' 5-1/4"	8' 3"	10' 1"	7-1/4"	36' 4-1/4"	11' 11-3/4"	11' 2-3/4"	5' 11-7/8"
AT 310-236	963	19,890	36,510	4,370	(3) 25	260,000	15' 5-1/4"	8' 3"	10' 1"	7-1/4"	36' 4-1/4"	11' 11-3/4"	11' 2-3/4"	5' 11-7/8"
AT 310-336	1,000	21,180	37,800	4,800	(3) 20	237,700	16' 5-1/4"	9' 3"	11' 1"	7-1/4"	36' 4-1/4"	11' 11-3/4"	11' 2-3/4"	5' 11-7/8"
AT 310-436	1,012	20,190	36,810	4,470	(3) 30	275,700	15' 5-1/4"	8' 3"	10' 1"	7-1/4"	36' 4-1/4"	11' 11-3/4"	11' 2-3/4"	5' 11-7/8"
AT 310-536	1,068	21,330	37,950	4,850	(3) 25	255,100	16' 5-1/4"	9' 3"	11' 1"	7-1/4"	36' 4-1/4"	11' 11-3/4"	11' 2-3/4"	5' 11-7/8"
AT 310-636L	1,038	22,440	39,060	5,220	(3) 20	234,000	17' 5-1/4"	10' 3"	12' 1"	7-1/4"	36' 4-1/4"	11' 11-3/4"	11' 2-3/4"	5' 11-7/8"
AT 310-636	1,106	22,590	39,210	5,270	(3) 25	251,300	17' 5-1/4"	10' 3"	12' 1"	7-1/4"	36' 4-1/4"	11' 11-3/4"	11' 2-3/4"	5' 11-7/8"
AT 310-736	1,126	21,630	38,250	4,950	(3) 30	270,400	16' 5-1/4"	9' 3"	11' 1"	7-1/4"	36' 4-1/4"	11' 11-3/4"	11' 2-3/4"	5' 11-7/8"
AT 310-836	1,164	22,890	39,510	5,370	(3) 30	265,900	17' 5-1/4"	10' 3"	12' 1"	7-1/4"	36' 4-1/4"	11' 11-3/4"	11' 2-3/4"	5' 11-7/8"
AT 310-936	1,216	23,640	40,260	5,620	(3) 35	279,100	17' 5-1/4"	10' 3"	12' 1"	7-1/4"	36' 4-1/4"	11' 11-3/4"	11' 2-3/4"	5' 11-7/8"
UT Addition		*	2,100	700			1' 9-1/2"	1' 9-1/2"						
AT 310-154L	1,040	27,120	52,340	5,710	(3) 15	293,700	15' 5-1/4"	8' 3"	10' 0"	8-1/2"	54' 5"	11' 2-3/4"	13' 2-3/4"	9' 0"
AT 310-154	1,154	27,270	52,490	5,760	(3) 20	322,300	15' 5-1/4"	8' 3"	10' 0"	8-1/2"	54' 5"	11' 2-3/4"	13' 2-3/4"	9' 0"
AT 310-254L	1,080	31,080	56,300	7,030	(3) 10	250,100	17' 5-1/4"	10' 3"	12' 0"	8-1/2"	54' 5"	11' 2-3/4"	13' 2-3/4"	9' 0"
AT 310-254	1,247	31,080	56,300	7,030	(3) 15	284,600	17' 5-1/4"	10' 3"	12' 0"	8-1/2"	54' 5"	11' 2-3/4"	13' 2-3/4"	9' 0"
AT 310-354L	1,173	29,190	54,410	6,400	(3) 15	289,300	16' 5-1/4"	9' 3"	11' 0"	8-1/2"	54' 5"	11' 2-3/4"	13' 2-3/4"	9' 0"
AT 310-354	1,296	29,340	54,560	6,450	(3) 20	317,000	16' 5-1/4"	9' 3"	11' 0"	8-1/2"	54' 5"	11' 2-3/4"	13' 2-3/4"	9' 0"
AT 310-454	1,320	27,720	52,940	5,910	(3) 30	366,800	15' 5-1/4"	8' 3"	10' 0"	8-1/2"	54' 5"	11' 2-3/4"	13' 2-3/4"	9' 0"
AT 310-554	1,398	29,490	54,710	6,500	(3) 25	340,100	16' 5-1/4"	9' 3"	11' 0"	8-1/2"	54' 5"	11' 2-3/4"	13' 2-3/4"	9' 0"
AT 310-654	1,481	29,790	55,010	6,600	(3) 30	360,000	16' 5-1/4"	9' 3"	11' 0"	8-1/2"	54' 5"	11' 2-3/4"	13' 2-3/4"	9' 0"
AT 310-754	1,552	31,680	56,900	7,230	(3) 30	354,300	17' 5-1/4"	10' 3"	12' 0"	8-1/2"	54' 5"	11' 2-3/4"	13' 2-3/4"	9' 0"
AT 310-854	1,624	30,540	55,760	6,850	(3) 40	394,100	16' 5-1/4"	9' 3"	11' 0"	8-1/2"	54' 5"	11' 2-3/4"	13' 2-3/4"	9' 0"
AT 310-954	1,694	32,430	57,650	7,480	(3) 40	387,800	17' 5-1/4"	10' 3"	12' 0"	8-1/2"	54' 5"	11' 2-3/4"	13' 2-3/4"	9' 0"
UT Addition		*	2,100	700			1' 9-1/2"	1' 9-1/2"						

NOTE: (1) An adequately sized bleed line must be installed in the cooling tower system to prevent build-up of impurities in the recirculated water.  
 (2) Do not use catalog drawings for certified prints. Dimensions and weights are subject to change.  
 (3) Adequate spacing must be allowed for access to the cooling tower. Refer to EVAPCO's Equipment Layout Manual.  
 (4) These models are available as (3) independent operating cells. Consult the factory for details.  
 (5) Nominal Tonnage is based on 3 gpm per ton at 95 degree entering water temperature, 85 degree leaving water temperature, and 78 degree wet-bulb temperature.

- ◇ Outlet connection extends 3/8" beyond bottom flange.
- ◆ Heaviest section is upper section.
- † Height does not include fan guard. Consult factory for whether or not fan guard ships mounted.
- ✦ Please consult the factory for additional information regarding shipping and section weight changes.



## ENGINEERING DATA & DIMENSIONS

### MODELS: AT/UT/USS 312-036 to 312-942

Three-Cell Cooling Towers

- \*312-036 to 312-936  
(3) 8" Inlets  
(3) 8" Outlets
- \*312-042 to 312-942  
(3) 10" Inlets  
(3) 10" Outlets

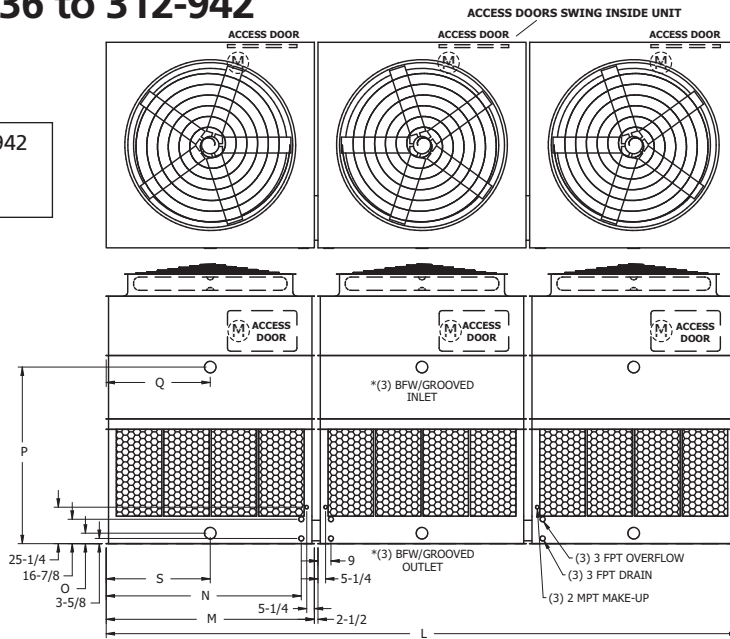
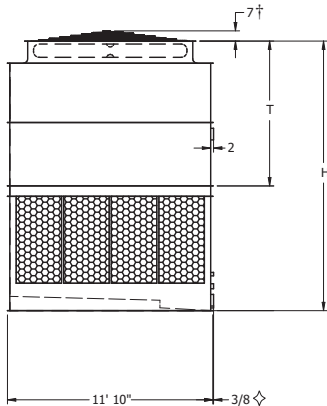

Model No.	Nominal Tonnage	Weights (LBS)			Fan Motor (HP)	Air Flow (CFM)	Dimensions							
		Shipping	Operating	Heaviest Section <sup>†</sup>			H <sup>†</sup>	T <sup>†</sup>	P	O	L	M	N	S&Q
AT 312-036L	1,014	22,110	40,740	5,000	(3) 15	246,400	15' 6-1/4"	8' 4"	10' 2"	7-1/4"	36' 4-1/4"	11' 11-3/4"	11' 2-3/4"	5' 11-7/8"
AT 312-036	1,106	22,260	40,890	5,050	(3) 20	270,400	15' 6-1/4"	8' 4"	10' 2"	7-1/4"	36' 4-1/4"	11' 11-3/4"	11' 2-3/4"	5' 11-7/8"
AT 312-136L	960	23,520	42,150	5,470	(3) 10	213,500	16' 6-1/4"	9' 4"	11' 2"	7-1/4"	36' 4-1/4"	11' 11-3/4"	11' 2-3/4"	5' 11-7/8"
AT 312-136	1,122	23,730	42,360	5,540	(3) 15	242,600	16' 6-1/4"	9' 4"	11' 2"	7-1/4"	36' 4-1/4"	11' 11-3/4"	11' 2-3/4"	5' 11-7/8"
AT 312-236	1,187	22,410	41,040	5,100	(3) 25	290,000	15' 6-1/4"	8' 4"	10' 2"	7-1/4"	36' 4-1/4"	11' 11-3/4"	11' 2-3/4"	5' 11-7/8"
AT 312-336	1,224	23,880	42,510	5,590	(3) 20	265,500	16' 6-1/4"	9' 4"	11' 2"	7-1/4"	36' 4-1/4"	11' 11-3/4"	11' 2-3/4"	5' 11-7/8"
AT 312-436L	1,174	25,200	43,830	6,030	(3) 15	238,500	17' 6-1/4"	10' 4"	12' 2"	7-1/4"	36' 4-1/4"	11' 11-3/4"	11' 2-3/4"	5' 11-7/8"
AT 312-436	1,277	25,350	43,980	6,080	(3) 20	261,400	17' 6-1/4"	10' 4"	12' 2"	7-1/4"	36' 4-1/4"	11' 11-3/4"	11' 2-3/4"	5' 11-7/8"
AT 312-536	1,316	24,030	42,660	5,640	(3) 25	284,700	16' 6-1/4"	9' 4"	11' 2"	7-1/4"	36' 4-1/4"	11' 11-3/4"	11' 2-3/4"	5' 11-7/8"
AT 312-636	1,375	25,500	44,130	6,130	(3) 25	280,100	17' 6-1/4"	10' 4"	12' 2"	7-1/4"	36' 4-1/4"	11' 11-3/4"	11' 2-3/4"	5' 11-7/8"
AT 312-736	1,398	24,330	42,960	5,740	(3) 30	301,300	16' 6-1/4"	9' 4"	11' 2"	7-1/4"	36' 4-1/4"	11' 11-3/4"	11' 2-3/4"	5' 11-7/8"
AT 312-836	1,458	25,800	44,430	6,230	(3) 30	296,400	17' 6-1/4"	10' 4"	12' 2"	7-1/4"	36' 4-1/4"	11' 11-3/4"	11' 2-3/4"	5' 11-7/8"
AT 312-936	1,560	26,550	45,180	6,480	(3) 40	324,500	17' 6-1/4"	10' 4"	12' 2"	7-1/4"	36' 4-1/4"	11' 11-3/4"	11' 2-3/4"	5' 11-7/8"
UT Addition		✦	2,100	700			1' 9-1/2"	1' 9-1/2"						
AT 312-042L	1,045	26,580	48,570	6,020	(3) 10	231,900	17' 6-1/4"	9' 4"	12' 1"	8-1/2"	42' 4-1/4"	13' 11-3/4"	13' 2-3/4"	9' 0"
AT 312-042	1,229	26,790	48,780	6,090	(3) 15	263,400	17' 6-1/4"	9' 4"	12' 1"	8-1/2"	42' 4-1/4"	13' 11-3/4"	13' 2-3/4"	9' 0"
AT 312-142L	1,195	24,990	46,980	5,490	(3) 20	293,600	16' 6-1/4"	8' 4"	11' 1"	8-1/2"	42' 4-1/4"	13' 11-3/4"	13' 2-3/4"	9' 0"
AT 312-142	1,289	25,170	47,160	5,550	(3) 25	315,200	16' 6-1/4"	8' 4"	11' 1"	8-1/2"	42' 4-1/4"	13' 11-3/4"	13' 2-3/4"	9' 0"
AT 312-242L	1,123	28,140	50,130	6,540	(3) 10	227,900	18' 6-1/4"	10' 4"	13' 1"	8-1/2"	42' 4-1/4"	13' 11-3/4"	13' 2-3/4"	9' 0"
AT 312-242	1,293	28,350	50,340	6,610	(3) 15	259,100	18' 6-1/4"	10' 4"	13' 1"	8-1/2"	42' 4-1/4"	13' 11-3/4"	13' 2-3/4"	9' 0"
AT 312-342	1,330	26,970	48,960	6,150	(3) 20	288,500	17' 6-1/4"	9' 4"	12' 1"	8-1/2"	42' 4-1/4"	13' 11-3/4"	13' 2-3/4"	9' 0"
AT 312-442	1,428	27,150	49,140	6,210	(3) 25	309,500	17' 6-1/4"	9' 4"	12' 1"	8-1/2"	42' 4-1/4"	13' 11-3/4"	13' 2-3/4"	9' 0"
AT 312-542	1,495	28,710	50,700	6,730	(3) 25	304,600	18' 6-1/4"	10' 4"	13' 1"	8-1/2"	42' 4-1/4"	13' 11-3/4"	13' 2-3/4"	9' 0"
AT 312-642	1,519	27,360	49,350	6,280	(3) 30	327,600	17' 6-1/4"	9' 4"	12' 1"	8-1/2"	42' 4-1/4"	13' 11-3/4"	13' 2-3/4"	9' 0"
AT 312-742	1,589	28,920	50,910	6,800	(3) 30	322,400	18' 6-1/4"	10' 4"	13' 1"	8-1/2"	42' 4-1/4"	13' 11-3/4"	13' 2-3/4"	9' 0"
AT 312-842	1,662	28,140	50,130	6,540	(3) 40	359,100	17' 6-1/4"	9' 4"	12' 1"	8-1/2"	42' 4-1/4"	13' 11-3/4"	13' 2-3/4"	9' 0"
AT 312-942	1,738	29,700	51,690	7,060	(3) 40	352,800	18' 6-1/4"	10' 4"	13' 1"	8-1/2"	42' 4-1/4"	13' 11-3/4"	13' 2-3/4"	9' 0"
UT Addition		✦	2,100	700			1' 9-1/2"	1' 9-1/2"						

- NOTE: (1) An adequately sized bleed line must be installed in the cooling tower system to prevent build-up of impurities in the recirculated water.  
 (2) Do not use catalog drawings for certified prints. Dimensions and weights are subject to change.  
 (3) Adequate spacing must be allowed for access to the cooling tower. Refer to EVAPCO's Equipment Layout Manual.  
 (4) These models are available as (3) independent operating cells. Consult the factory for details.  
 (5) Nominal Tonnage is based on 3 gpm per ton at 95 degree entering water temperature, 85 degree leaving water temperature, and 78 degree wet-bulb temperature.

- ✦ Outlet connection extends 3/8" beyond bottom flange.
- † Heaviest section is upper section.
- † Height does not include fan guard. Consult factory for whether or not fan guard ships mounted.
- ✦ Please consult the factory for additional information regarding shipping and section weight changes.

THREE CELL





# AT/UT/USS

## ENGINEERING DATA & DIMENSIONS

### MODELS: AT/UT/USS 312-054 to 312-960

Three-Cell Cooling Towers

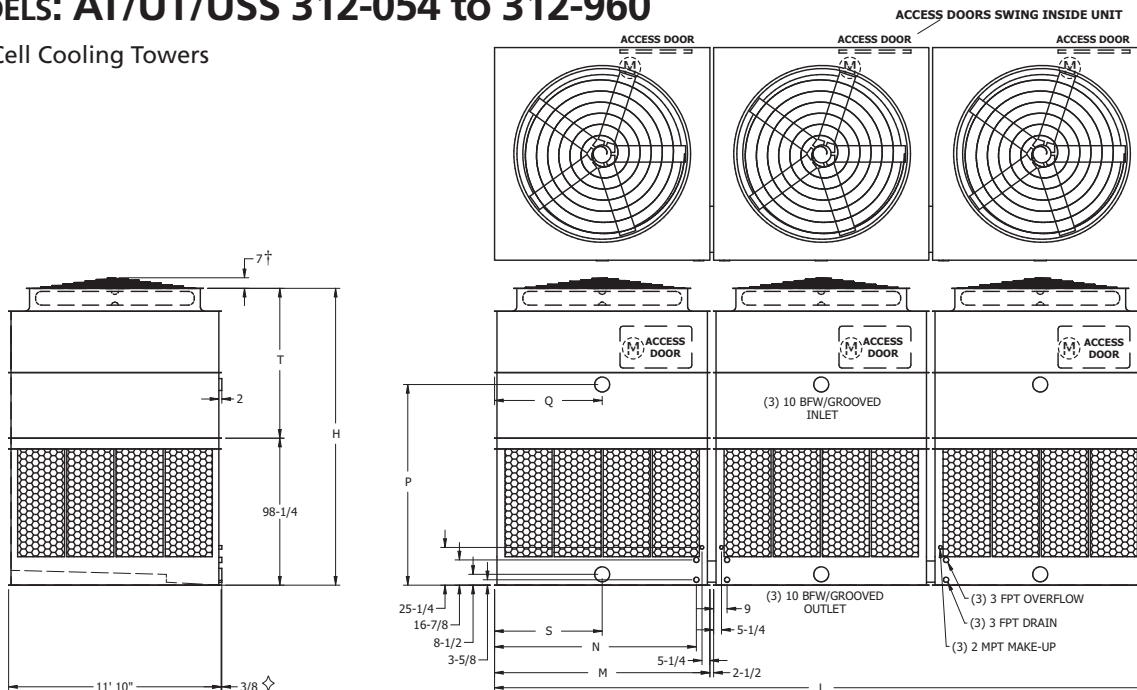

Model No.	Nominal Tonnage	Weights (LBS)			Fan Motor (HP)	Air Flow (CFM)	Dimensions						
		Shipping	Operating	Heaviest Section †			H †	T †	P	L	M	N	S&Q
AT 312-054L	1,586	31,950	59,760	6,810	(3) 25	389,000	16' 6-1/4"	8' 4"	11' 1"	54' 5"	11' 0"	17' 3"	9' 0"
AT 312-054	1,670	32,280	60,090	6,920	(3) 30	412,300	16' 6-1/4"	8' 4"	11' 1"	54' 5"	11' 0"	17' 3"	9' 0"
AT 312-154L	1,648	34,140	61,950	7,540	(3) 20	356,200	17' 6-1/4"	9' 4"	12' 1"	54' 5"	11' 0"	17' 3"	9' 0"
AT 312-154	1,752	34,290	62,100	7,590	(3) 25	382,300	17' 6-1/4"	9' 4"	12' 1"	54' 5"	11' 0"	17' 3"	9' 0"
AT 312-254	1,840	33,060	60,870	7,180	(3) 40	451,700	16' 6-1/4"	8' 4"	11' 1"	54' 5"	11' 0"	17' 3"	9' 0"
AT 312-354	1,851	34,620	62,430	7,700	(3) 30	405,300	17' 6-1/4"	9' 4"	12' 1"	54' 5"	11' 0"	17' 3"	9' 0"
AT 312-454L	1,828	36,510	64,320	8,330	(3) 25	376,300	18' 6-1/4"	10' 4"	13' 1"	54' 5"	11' 0"	17' 3"	9' 0"
AT 312-454	1,935	36,840	64,650	8,440	(3) 30	398,900	18' 6-1/4"	10' 4"	13' 1"	54' 5"	11' 0"	17' 3"	9' 0"
AT 312-554	2,036	35,400	63,210	7,960	(3) 40	443,500	17' 6-1/4"	9' 4"	12' 1"	54' 5"	11' 0"	17' 3"	9' 0"
AT 312-654	2,124	37,620	65,430	8,700	(3) 40	436,200	18' 6-1/4"	10' 4"	13' 1"	54' 5"	11' 0"	17' 3"	9' 0"
AT 312-754	2,182	35,580	63,390	8,020	(3) 50	475,900	17' 6-1/4"	9' 4"	12' 1"	54' 5"	11' 0"	17' 3"	9' 0"
AT 312-854	2,281	37,800	65,610	8,760	(3) 50	467,400	18' 6-1/4"	10' 4"	13' 1"	54' 5"	11' 0"	17' 3"	9' 0"
AT 312-954	2,367	38,130	65,940	8,870	(3) 60	495,100	18' 6-1/4"	10' 4"	13' 1"	54' 5"	11' 0"	17' 3"	9' 0"
UT Addition		♣	3,600	1,200			1' 3-1/2"	1' 3-1/2"					
AT 312-260L	1,600	36,150	67,350	7,940	(3) 20	363,700	17' 6-1/4"	9' 4"	12' 1"	60' 5"	20' 0"	19' 3"	10' 0"
AT 312-260	1,745	36,300	67,500	7,990	(3) 25	390,100	17' 6-1/4"	9' 4"	12' 1"	60' 5"	20' 0"	19' 3"	10' 0"
AT 312-360L	1,707	38,850	70,050	8,840	(3) 20	357,600	18' 6-1/4"	10' 4"	13' 1"	60' 5"	20' 0"	19' 3"	10' 0"
AT 312-360	1,844	39,000	70,200	8,890	(3) 25	383,700	18' 6-1/4"	10' 4"	13' 1"	60' 5"	20' 0"	19' 3"	10' 0"
AT 312-460L	1,865	35,220	66,420	7,630	(3) 40	460,000	16' 6-1/4"	8' 4"	11' 1"	60' 5"	20' 0"	19' 3"	10' 0"
AT 312-460	2,023	35,400	66,600	7,690	(3) 50	493,600	16' 6-1/4"	8' 4"	11' 1"	60' 5"	20' 0"	19' 3"	10' 0"
AT 312-560	2,083	37,410	68,610	8,360	(3) 40	451,400	17' 6-1/4"	9' 4"	12' 1"	60' 5"	20' 0"	19' 3"	10' 0"
AT 312-660	2,174	40,110	71,310	9,260	(3) 40	444,400	18' 6-1/4"	10' 4"	13' 1"	60' 5"	20' 0"	19' 3"	10' 0"
AT 312-760	2,260	37,590	68,790	8,420	(3) 50	484,000	17' 6-1/4"	9' 4"	12' 1"	60' 5"	20' 0"	19' 3"	10' 0"
AT 312-860	2,352	40,290	71,490	9,320	(3) 50	476,100	18' 6-1/4"	10' 4"	13' 1"	60' 5"	20' 0"	19' 3"	10' 0"
AT 312-960	2,440	40,620	71,820	9,430	(3) 60	504,600	18' 6-1/4"	10' 4"	13' 1"	60' 5"	20' 0"	19' 3"	10' 0"
UT Addition		♣	3,600	1,200			1' 3-1/2"	1' 3-1/2"					

NOTE: (1) An adequately sized bleed line must be installed in the cooling tower system to prevent build-up of impurities in the recirculated water.

(2) Do not use catalog drawings for certified prints. Dimensions and weights are subject to change.

(3) Adequate spacing must be allowed for access to the cooling tower. Refer to EVAPCO's Equipment Layout Manual.

(4) These models are available as (3) independent operating cells. Consult the factory for details.

(5) Nominal Tonnage is based on 3 gpm per ton at 95 degree entering water temperature, 85 degree leaving water temperature, and 78 degree wet-bulb temperature.

⚡ Outlet connection extends 3/8" beyond bottom flange.

♣ Heaviest section is upper section.

† Height does not include fan guard. Consult factory for whether or not fan guard ships mounted.

♣ Please consult the factory for additional information regarding shipping and section weight changes.

## ENGINEERING DATA & DIMENSIONS

### MODELS: AT/UT/USS 314-0172 to 314-1272

Three-Cell Cooling Towers

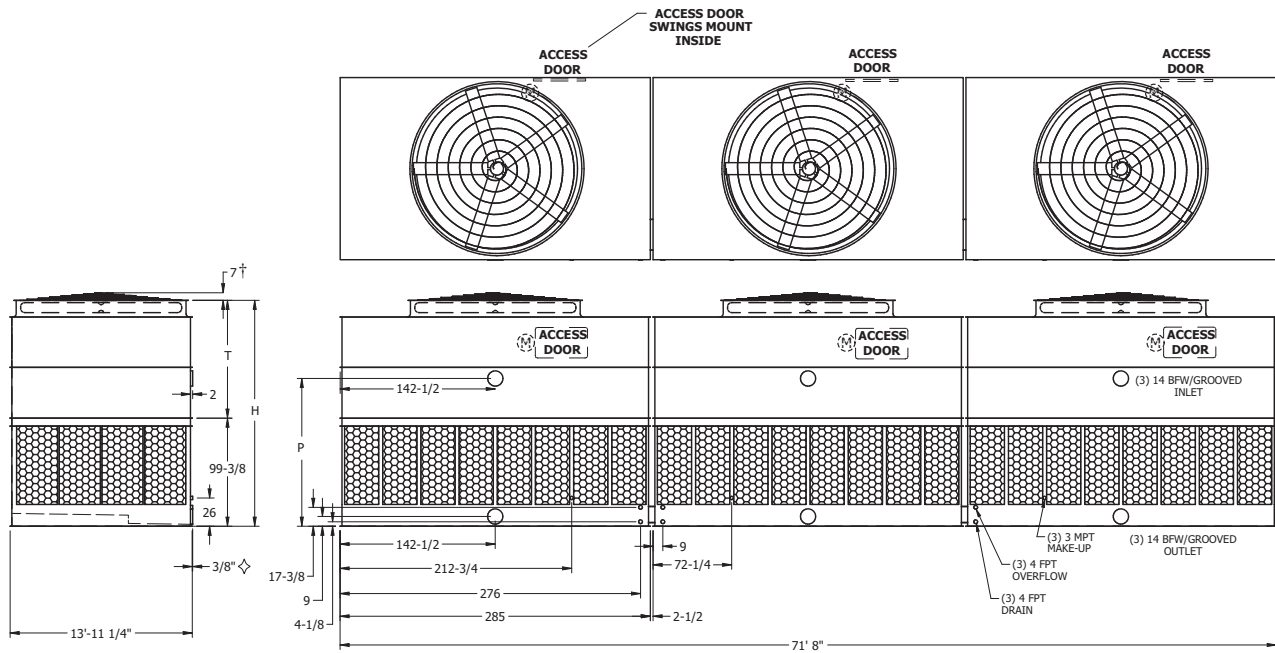

Model No.	Nominal Tonnage	Weights (LBS)			Fan Motor (HP)	Air Flow (CFM)	Dimensions		
		Shipping	Operating	Heaviest Section <sup>†</sup>			H <sup>†</sup>	T <sup>†</sup>	P
AT 314-0172L	1,986	53,490	101,040	10,650	(3) 25	499,900	17' 5-5/8"	9' 2-1/4"	11' 3-7/8"
AT 314-0172	2,095	53,550	101,100	10,670	(3) 30	530,100	17' 5-5/8"	9' 2-1/4"	11' 3-7/8"
AT 314-0272	2,271	54,000	101,550	10,820	(3) 40	580,900	17' 5-5/8"	9' 2-1/4"	11' 3-7/8"
AT 314-0372	2,439	55,050	102,600	11,170	(3) 50	624,200	17' 5-5/8"	9' 2-1/4"	11' 3-7/8"
AT 314-0472L	2,255	59,580	107,130	12,680	(3) 20	447,100	19' 5-5/8"	11' 2-1/4"	13' 3-7/8"
AT 314-0472	2,437	59,730	107,280	12,730	(3) 25	479,800	19' 5-5/8"	11' 2-1/4"	13' 3-7/8"
AT 314-0572	2,551	59,790	107,340	12,750	(3) 30	509,800	19' 5-5/8"	11' 2-1/4"	13' 3-7/8"
AT 314-0672L	2,364	56,670	104,220	11,710	(3) 30	521,300	18' 5-5/8"	10' 2-1/4"	12' 3-7/8"
AT 314-0672	2,601	57,120	104,670	11,860	(3) 40	570,700	18' 5-5/8"	10' 2-1/4"	12' 3-7/8"
AT 314-0772	2,773	58,170	105,720	12,210	(3) 50	613,000	18' 5-5/8"	10' 2-1/4"	12' 3-7/8"
AT 314-0872	2,770	60,240	107,790	12,900	(3) 40	561,200	19' 5-5/8"	11' 2-1/4"	13' 3-7/8"
AT 314-0972	2,919	61,290	108,840	13,250	(3) 50	602,700	19' 5-5/8"	11' 2-1/4"	13' 3-7/8"
AT 314-1072	2,944	58,680	106,230	12,380	(3) 60	648,600	18' 5-5/8"	10' 2-1/4"	12' 3-7/8"
AT 314-1172	3,091	61,800	109,350	13,420	(3) 60	638,300	19' 5-5/8"	11' 2-1/4"	13' 3-7/8"
AT 314-1272	3,322	62,520	110,070	13,660	(3) 75	699,700	19' 5-5/8"	11' 2-1/4"	13' 3-7/8"
UT Addition		✦	3,750	1,250			1' 1-1/2"	1' 1-1/2"	

- NOTE: (1) An adequately sized bleed line must be installed in the cooling tower system to prevent build-up of impurities in the recirculated water.  
 (2) Do not use catalog drawings for certified prints. Dimensions and weights are subject to change.  
 (3) Adequate spacing must be allowed for access to the cooling tower. Refer to EVAPCO's Equipment Layout Manual.  
 (4) These models are available as (3) independent operating cells. Consult the factory for details.  
 (5) Nominal Tonnage is based on 3 gpm per ton at 95 degree entering water temperature, 85 degree leaving water temperature, and 78 degree wet-bulb temperature.

- ✦ Outlet connection extends 3/8" beyond bottom flange.
- ✦ Heaviest section is upper section.
- † Height does not include fan guard. Consult factory for whether or not fan guard ships mounted.
- ✦ Please consult the factory for additional information regarding shipping and section weight changes.

THREE CELL





# AT/UT/USS

## ENGINEERING DATA & DIMENSIONS

### MODELS: AT/UT/USS 314-578 to 314-978

Three-Cell Cooling Towers

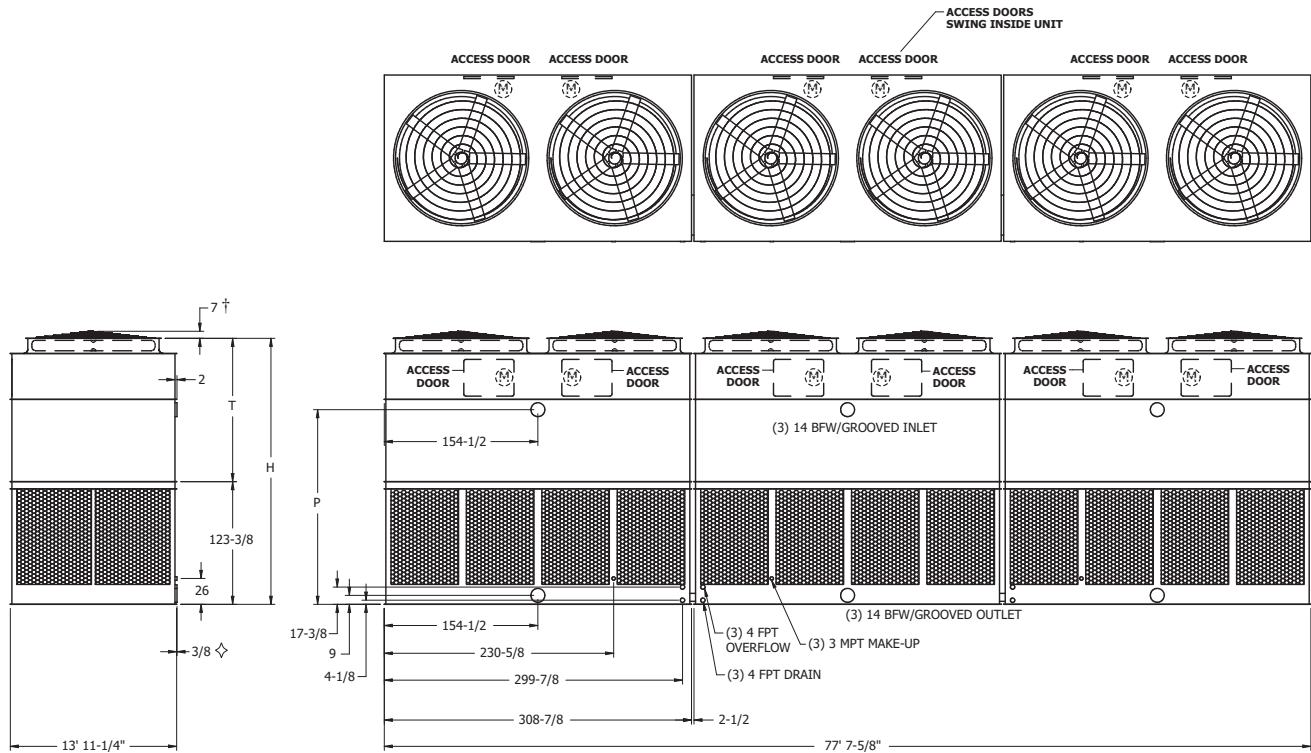

Model No.	Nominal Tonnage	Weights (LBS)			Fan Motor (HP)	Air Flow (CFM)	Dimensions		
		Shipping	Operating	Heaviest Section†			H†	T†	P
AT 314-578	2,936	73,620	124,110	17,660	(6)20	586,300	22' 3-1/2"	12' 1/8"	16' 3-3/4"
AT 314-678	3,157	73,800	124,290	17,720	(6)25	628,800	22' 3-1/2"	12' 1/8"	16' 3-3/4"
AT 314-778	3,344	74,100	124,590	17,820	(6)30	665,700	22' 3-1/2"	12' 1/8"	16' 3-3/4"
AT 314-878	3,655	75,060	125,550	18,140	(6)40	728,100	22' 3-1/2"	12' 1/8"	16' 3-3/4"
AT 314-978	3,908	75,120	125,610	18,160	(6)50	780,300	22' 3-1/2"	12' 1/8"	16' 3-3/4"
UT Addition		✦	7,200	✦			1' 3-1/2"	1' 3-1/2"	

NOTE: (1) An adequately sized bleed line must be installed in the cooling tower system to prevent build-up of impurities in the recirculated water.

(2) Do not use catalog drawings for certified prints. Dimensions and weights are subject to change.

(3) Adequate spacing must be allowed for access to the cooling tower. Refer to EVAPCO's Equipment Layout Manual.

(4) These models are available as (3) independent operating cells. Consult the factory for details.

(5) Nominal Tonnage is based on 3 gpm per ton at 95 degree entering water temperature, 85 degree leaving water temperature, and 78 degree wet-bulb temperature.

◇ Outlet connection extends 3/8" beyond bottom flange.

✦ Heaviest section is upper section.

† Height does not include fan guard. Consult factory for whether or not fan guard ships mounted.

✦ Please consult the factory for additional information regarding shipping and section weight changes.



## ENGINEERING DATA & DIMENSIONS

### MODELS: AT/UT/USS 342-526 to 342-926

Three-Cell Cooling Towers

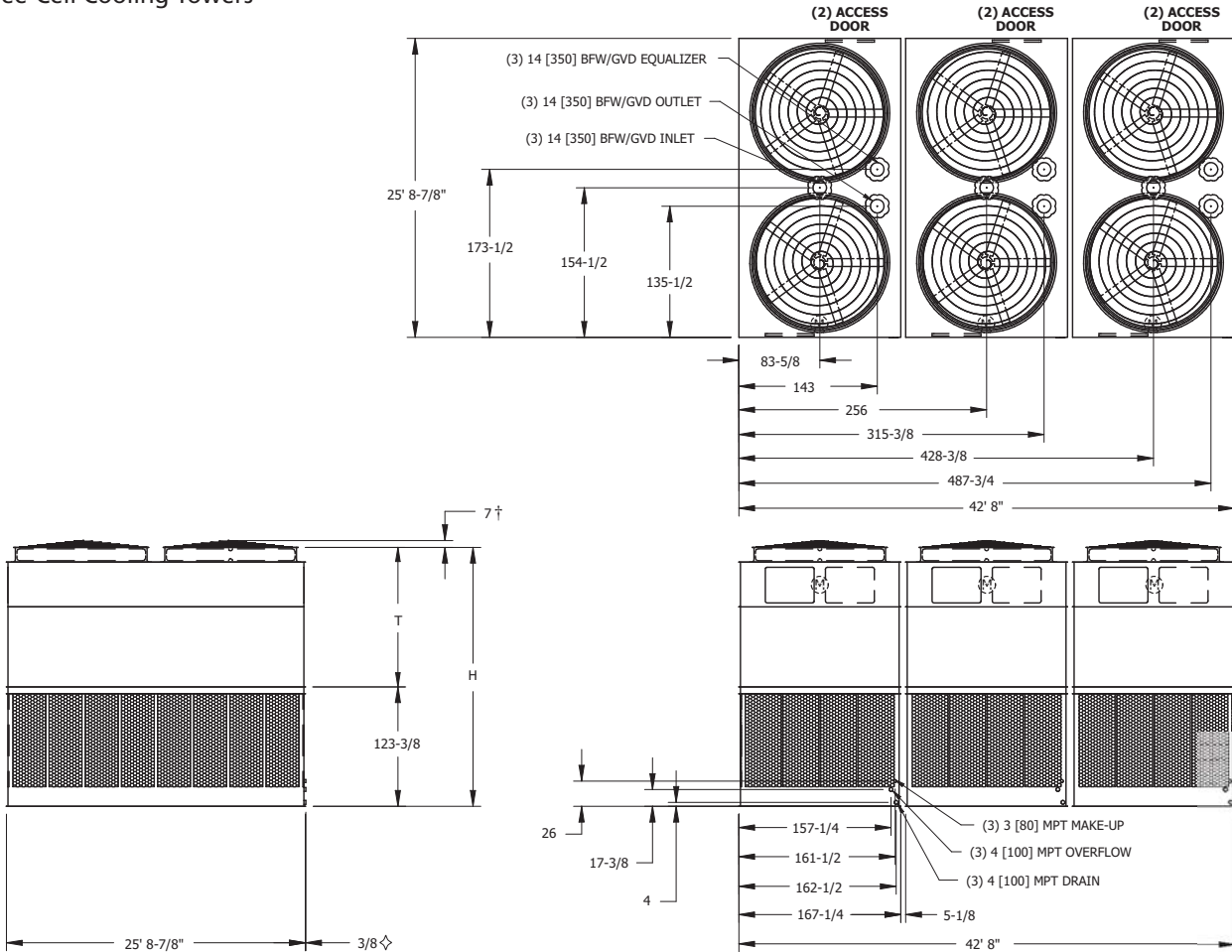

Model No.	Nominal Tonnage	Weights (LBS)			Fan Motor (HP)	Air Flow (CFM)	Dimensions		
		Shipping	Operating	Heaviest Section†			H†	T†	P
AT 342-526	2,882	73,410	222,700	17,660	(6)20	560,606	22' 3-1/2"	12' 1/8"	16' 3-3/4"
AT 342-626	3,100	73,590	222,880	17,720	(6)25	601,334	22' 3-1/2"	12' 1/8"	16' 3-3/4"
AT 342-726	3,286	73,890	223,180	17,820	(6)30	636,679	22' 3-1/2"	12' 1/8"	16' 3-3/4"
AT 342-826	3,593	74,850	224,140	18,140	(6)40	696,431	22' 3-1/2"	12' 1/8"	16' 3-3/4"
AT 342-926	3,844	74,910	224,200	18,160	(6)50	746,358	22' 3-1/2"	12' 1/8"	16' 3-3/4"
UT Addition		✦	7,200	✦			+1' 3-1/2"		

- NOTE: (1) An adequately sized bleed line must be installed in the cooling tower system to prevent build-up of impurities in the recirculated water.  
 (2) Do not use catalog drawings for certified prints. Dimensions and weights are subject to change.  
 (3) Adequate spacing must be allowed for access to the cooling tower. Refer to EVAPCO's Equipment Layout Manual.  
 (4) These models are available as (3) independent operating cells. Consult the factory for details.  
 (5) Nominal Tonnage is based on 3 gpm per ton at 95 degree entering water temperature, 85 degree leaving water temperature, and 78 degree wet-bulb temperature.

- ◇ Outlet connection extends 3/8" beyond bottom flange.
- ✦ Heaviest section is upper section.
- † Height does not include fan guard. Consult factory for whether or not fan guard ships mounted.
- ✦ Please consult the factory for additional information regarding shipping and section weight changes.

THREE CELL



# AT/UT/USS

## ENGINEERING DATA & DIMENSIONS

### MODELS: AT/UT/USS 420-124 to 420-936

Four-Cell Cooling Towers

\*420-124 to 420-924  
 (4) 8" Inlet  
 (2) 12" Outlet  
 (2) 3 MPT Overflow  
 (2) 2 MPT Make-Up  
 (2) 3 MPT Drain

\*420-136 to 420-936  
 (4) 10" Inlet  
 (4) 10" Outlet  
 (4) 3 MPT Overflow  
 (4) 2 MPT Make-Up  
 (4) 3 MPT Drain

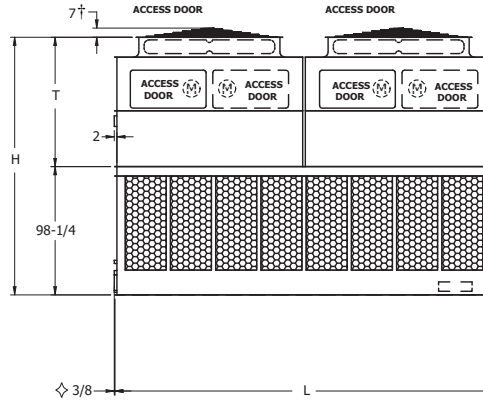
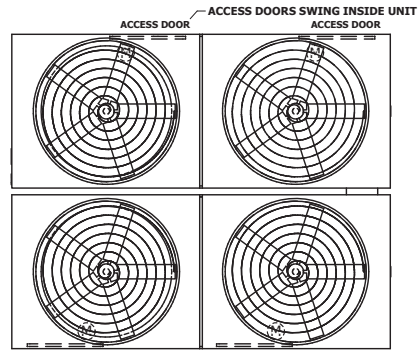
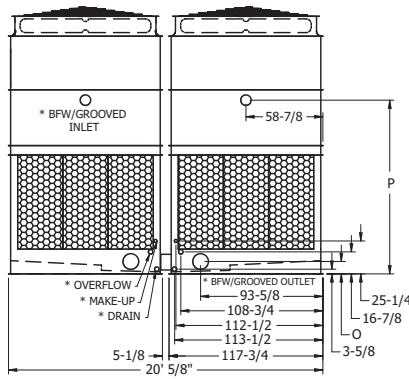

Model No.	Nominal Tonnage	Weights (LBS)			Fan Motor (HP)	Air Flow (CFM)	Dimensions				
		Shipping	Operating	Heaviest Section*			H†	T†	P	O	L
AT 420-124	1,229	27,700	49,840	U 4,750	(4) 15	286,500	17' 5 1/4"	9' 3"	12' 1"	9-1/2"	24' 1-3/4"
AT 420-224L	1,214	25,980	48,120	L 4,350	(4) 20	319,200	16' 5 1/4"	9' 3"	11' 1"	9-1/2"	24' 1-3/4"
AT 420-224	1,295	26,180	48,320	U 4,370	(4) 25	343,000	16' 5 1/4"	9' 3"	11' 1"	9-1/2"	24' 1-3/4"
AT 420-324	1,344	27,900	50,040	U 4,800	(4) 20	313,600	17' 5 1/4"	8' 3"	12' 1"	9-1/2"	24' 1-3/4"
AT 420-424	1,361	26,580	48,720	U 4,470	(4) 30	363,600	16' 5 1/4"	9' 3"	11' 1"	9-1/2"	24' 1-3/4"
AT 420-524	1,435	28,100	50,240	U 4,850	(4) 25	336,500	17' 5 1/4"	8' 3"	12' 1"	9-1/2"	24' 1-3/4"
AT 420-624L	1,394	29,580	51,720	U 5,250	(4) 20	308,700	18' 5 1/4"	10' 3"	13' 1"	9-1/2"	24' 1-3/4"
AT 420-624	1,485	29,780	51,920	U 5,270	(4) 25	331,400	18' 5 1/4"	10' 3"	13' 1"	9-1/2"	24' 1-3/4"
AT 420-724	1,513	28,500	50,640	U 4,950	(4) 30	356,600	17' 5 1/4"	8' 3"	12' 1"	9-1/2"	24' 1-3/4"
AT 420-824	1,563	30,180	52,320	U 5,370	(4) 30	350,900	18' 5 1/4"	10' 3"	13' 1"	9-1/2"	24' 1-3/4"
AT 420-924	1,632	31,180	53,320	U 5,620	(4) 35	368,000	18' 5 1/4"	10' 3"	13' 1"	9-1/2"	24' 1-3/4"
UT Addition		✦	2,800	✦			1' 9-1/2"	21-1/2"			
AT 420-136L	1,348	35,580	69,540	L 6,370	(4) 15	375,800	16' 5 1/4"	9' 3"	11'	8-1/2"	36' 2-1/2"
AT 420-136	1,496	35,780	69,740	L 6,370	(4) 20	412,300	16' 5 1/4"	9' 3"	11'	8-1/2"	36' 2-1/2"
AT 420-236L	1,408	40,860	74,820	U 7,030	(4) 10	319,900	18' 5 1/4"	10' 3"	13'	8-1/2"	36' 2-1/2"
AT 420-236	1,626	40,860	74,820	U 7,030	(4) 15	364,200	18' 5 1/4"	10' 3"	13'	8-1/2"	36' 2-1/2"
AT 420-336L	1,522	38,340	72,300	U 6,400	(4) 15	370,200	17' 5 1/4"	8' 3"	12'	8-1/2"	36' 2-1/2"
AT 420-336	1,686	38,540	72,500	U 6,450	(4) 20	405,800	17' 5 1/4"	8' 3"	12'	8-1/2"	36' 2-1/2"
AT 420-436	1,713	36,380	70,340	L 6,370	(4) 30	469,300	16' 5 1/4"	9' 3"	11'	8-1/2"	36' 2-1/2"
AT 420-536	1,820	38,740	72,700	U 6,500	(4) 25	435,200	17' 5 1/4"	8' 3"	12'	8-1/2"	36' 2-1/2"
AT 420-636	1,928	39,140	73,100	U 6,600	(4) 30	460,900	17' 5 1/4"	8' 3"	12'	8-1/2"	36' 2-1/2"
AT 420-736	2,025	41,660	75,620	U 7,230	(4) 30	453,400	18' 5 1/4"	10' 3"	13'	8-1/2"	36' 2-1/2"
AT 420-836	2,116	40,140	74,100	U 6,850	(4) 40	504,500	17' 5 1/4"	8' 3"	12'	8-1/2"	36' 2-1/2"
AT 420-936	2,212	42,660	76,620	U 7,480	(4) 40	496,200	18' 5 1/4"	10' 3"	13'	8-1/2"	36' 2-1/2"
UT Addition		✦	2,800	✦			1' 9-1/2"	1' 9-1/2"			

NOTE: (1) An adequately sized bleed line must be installed in the cooling tower system to prevent build-up of impurities in the recirculated water.  
 (2) Do not use catalog drawings for certified prints. Dimensions and weights are subject to change.  
 (3) Adequate spacing must be allowed for access to the cooling tower. Refer to EVAPCO's Equipment Layout Manual.  
 (4) These models are available as (4) independent operating cells. Consult the factory for details.  
 (5) Nominal Tonnage is based on 3 gpm per ton at 95 degree entering water temperature, 85 degree leaving water temperature, and 78 degree wet-bulb temperature.

- ✦ Outlet connection extends 3/8" beyond bottom flange.
- ✦ L = Lower Section, U = Upper Section
- † Height does not include fan guard. Consult factory for whether or not fan guard ships mounted.
- ✦ Please consult the factory for additional information regarding shipping and section weight changes.



## ENGINEERING DATA & DIMENSIONS

### MODELS: AT/UT/USS 424-024 to 424-924

Four-Cell Cooling Towers

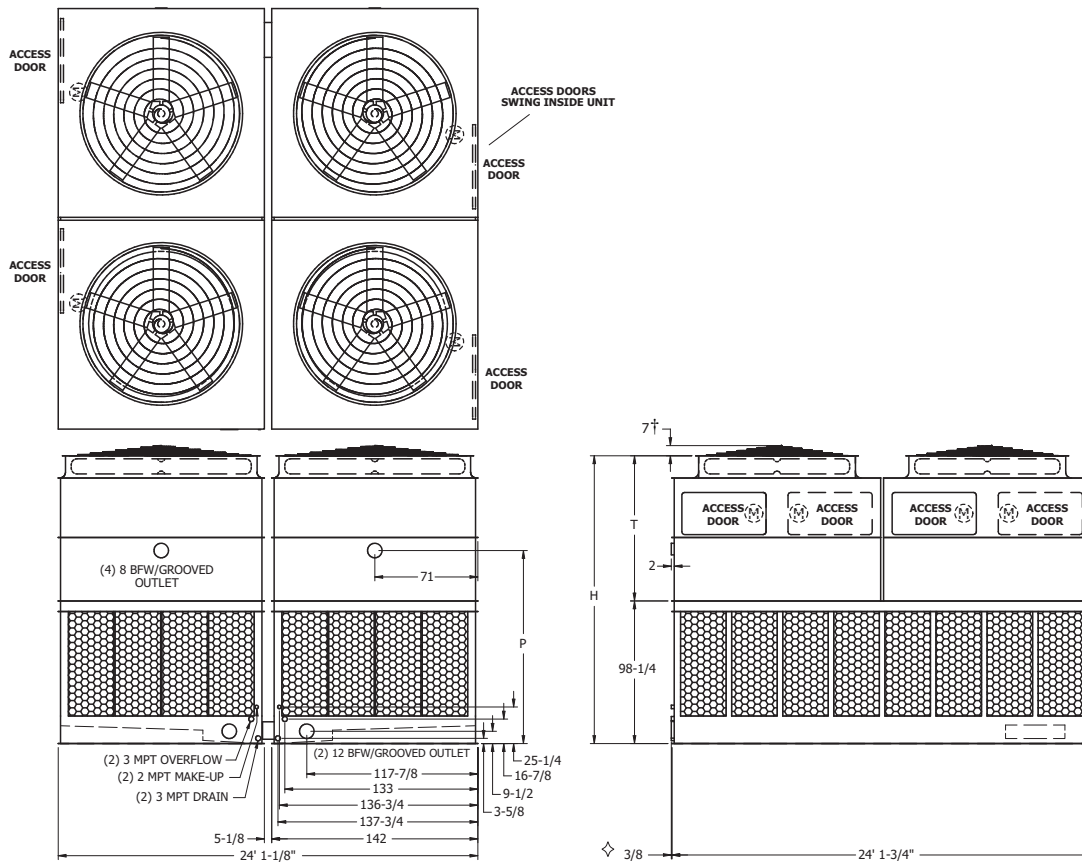

Model No.	Nominal Tonnage	Weights (LBS)			Fan Motor (HP)	Air Flow (CFM)	Dimensions		
		Shipping	Operating	Heaviest Section†			H†	T†	P
AT 424-024L	1,114	29,480	54,340	L 5,020	(4) 10	283,500	16' 6-1/4"	8' 4"	11' 2"
AT 424-024	1,327	30,040	54,900	L 5,020	(4) 15	322,300	16' 6-1/4"	8' 4"	11' 2"
AT 424-124	1,449	30,240	55,100	U 5,050	(4) 20	353,400	16' 6-1/4"	8' 4"	11' 2"
AT 424-224L	1,257	31,640	56,500	U 5,400	(4) 10	279,200	17' 6-1/4"	9' 4"	12' 2"
AT 424-224	1,471	32,200	57,060	U 5,540	(4) 15	317,000	17' 6-1/4"	9' 4"	12' 2"
AT 424-324	1,555	30,440	55,300	U 5,100	(4) 25	379,400	16' 6-1/4"	8' 4"	11' 2"
AT 424-424	1,605	32,400	57,260	U 5,590	(4) 20	347,400	17' 6-1/4"	9' 4"	12' 2"
AT 424-524	1,647	30,840	55,700	U 5,200	(4) 30	401,900	16' 6-1/4"	8' 4"	11' 2"
AT 424-624L	1,524	34,160	59,020	U 6,030	(4) 15	312,000	18' 6-1/4"	10' 4"	13' 2"
AT 424-624	1,678	34,360	59,220	U 6,080	(4) 20	341,900	18' 6-1/4"	10' 4"	13' 2"
AT 424-724	1,727	32,600	57,460	U 5,640	(4) 25	372,500	17' 6-1/4"	9' 4"	12' 2"
AT 424-824	1,835	33,000	57,860	U 5,740	(4) 30	394,400	17' 6-1/4"	9' 4"	12' 2"
AT 424-924	2,050	35,960	60,820	U 6,480	(4) 40	424,600	18' 6-1/4"	10' 4"	13' 2"
UT Addition		✦	2,800	✦			1' 9-1/2"	1' 9-1/2"	

- NOTE: (1) An adequately sized bleed line must be installed in the cooling tower system to prevent build-up of impurities in the recirculated water.  
 (2) Do not use catalog drawings for certified prints. Dimensions and weights are subject to change.  
 (3) Adequate spacing must be allowed for access to the cooling tower. Refer to EVAPCO's Equipment Layout Manual.  
 (4) These models are available as (4) independent operating cells. Consult the factory for details.  
 (5) Nominal Tonnage is based on 3 gpm per ton at 95 degree entering water temperature, 85 degree leaving water temperature, and 78 degree wet-bulb temperature.
- ◇ Outlet connection extends 3/8" beyond bottom flange.  
 † L = Lower Section, U = Upper Section  
 † Height does not include fan guard. Consult factory for whether or not fan guard ships mounted.  
 ✦ Please consult the factory for additional information regarding shipping and section weight changes.

FOUR CELL





# AT/UT/USS

## ENGINEERING DATA & DIMENSIONS

### MODELS: AT/UT/USS 424-028 to 424-928

Four-Cell Cooling Towers

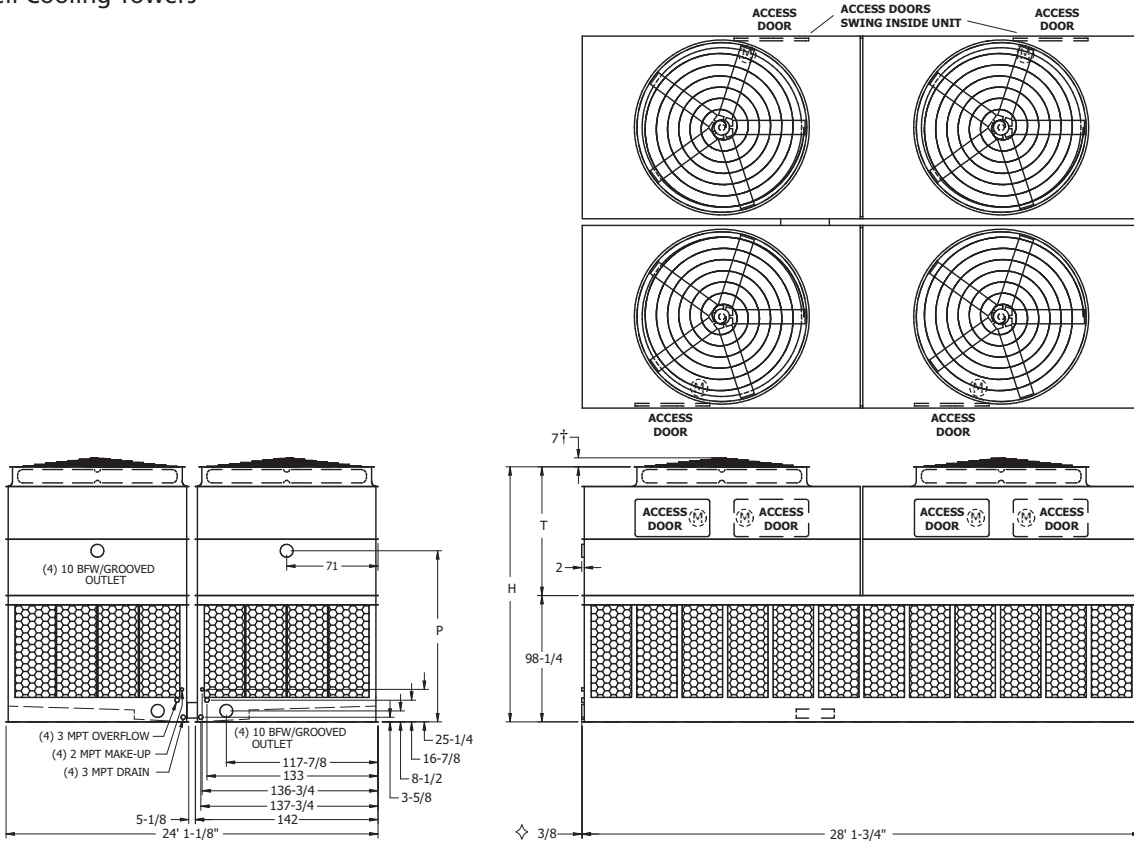

Model No.	Nominal Tonnage	Weights (LBS)			Fan Motor (HP)	Air Flow (CFM)	Dimensions		
		Shipping	Operating	Heaviest Section <sup>†</sup>			H <sup>†</sup>	T <sup>†</sup>	P
AT 424-028L	1,405	33,240	62,700	L 5,760	(4) 15	340,300	16' 6-1/4"	8' 4"	11' 1"
AT 424-028	1,564	33,480	62,940	L 5,760	(4) 20	372,900	16' 6-1/4"	8' 4"	11' 1"
AT 424-128L	1,434	37,400	66,860	U 6,470	(4) 10	289,800	18' 6-1/4"	10' 4"	13' 1"
AT 424-128	1,654	37,960	67,420	U 6,610	(4) 15	329,600	18' 6-1/4"	10' 4"	13' 1"
AT 424-228	1,689	33,720	63,180	L 5,760	(4) 25	400,300	16' 6-1/4"	8' 4"	11' 1"
AT 424-328L	1,563	35,880	65,340	U 6,090	(4) 15	335,100	17' 6-1/4"	9' 4"	12' 1"
AT 424-328	1,745	36,120	65,580	U 6,150	(4) 20	366,600	17' 6-1/4"	9' 4"	12' 1"
AT 424-428	1,833	38,200	67,660	U 6,670	(4) 20	360,700	18' 6-1/4"	10' 4"	13' 1"
AT 424-528	1,873	36,360	65,820	U 6,210	(4) 25	393,600	17' 6-1/4"	9' 4"	12' 1"
AT 424-628	1,965	38,440	67,900	U 6,730	(4) 25	387,300	18' 6-1/4"	10' 4"	13' 1"
AT 424-728	1,993	36,640	66,100	U 6,280	(4) 30	416,200	17' 6-1/4"	9' 4"	12' 1"
AT 424-828	2,088	38,720	68,180	U 6,800	(4) 30	409,900	18' 6-1/4"	10' 4"	13' 1"
AT 424-928	2,283	39,760	69,220	U 7,060	(4) 40	448,300	18' 6-1/4"	10' 4"	13' 1"
UT Addition		✦	2,800	✦			1' 9-1/2"	1' 9-1/2"	

- NOTE: (1) An adequately sized bleed line must be installed in the cooling tower system to prevent build-up of impurities in the recirculated water.  
 (2) Do not use catalog drawings for certified prints. Dimensions and weights are subject to change.  
 (3) Adequate spacing must be allowed for access to the cooling tower. Refer to EVAPCO's Equipment Layout Manual.  
 (4) These models are available as (2) independent operating cells. Consult the factory for details.  
 (5) Nominal Tonnage is based on 3 gpm per ton at 95 degree entering water temperature, 85 degree leaving water temperature, and 78 degree wet-bulb temperature.

- ◇ Outlet connection extends 3/8" beyond bottom flange.
- ✦ L = Lower Section, U = Upper Section
- † Height does not include fan guard. Consult factory for whether or not fan guard ships mounted.
- ✦ Please consult the factory for additional information regarding shipping and section weight changes.

# AT/UT/USS

## ENGINEERING DATA & DIMENSIONS

### MODELS: AT/UT/USS 424-036 to 424-936

Four-Cell Cooling Towers

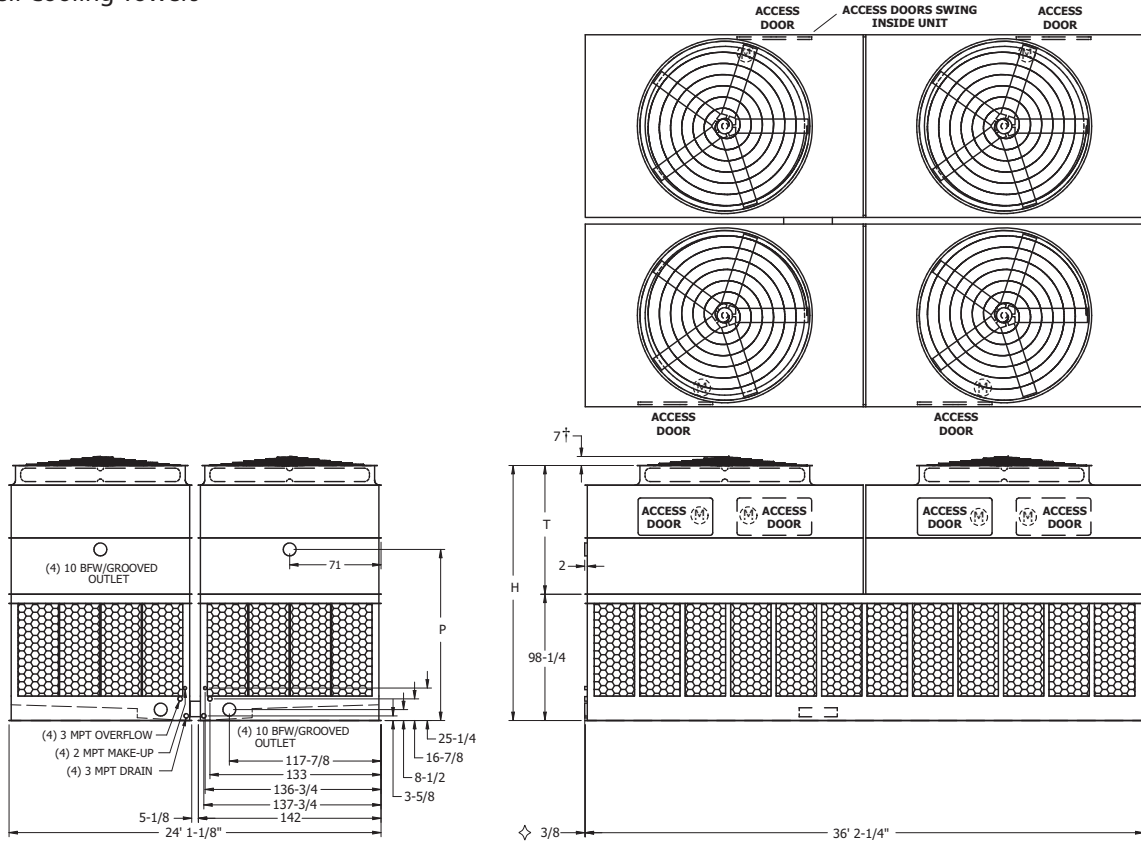

Model No.	Nominal Tonnage	Weights (LBS)			Fan Motor (HP)	Air Flow (CFM)	Dimensions		
		Shipping	Operating	Heaviest Section <sup>†</sup>			H <sup>†</sup>	T <sup>†</sup>	P
AT 424-036L	1,687	41,760	79,040	L 7,480	(4) 15	423,100	16' 6-1/4"	8' 4"	11' 1"
AT 424-036	1,914	42,000	79,280	L 7,480	(4) 20	463,300	16' 6-1/4"	8' 4"	11' 1"
AT 424-136	2,023	42,200	79,480	L 7,480	(4) 25	498,000	16' 6-1/4"	8' 4"	11' 1"
AT 424-236L	2,108	45,120	82,400	U 7,540	(4) 20	456,200	17' 6-1/4"	9' 4"	12' 1"
AT 424-236	2,246	45,320	82,600	U 7,590	(4) 25	489,600	17' 6-1/4"	9' 4"	12' 1"
AT 424-336	2,350	43,680	80,960	L 7,480	(4) 40	578,400	16' 6-1/4"	8' 4"	11' 1"
AT 424-436	2,373	45,760	83,040	U 7,700	(4) 30	519,200	17' 6-1/4"	9' 4"	12' 1"
AT 424-536L	2,353	48,280	85,560	U 8,330	(4) 25	481,900	18' 6-1/4"	10' 4"	13' 1"
AT 424-536	2,491	48,720	86,000	U 8,440	(4) 30	510,800	18' 6-1/4"	10' 4"	13' 1"
AT 424-636	2,614	46,800	84,080	U 7,960	(4) 40	567,900	17' 6-1/4"	9' 4"	12' 1"
AT 424-736	2,806	47,040	84,320	U 8,020	(4) 50	609,200	17' 6-1/4"	9' 4"	12' 1"
AT 424-836	2,938	50,000	87,280	U 8,760	(4) 50	598,800	18' 6-1/4"	10' 4"	13' 1"
AT 424-936	3,049	50,440	87,720	U 8,870	(4) 60	634,500	18' 6-1/4"	10' 4"	13' 1"
UT Addition		✱	4,800	✱			1' 3-1/2"	1' 3-1/2"	

NOTE: (1) An adequately sized bleed line must be installed in the cooling tower system to prevent build-up of impurities in the recirculated water.  
 (2) Do not use catalog drawings for certified prints. Dimensions and weights are subject to change.  
 (3) Adequate spacing must be allowed for access to the cooling tower. Refer to EVAPCO's Equipment Layout Manual.  
 (4) These models are available as (2) independent operating cells. Consult the factory for details.  
 (5) Nominal Tonnage is based on 3 gpm per ton at 95 degree entering water temperature, 85 degree leaving water temperature, and 78 degree wet-bulb temperature.

✧ Outlet connection extends 3/8" beyond bottom flange.  
 ✦ L = Lower Section, U = Upper Section  
 † Height does not include fan guard. Consult factory for whether or not fan guard ships mounted.  
 ✱ Please consult the factory for additional information regarding shipping and section weight changes.

FOUR CELL





# AT/UT/USS

## ENGINEERING DATA & DIMENSIONS

### MODELS: AT/UT/USS 428-0148 to 428-1348

Four-Cell Cooling Towers

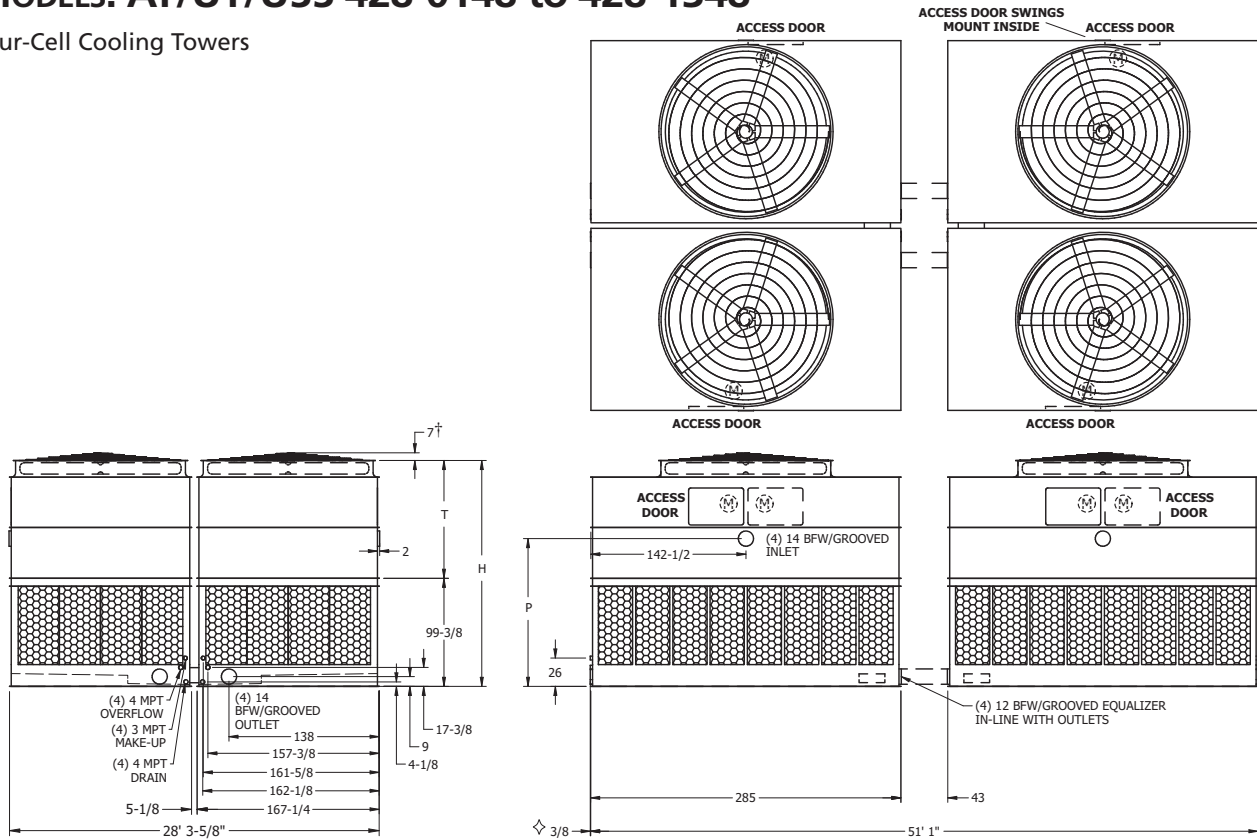

Model No.	Nominal Tonnage	Weights (LBS)			Fan Motor (HP)	Air Flow (CFM)	Dimensions		
		Shipping	Operating	Heaviest Section†			H†	T†	P
AT 428-0148L	2,482	65,480	128,880	10,650	(4) 25	646,400	17' 5-5/8"	9' 2-1/4"	11' 3-7/8"
AT 428-0148	2,626	65,560	128,960	10,670	(4) 30	685,500	17' 5-5/8"	9' 2-1/4"	11' 3-7/8"
AT 428-0248	2,846	66,160	129,560	10,820	(4) 40	752,000	17' 5-5/8"	9' 2-1/4"	11' 3-7/8"
AT 428-0348	3,067	67,560	130,960	11,170	(4) 50	807,000	17' 5-5/8"	9' 2-1/4"	11' 3-7/8"
AT 428-0448L	2,858	73,600	137,000	12,680	(4) 25	578,700	19' 5-5/8"	11' 2-1/4"	13' 3-7/8"
AT 428-0448	3,093	73,800	137,200	12,730	(4) 25	621,100	19' 5-5/8"	11' 2-1/4"	13' 3-7/8"
AT 428-0548	3,237	73,880	137,280	12,750	(4) 30	660,100	19' 5-5/8"	11' 2-1/4"	13' 3-7/8"
AT 428-0648L	2,984	69,720	133,120	11,710	(4) 30	675,000	18' 5-5/8"	10' 2-1/4"	12' 3-7/8"
AT 428-0648	3,283	70,320	133,720	11,860	(4) 40	739,200	18' 5-5/8"	10' 2-1/4"	12' 3-7/8"
AT 428-0748	3,509	71,720	135,120	12,210	(4) 50	793,000	18' 5-5/8"	10' 2-1/4"	12' 3-7/8"
AT 428-0848	3,524	74,480	137,880	12,900	(4) 40	726,500	19' 5-5/8"	11' 2-1/4"	13' 3-7/8"
AT 428-0948	3,714	75,880	139,280	13,250	(4) 50	780,200	19' 5-5/8"	11' 2-1/4"	13' 3-7/8"
AT 428-1048	3,728	72,400	135,800	12,380	(4) 60	840,300	18' 5-5/8"	10' 2-1/4"	12' 3-7/8"
AT 428-1148	3,933	76,560	139,960	13,420	(4) 60	826,200	19' 5-5/8"	11' 2-1/4"	13' 3-7/8"
AT 428-1248	4,229	77,520	140,920	13,660	(4) 75	904,900	19' 5-5/8"	11' 2-1/4"	13' 3-7/8"
AT 428-1348**	4,475	79,820	142,680	14,100	(4) 100	970,300	19' 5-5/8"	11' 2-1/4"	13' 3-7/8"
UT Addition		✦	5,000	1,250			1' 1-1/2"	1' 1-1/2"	

- NOTE: (1) An adequately sized bleed line must be installed in the cooling tower system to prevent build-up of impurities in the recirculated water.  
 (2) Do not use catalog drawings for certified prints. Dimensions and weights are subject to change.  
 (3) Adequate spacing must be allowed for access to the cooling tower. Refer to EVAPCO's Equipment Layout Manual.  
 (4) These models are available as (4) independent operating cells. Consult the factory for details.  
 (5) Nominal Tonnage is based on 3 gpm per ton at 95 degree entering water temperature, 85 degree leaving water temperature, and 78 degree wet-bulb temperature.

- ◇ Outlet connection extends 3/8" beyond bottom flange.
- ✦ Heaviest section is upper section.
- † Height does not include fan guard. Consult factory for whether or not fan guard ships mounted.
- ✦ Please consult the factory for additional information regarding shipping and section weight changes.

\*\* Model available with gear drive only. Motor and access door located on 13'11-1/4" unit end. Super Low Sound Fan is not available on this unit.

## ENGINEERING DATA & DIMENSIONS

### MODELS: AT/UT/USS 428-552 to 428-952

Four-Cell Cooling Towers

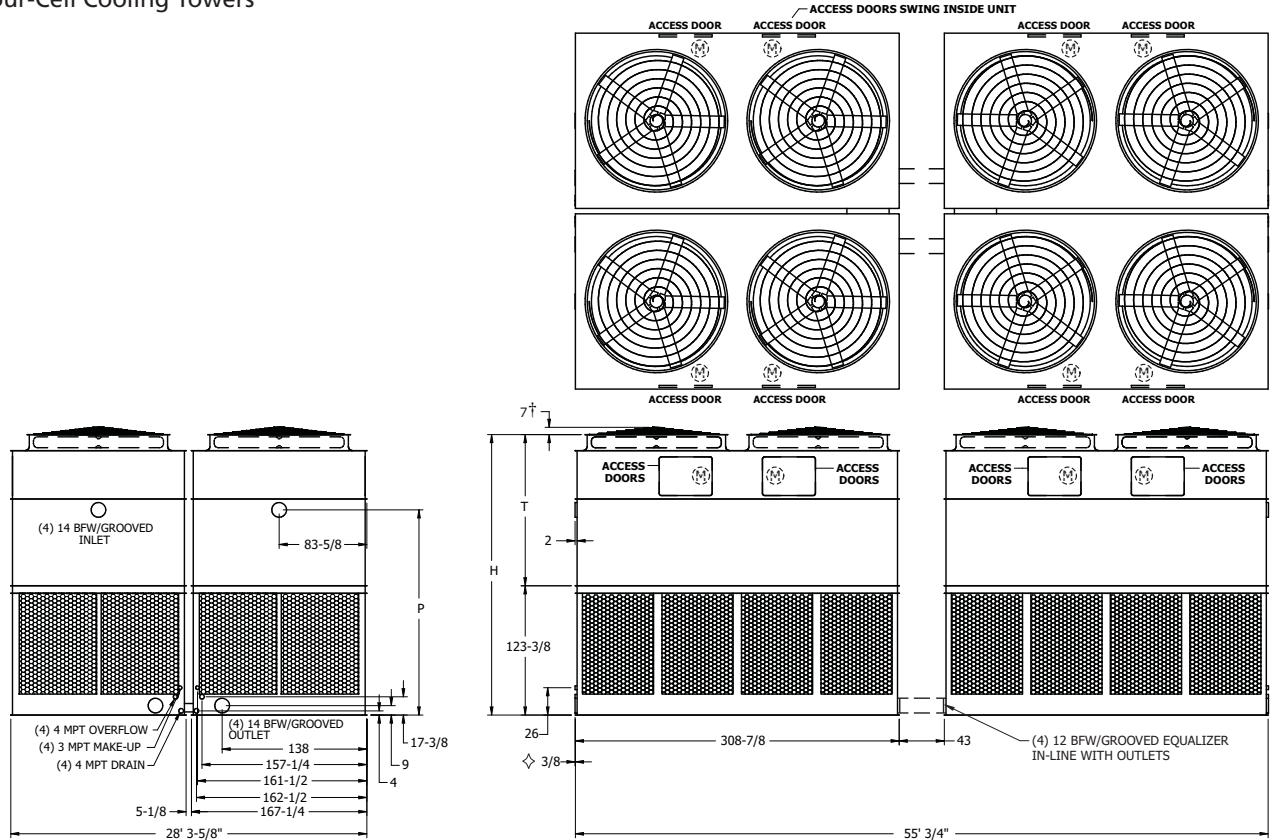

Model No.	Nominal Tonnage	Weights (LBS)			Fan Motor (HP)	Air Flow (CFM)	Dimensions		
		Shipping	Operating	Heaviest Section†			H†	T†	P
AT 428-552	3,857	97,960	165,280	17,660	(8)20	747,500	22' 3-1/2"	12' 1/8"	16' 3-3/4"
AT 428-652	4,148	98,200	165,520	17,720	(8)25	801,900	22' 3-1/2"	12' 1/8"	16' 3-3/4"
AT 428-752	4,395	98,600	165,920	17,820	(8)30	849,100	22' 3-1/2"	12' 1/8"	16' 3-3/4"
AT 428-852	4,806	99,880	167,200	18,140	(8)40	928,900	22' 3-1/2"	12' 1/8"	16' 3-3/4"
AT 428-952	5,141	99,960	167,280	18,160	(8)50	995,700	22' 3-1/2"	12' 1/8"	16' 3-3/4"
UT Addition		✦	9,600	✦			1' 3-1/2"	1' 3-1/2"	

- NOTE: (1) An adequately sized bleed line must be installed in the cooling tower system to prevent build-up of impurities in the recirculated water.  
 (2) Do not use catalog drawings for certified prints. Dimensions and weights are subject to change.  
 (3) Adequate spacing must be allowed for access to the cooling tower. Refer to EVAPCO's Equipment Layout Manual.  
 (4) These models are available as (4) independent operating cells. Consult the factory for details.  
 (5) Nominal Tonnage is based on 3 gpm per ton at 95 degree entering water temperature, 85 degree leaving water temperature, and 78 degree wet-bulb temperature.
- ◇ Outlet connection extends 3/8" beyond bottom flange.
  - ✦ Heaviest section is upper section.
  - † Height does not include fan guard. Consult factory for whether or not fan guard ships mounted.
  - ✦ Please consult the factory for additional information regarding shipping and section weight changes.

FOUR CELL





# AT/UT/USS

## ENGINEERING DATA & DIMENSIONS

### MODELS: AT/UT/USS 456-526 to 456-926

Four-Cell Cooling Towers

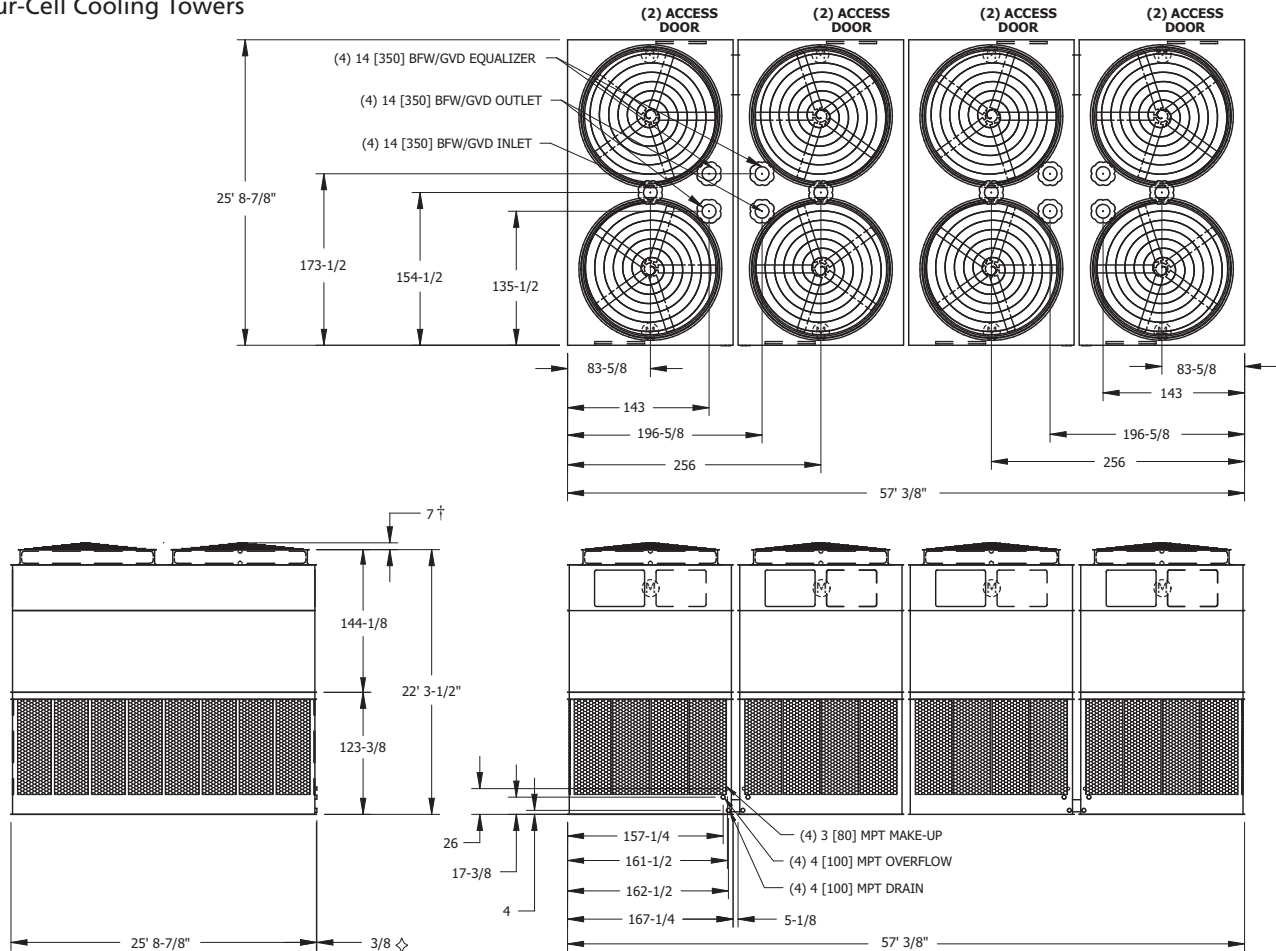

Model No.	Nominal Tonnage	Weights (LBS)			Fan Motor (HP)	Air Flow (CFM)	Dimensions		
		Shipping	Operating	Heaviest Section†			H†	T†	P
AT 456-526	3,802	97,880	323,280	17,660	(8)20	711,215	22' 3-1/2"	12' 1/8"	16' 3-3/4"
AT 456-626	4,090	98,120	323,520	17,720	(8)25	762,926	22' 3-1/2"	12' 1/8"	16' 3-3/4"
AT 456-726	4,335	98,520	323,920	17,820	(8)30	807,791	22' 3-1/2"	12' 1/8"	16' 3-3/4"
AT 456-826	4,743	99,800	325,200	18,140	(8)40	883,646	22' 3-1/2"	12' 1/8"	16' 3-3/4"
AT 456-926	5,075	99,880	325,280	18,160	(8)50	947,043	22' 3-1/2"	12' 1/8"	16' 3-3/4"
UT Addition		✦	9,600	✦			+1' 3-1/2"		

- NOTE: (1) An adequately sized bleed line must be installed in the cooling tower system to prevent build-up of impurities in the recirculated water.  
 (2) Do not use catalog drawings for certified prints. Dimensions and weights are subject to change.  
 (3) Adequate spacing must be allowed for access to the cooling tower. Refer to EVAPCO's Equipment Layout Manual.  
 (4) These models are available as (4) independent operating cells. Consult the factory for details.  
 (5) Nominal Tonnage is based on 3 gpm per ton at 95 degree entering water temperature, 85 degree leaving water temperature, and 78 degree wet-bulb temperature.

- ✦ Outlet connection extends 3/8" beyond bottom flange.  
 ✦ Heaviest section is upper section.  
 † Height does not include fan guard. Consult factory for whether or not fan guard ships mounted.  
 ✦ Please consult the factory for additional information regarding shipping and section weight changes.

# DRAIN DOWN VOLUME FOR REMOTE SUMP APPLICATIONS

# AT/UT/USS

## Drain Down Volume for Remote Sump Applications

The following chart provides the maximum drain down volume allowable per AT/UT/USS model number. Use this chart when sizing indoor or outdoor remote sumps tanks. Remote sump applications are commonly used whenever a cooling tower is idle during sub-freezing weather to protect the water in the basin from freezing or for large multi-tower industrial applications. Either application allows the circulating water to gravity drain into a remote sump tank indoors or a large, outdoor concrete basin located underneath the cooling tower.

The water volume provided is the cooling tower portion of the remote sump tank only. The tank should allow for drain down water from external piping and pump suction coverage.

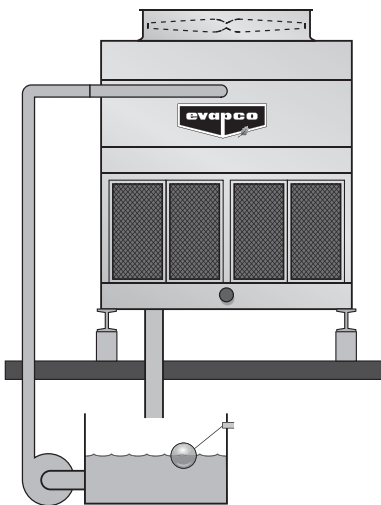

	Model No.	Maximum Drain Down Volume (gal.)
1 - CELL	14-64 to 14-94	85
	14-66 to 14-96	130
	14-69 to 14-99	195
	14-612 to 14-912	275
	19-56 to 19-96	270
	19-28 to 19-98	320
	19-59 to 19-99	395
	19-111 to 19-911	460
	19-412 to 19-912	525
	19-114 to 19-914	610
	110-112 to 110-912	645
	110-118 to 110-918	980
	112-012 to 112-912	720
	112-314 to 112-914	855

	Model No.	Maximum Drain Down Volume (gal.)
1 - CELL	112-018 to 112-918	1090
	112-520 to 112-920	1210
	114-0124 to 114-1324	1855
	114-526 to 114-926	2085
2 - CELL	26-517 to 26-917	540
	28-217 to 28-917	640
	212-59 to 212-99	540
	215-29 to 215-99	640
	217-59 to 217-99	790
	217-111 to 217-911	920
	217-412 to 217-912	1050
	217-214 to 217-914	1220
	29-318 to 29-918	790
	29-121 to 29-921	920
	29-024 to 29-924	1050
	29-228 to 29-928	1220
	210-124 to 210-924	1290
	210-136 to 210-936	1960
	212-024 to 212-924	1440
	212-128 to 212-928	1710
	212-036 to 212-936	2180
	214-0148 to 214-1248	3710
	214-552 to 214-952	4170
	220-112 to 220-912	1290
220-118 to 220-918	1960	
224-018 to 224-918	2180	
224-720 to 224-920	2420	
228-0124 to 228-1024	3710	
228-526 to 228-926	4170	
3 - CELL	39-336 to 39-936	1575
	39-242 to 39-942	1830
	310-136 to 310-936	1935
	310-154 to 310-954	2940
	312-036 to 312-936	2160
	312-042 to 312-942	2565
	312-054 to 312-954	3270
	312-260 to 312-960	3630
	314-0172 to 314-1272	5565
	314-578 to 314-978	6255
4 - CELL	342-526 to 342-926	6255
	420-124 to 420-924	2580
	420-136 to 420-936	3920
	424-024 to 424-924	2880
	424-028 to 424-928	3420
	424-036 to 424-936	4360
	428-0148 to 428-1348	7420
	428-552 to 428-952	8340
456-526 to 456-926	8340	





# AT/UT/USS

## MECHANICAL SPECIFICATIONS

### SECTION 23 65 00 – FACTORY-FABRICATED COOLING TOWERS

#### PART 1 – GENERAL

- 1.1 RELATED DOCUMENTS
  - A. Drawings and general provisions of the Contract, including General and Supplementary Conditions and Division 1 Specification Sections, apply to this section.
- 1.2 SUMMARY:
  - A. This Section includes factory assembled and tested, open circuit, induced draft counterflow cooling tower.
- 1.3 SUBMITTALS
  - A. General. Submit the following:
    - 1. Certified drawings of the cooling tower, sound data, recommended steel support indicating weight loadings, wiring diagrams, installation instructions, operation and maintenance instructions, and thermal performance guarantee by the manufacturer.
- 1.4 QUALITY ASSURANCE
  - A. Verification of Performance:
    - 1. Test and certify cooling tower thermal performance according to CTI Standard 201.
    - 2. Test and certify cooling tower sound performance according to CTI ATC-128.
  - B. Meet or Exceed energy efficiency per ASHRAE 90.1.
- 1.5 WARRANTY
  - A. Motor/Drive System: Five (5) year comprehensive warranty against materials and workmanship including motor, fan, bearings, mechanical support, sheaves, bushings and belt.
  - B. Unit (AT & UT): One (1) year from start-up, not to exceed eighteen (18) months from shipment on the unit.
  - C. Unit (USS): Five (5) year comprehensive warranty against materials and workmanship for complete unit.

#### PART 2 - PRODUCTS

- 2.1 MANUFACTURERS
  - A. Manufacturers: Subject to compliance with requirements, provide cooling towers manufactured by one of the following:
    - 1. EVAPCO, Inc.
    - 2. Approved Substitute
- 2.2 MATERIALS
  - A. Galvanized Sheet Steel having G-235 designation.
  - B. Optional Type 304 and/or 316 Stainless Steel as specified.
- 2.3 INDUCED-DRAFT, COUNTERFLOW COOLING TOWERS
  - A. Description: Factory assembled and tested, induced draft counterflow cooling tower complete with fill, fan, louvers, accessories, and rigging supports.
  - B. Cooling Tower Characteristics and Capacities: Refer to the Cooling Tower schedule.
  - C. Fan(s):
    - 1. Type and Material (AT & USS): Axial propeller, individually adjustable wide chord blade extruded aluminum installed in a closely fitted cowl with venturi air inlet for maximum efficiency, covered with a heavy gauge hot dipped Galvanized (AT) or Stainless Steel (USS) fan guard.
    - 2. Type and Material(UT): Axial propeller, one-piece heavy duty steel hub and FRP blade construction. Galvanized steel closely fitted fan cowl with venturi air inlet for maximum fan efficiency, covered with a heavy gauge hot dip galvanized steel fan guard. (Optional Type 304 stainless steel)
    - 3. Maximum sound pressure level of \_\_\_\_dB(A) measured at 5 feet above the fan discharge during full speed operation in accordance with CTI Standard ATC-128.
  - D. Water Distribution System: Non-corrosive materials.
    - 1. Evenly distribute of water over fill material with pressurized spray tree.
      - a. Pipes: Schedule 40 PVC, Non-corrosive Materials
      - b. Nozzles: Non-clogging, ABS Plastic, threaded into branch piping.
    - 2. Maximum pressure at inlet shall be \_\_\_\_ psig.

- E. IBC Compliance: The unit structure shall be designed, analyzed, and constructed in accordance with the latest edition of the International Building Code (IBC) Regulations for seismic loads up to \_\_\_\_ g and wind loads up to \_\_\_\_ psf.
  - F. Collection Basin Material: (AT/UT ) Galvanized Steel; (USS) Type 304 or 316 Stainless Steel.
    - 1. Removable stainless-steel strainer with openings smaller than nozzle orifices.
    - 2. Joints: Bolted and sealed watertight or welded.
    - 3. Overflow, makeup and side drain connections
    - 4. Flume plate between cells (for multiple-cell units) or Equalizer connection (for multiple-cooling-tower system).
  - G. Casing: (AT/UT ) Galvanized Steel; (USS) Type 304 or 316 Stainless Steel:
    - 1. Casing panels shall totally encase the fill media to protect the fill from damage due to direct atmospheric contact.
    - 2. Fasteners: Corrosion resistance equal to or better than materials being fastened.
    - 3. Joints: Sealed watertight.
    - 4. Welded Connections: Continuous and watertight
  - H. Fill Media: PVC; resistant to rot, decay and biological attack; formed, crossfluted bonded together for strength and durability in block format for easy removal and replacement; suitable for use as a working surface; self extinguishing with flame spread rating of 5 per ASTM E84-81a; able to withstand continuous operating temperature of 130°F; and fabricated, formed and installed by the manufacturer to ensure water breaks up into droplets.
  - I. Drift Eliminators: Same material as Fill. 0.001% drift rate.
  - J. Air Inlet Louver Screens: Formed PVC mounted in steel frames constructed of the same material as the basin for easy removal; designed "Water Sight Tight" to completely block direct sunlight from entering and water from splashing out of the cooling tower.
  - K. Water Level Control: Brass mechanical makeup water valve and plastic float with an adjustable linkage. (Optional Electronic Water Level Control available. EWLC has slow closing solenoid valve, wye strainer and optional high and low water level alarms.)
- 2.4 MOTORS AND DRIVES
    - A. General requirements for motors are specified in Division 15 Section "Motors".
    - B. Enclosure Type: TEAO or TEFC
    - C. Motor Speed: Single Speed reversible (Option: VFD Duty, 2-speed)
    - D. Drive: Power Band Belt designed for 150% of the motor nameplate HP.
      - 1. Belt: One-piece Mutli-groove, solid back V-belt type neoprene reinforced with polyester cord.
      - 2. Sheaves: Aluminum alloy if located inside the airstream.
      - 3. Bearings: Heavy duty, self-aligning pillow block bearings with lubrication lines extended to side access door. Minimum L10 life for bearings shall be 75,000 hours. Provide extended grease lines and fittings.
      - 4. Vibration Cutout Switch: Mechanical switch to de-energize fan motors if excessive vibration in NEMA 4 enclosure.
  - 2.5 MAINTENANCE ACCESS
    - A. Internal Working / Service Platforms: Provide a complete internal working platform and ladder system for service of all drive components. A suitable working platform may be constructed of the fill media for counterflow cooling towers. If a crossflow tower is used, provide an internal walkway with ladder and elevated working platform to allow for service and maintenance to motor and drive assembly.
    - B. Handrails/Grabrails: Galvanized steel pipe complying with 29 CFR 1910.23. If access to fan deck is required, supply a perimeter handrail with ladder from grade to fan deck.
    - C. Ladders: Aluminum, sloped "ships type" with grabrail or vertical complying with 29 CFR 1910.27.

## APPLICATIONS

### Design

EVAPCO Cooling towers are of heavy-duty construction and designed for long trouble-free operation. Proper equipment selection, installation and maintenance are necessary to ensure full unit performance while maximizing the equipment's service life. Some of the major considerations in the application of a tower are presented below. For additional information, please contact the factory.

### Piping

Cooling tower piping should be designed and installed in accordance with generally accepted engineering practices. All piping should be anchored by properly designed hangers and supports with allowance made for possible expansion and contraction. No external loads should be placed upon cooling tower connections, nor should any of the piping supports be anchored to the unit framework.

The piping connection locations shown on the drawings included in this catalog and on the website are standard locations that can be changed. If the piping connection locations shown do not meet the needs of a particular project, contact the factory to determine a viable solution.

### Air Circulation

In reviewing the system design and unit location, it is important that enough fresh air is provided to enable proper unit performance. The best location is on an unobstructed roof top or at ground level away from walls and other barriers. Care must be taken when locating towers in wells or enclosures or next to high walls. The potential for recirculation of the hot, moist discharge air back into the fan intake exists. Recirculation raises the wetbulb temperature of the entering air, causing the leaving water temperature to rise above the design conditions. For these cases, the overall unit height should be raised so it is even with the adjacent wall, reducing the chance of recirculation. This can be done by raising the entire unit or adding a discharge hood. For additional information, see the EVAPCO Equipment Layout Manual. Engineering Assistance is also available from the factory to identify potential recirculation problems and recommend solutions, such as re-orienting multi-cell units.

### Design Flexibility and Assistance

The large number of EVAPCO AT Cooling towers makes it easy to find a model to meet your design and layout needs. If there is an application for which the standard catalog product line does not work, EVAPCO will make a cooling tower that will fit your requirement. Consult your local EVAPCO Representative or the factory for assistance with Applications, Layout, Accessories or other design needs.

### Water Treatment

Proper water treatment is an essential part of the maintenance required for all evaporative cooling equipment. A well designed and consistently implemented water treatment program will help to ensure efficient system operation while maximizing the equipment's service life. A qualified water

treatment company should design a site specific water treatment protocol based on equipment (including all metallurgies in the cooling system), location, makeup water quality and usage.

Without proper water treatment, the equipment can be susceptible to scale build-up on its heat exchange surfaces, biological growth in the recirculating water and corrosion of its components. Your site specific water treatment protocol should include procedures for routine operation, startup after a shut-down period, and system lay-up, if applicable.

### Passivation Period

If the equipment includes any galvanized components, the initial commissioning and passivation period is a critical time for maximizing the service life of galvanized equipment. Evapco recommends that a site specific water treatment protocol which includes a passivation procedure that details the desired water chemistry and visual inspections during the first six to twelve weeks of operation be used. During this passivation period, recirculating water pH should be maintained above 7.0 and below 8.0 at all times.

### Recirculating Water System

The cooling in a tower is accomplished by the evaporation of a portion of the recirculated spray water. As this water evaporates, it leaves behind mineral content and impurities. Therefore, it is important to bleed-off an amount of water proportional to that which is evaporated to prevent the buildup of impurities. If this is not done, the mineral content and/or the corrosive nature of the water will continue to increase. This can ultimately result in heavy scaling or a corrosive condition.

### Bleed-off

Evaporative cooling equipment requires a bleed or blow-down line to remove concentrated water from the system. The mineral concentration is monitored by measuring the conductivity of the water. Evapco recommends an automated conductivity controller to maximize the water efficiency of your system. Based on recommendations from your water treatment supplier, the conductivity controller should open and close a bleed valve to maintain the conductivity of the recirculating water.

### Control of Biological Contaminants

Evaporative cooling equipment should be inspected regularly to ensure good microbiological control. Inspections should include both monitoring of microbial populations via culturing techniques and visual inspections for evidence of biofouling. Poor microbiological control can result in loss of heat transfer efficiency, increase corrosion potential, and increase the risk of pathogens such as those that can cause risk to health. If excessive microbiological contamination is detected, a more aggressive mechanical cleaning and/or water treatment program should be undertaken.





# AT/UT/USS

## STRUCTURAL STEEL SUPPORT

### Models AT/UT/USS 14-64 to 314-978

#### Suggested Two I-Beam Arrangement

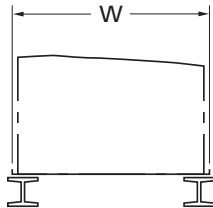

End Elevation

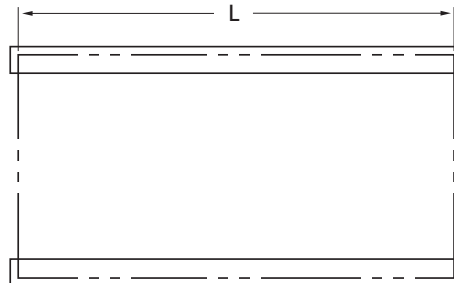

Plan View

#### Models AT & USS 14-64 through 110-918

Two I-Beams Required (By Others)

#### Models AT & USS 210-124 through 314-978

Two I-Beams Required (By Others)

		Dimensions		
		Model No.	W	L
1-CELL		14-64 to 14-94	4' 0-15/32"	3' 11-5/8"
		14-66 to 14-96	4' 0-15/32"	5' 11-5/8"
		14-69 to 14-99	4' 0-15/32"	8' 11-11/16"
		14-612 to 14-912	4' 0-15/32"	11' 11-5/8"
		19-56 to 19-96	5' 11-7/8"	8' 5-1/2"
		19-28 to 19-98	7' 5-7/8"	8' 5-1/2"
		19-59 to 19-99	8' 5-1/2"	8' 11-1/2"
		19-111 to 19-911	8' 5-1/2"	10' 5-1/2"
		19-412 to 19-912	8' 5-1/2"	11' 11-3/4"
		19-114 to 19-914	8' 5-1/2"	13' 11-3/4"
		110-112 to 110-912	9' 9-3/4"	11' 11-3/4"
		110-118 to 110-918	9' 9-3/4"	18' 0"
		112-012 to 112-912	11' 10"	11' 11-3/4"
		112-314 to 112-914	11' 10"	13' 11-3/4"
2-CELL		112-018 to 112-918	11' 10"	18' 0"
		112-520 to 112-920	11' 10"	20' 0"
		114-0124 to 114-1324	13' 11-1/4"	23' 9"
		114-526 to 114-926	13' 11-1/4"	25' 8-7/8"
		26-517 to 26-917	5' 11-7/8"	17' 1-1/2"
		28-217 to 28-917	7' 5-7/8"	17' 1-1/2"
		29-318 to 29-918	8' 5-1/2"	18' 0"

		Dimensions		
		Model No.	W	L
2-CELL		29-121 to 29-921	8' 5-1/2"	21' 0"
		29-024 to 29-924	8' 5-1/2"	24' 2"
		29-228 to 29-928	8' 5-1/2"	28' 2"
		210-124 to 210-924	9' 9-3/4"	21' 0"
		210-136 to 210-936	9' 9-3/4"	36' 2-1/2"
		212-024 to 212-924	11' 10"	24' 2"
		212-128 to 212-928	11' 10"	28' 2"
		212-036 to 212-936	11' 10"	36' 2-1/2"
		214-0148 to 214-1248	13' 11-1/4"	47' 8-1/2"
		214-552 to 214-952	13' 11-1/4"	51' 8-1/4"
3-CELL		39-336 to 39-936	8' 5-1/2"	36' 4-1/4"
		39-242 to 39-942	8' 5-1/2"	42' 4-1/4"
		310-136 to 310-936	9' 9-3/4"	36' 4-1/4"
		310-154 to 310-954	9' 9-3/4"	54' 5"
		312-036 to 312-936	11' 10"	36' 4-1/4"
		312-042 to 312-942	11' 10"	42' 4-1/4"
		312-054 to 312-954	11' 10"	54' 5"
		312-260 to 312-960	11' 10"	60' 5"
		314-0172 to 314-1272	13' 11-1/4"	71' 8"
		314-578 to 314-978	13' 11-1/4"	77' 7-5/8"

#### Notes:

Models Listed Above.

1. These are suggested arrangements for preliminary layout purposes. Consult your EVAPCO representative for factory certified steel support drawings.
2. The recommended support for the AT/UT/USS Cooling Tower is structural I-beams located under the outer flanges and running the entire length of the unit. The unit should be elevated to allow access underneath the unit and to the roof below. Mounting holes, 3/4" in diameter, are located in the bottom flanges of the pan to provide for bolting to the structural steel.
3. Beams should be sized in accordance with accepted structural practices. Maximum deflection of beam under unit to be 1/360 of the unit length, not to exceed 1/2".
4. For these models where two support beams are required, deflection may be calculated by using 55% of the operating weight as a uniform load on each beam.
5. Beams should be level before setting the unit in place. Do not level the unit by shimming between it and the I-beams.
6. Support beams and Anchor bolts are to be furnished by others.
7. Dimensions, weights and data are subject to change without notice. Refer to the factory certified drawings for exact dimensions.
8. For alternate layout arrangements please consult the factory. *NOTE: OPTIONAL BOTTOM CONNECTIONS WILL REQUIRE THE UNIT TO BE ELEVATED TO ALLOW FOR PIPING.*

## STRUCTURAL STEEL SUPPORT

### Models AT/UT/USS 212-59 to 428-952

#### Suggested Three I-Beam Arrangement

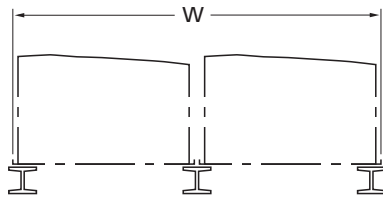

End Elevation

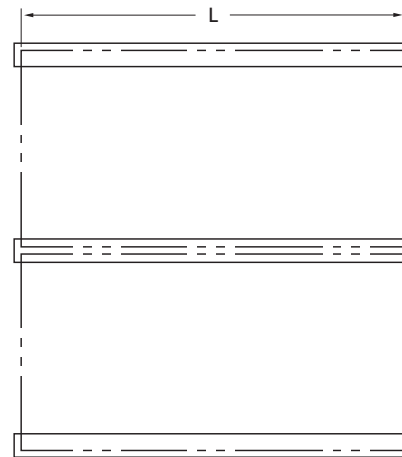

Plan View

#### Models AT/UT/USS 212-59 through 428-952

Three I-Beams Required (By Others)

Dimensions			
Model No.	W	L	
2-CELL	212-59 to 212-99	12' 4-7/8"	8' 5-1/2"
	215-29 to 215-99	15' 4-7/8"	8' 5-1/2"
	217-59 to 217-99	17' 4-3/4"	8' 11-1/2"
	217-111 to 217-911	17' 4-1/8"	10' 5-1/2"
	217-412 to 217-912	17' 4-1/8"	11' 11-3/4"
	217-214 to 217-914	17' 4-1/8"	13' 11-3/4"
	220-112 to 220-912	20' 0-5/8"	11' 11-3/4"
	220-118 to 220-918	20' 0-5/8"	18' 0"
	224-018 to 224-918	24' 1-1/8"	18' 0"
	224-720 to 224-920	24' 1-1/8"	20' 0"
	228-0124 to 228-1024	28' 3-5/8"	23' 9"
	228-526 to 228-926	28' 3-5/8"	25' 8-7/8"
4-CELL	420-124 to 420-924	20' 0-5/8"	24' 1-3/4"
	420-136 to 420-936	20' 0-5/8"	36' 2-1/4"
	424-024 to 424-924	24' 1-1/8"	24' 1-3/4"
	424-028 to 424-928	24' 1-1/8"	28' 1-3/4"
	424-036 to 424-936	24' 1-1/8"	36' 2-1/4"
	428-0148 to 428-1348	28' 3-5/8"	51' 1"
428-552 to 428-952	28' 3-5/8"	55' 0-3/4"	

**Notes:**

Models Listed Above.

1. These are suggested arrangements for preliminary layout purposes. Consult your EVAPCO representative for factory certified steel support drawings.
2. The recommended support for the AT/UT/USS Cooling Tower is structural I-beams located under the outer flanges and running the entire length of the unit. The unit should be elevated to allow access underneath the unit and to the roof below. Mounting holes, 3/4" in diameter are located in the bottom flanges of the pan to provide for bolting to the structural steel.
3. Beams should be sized in accordance with accepted structural practices. Maximum deflection of beam under unit to be 1/360 of the unit length, not to exceed 1/2".
4. For these models only where three support beams are required, deflection may be calculated using 56% of the operating weight on the CENTER BEAM and 22% on each OUTBOARD beam.
5. Beams should be level before setting the unit in place. Do not level the unit by shimming between it and the I-beams.
6. Support beams and Anchor bolts are to be furnished by others.
7. Dimensions, weights and data are subject to change without notice. Refer to the factory certified drawings for exact dimensions.
8. For alternate layout arrangements please consult the factory. *NOTE: OPTIONAL BOTTOM CONNECTIONS WILL REQUIRE THE UNIT TO BE ELEVATED TO ALLOW FOR PIPING.*





# AT/UT/USS

## STRUCTURAL STEEL SUPPORT

### Models AT/UT/USS 342-526 to 456-926

#### Suggested I-Beam Arrangement

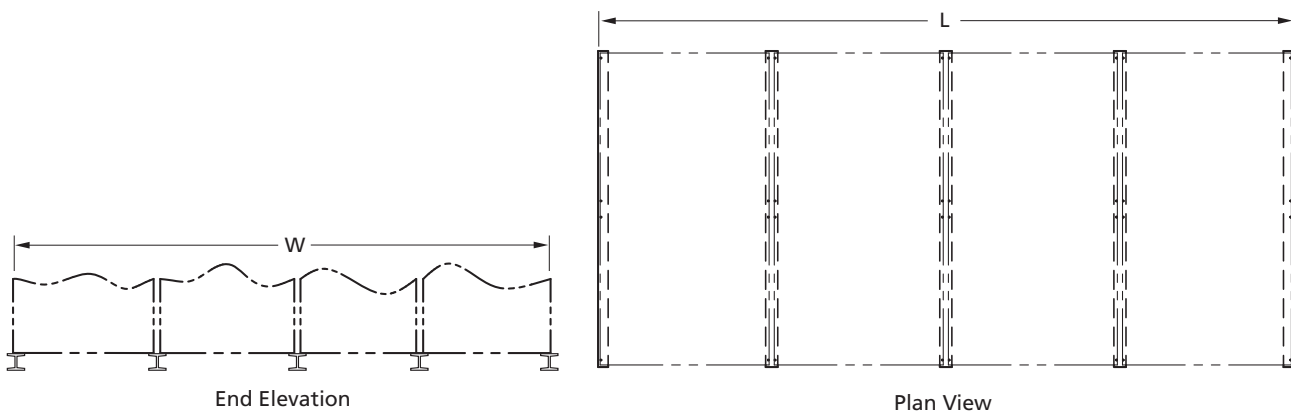
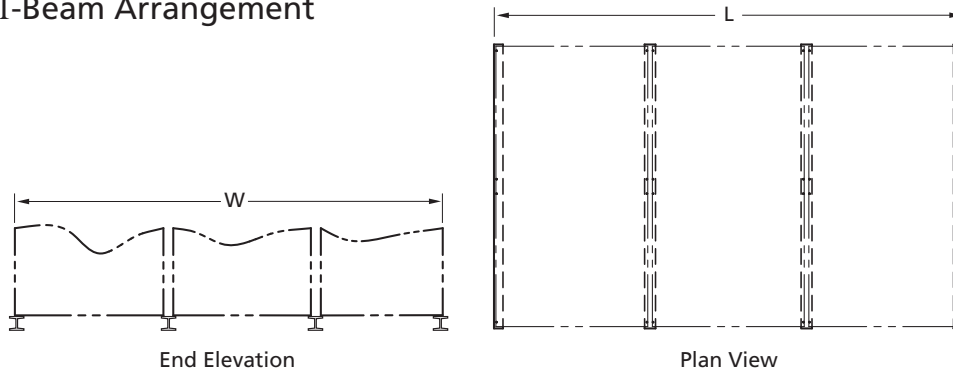

### Models AT/UT/USS 342-526 through 456-926

#### I-Beams Required (By Others)

Dimensions		
Model No.	W	L
342-526 to 342-926	42' 8"	25' 8-7/8"
456-526 to 456-926	57' 3/8"	25' 8-7/8"

#### Notes:

Models Listed Above.

1. These are suggested arrangements for preliminary layout purposes. Consult your EVAPCO representative for factory certified steel support drawings.
2. The recommended support for the AT/UT/USS Cooling Tower is structural I-beams located under the outer flanges and running the entire length of the unit. The unit should be elevated to allow access underneath the unit and to the roof below. Mounting holes, 3/4" in diameter are located in the bottom flanges of the pan to provide for bolting to the structural steel.
3. Beams should be sized in accordance with accepted structural practices. Maximum deflection of beam under unit to be 1/360 of the unit length, not to exceed 1/2".
4. For these models only where four or five support beams are required, deflection may be calculated using 56% of the operating weight on the CENTER BEAMS and 22% on each OUTBOARD beam.
5. Beams should be level before setting the unit in place. Do not level the unit by shimming between it and the I-beams.
6. Support beams and Anchor bolts are to be furnished by others.
7. Dimensions, weights and data are subject to change without notice. Refer to the factory certified drawings for exact dimensions.
8. For alternate layout arrangements please consult the factory. *NOTE: OPTIONAL BOTTOM CONNECTIONS WILL REQUIRE THE UNIT TO BE ELEVATED TO ALLOW FOR PIPING.*







EVAPCO PRODUCTS ARE MANUFACTURED WORLDWIDE.



- World Headquarters/ Research and Development Center
- EVAPCO Facilities

**EVAPCO, Inc. — World Headquarters & Research/Development Center**

**EVAPCO, Inc.** • P.O. Box 1300 • Westminster, MD 21158 USA  
PHONE: 410-756-2600 • FAX: 410-756-6450 • E-MAIL: [marketing@evapco.com](mailto:marketing@evapco.com)

**EVAPCO North America**

**EVAPCO, Inc.**  
**World Headquarters**  
P.O. Box 1300  
Westminster, MD 21158 USA  
Phone: 410-756-2600  
Fax: 410-756-6450  
E-mail: [marketing@evapco.com](mailto:marketing@evapco.com)

**EVAPCO East**  
5151 Allendale Lane  
Taneytown, MD 21787 USA  
Phone: 410-756-2600  
Fax: 410-756-6450  
E-mail: [marketing@evapco.com](mailto:marketing@evapco.com)

**EVAPCO Midwest**  
1723 York Road  
Greenup, IL 62428 USA  
Phone: 217-923-3431  
Fax: 217-923-3300  
E-mail: [evapcomw@evapcomw.com](mailto:evapcomw@evapcomw.com)

**EVAPCO West**  
1900 West Almond Avenue  
Madera, CA 93637 USA  
Phone: 559-673-2207  
Fax: 559-673-2378  
E-mail: [contact@evapcowest.com](mailto:contact@evapcowest.com)

**EVAPCO Iowa**  
925 Quality Drive  
Lake View, IA 51450 USA  
Phone: 712-657-3223  
Fax: 712-657-3226

**EVAPCO Iowa Sales & Engineering**  
215 1st Street, NE  
P.O. Box 88  
Medford, MN 55049 USA  
Phone: 507-446-8005  
Fax: 507-446-8239  
E-mail: [evapcomn@evapcomn.com](mailto:evapcomn@evapcomn.com)

**EVAPCO Newton**  
701 East Jourdan Street  
Newton, IL 62448 USA  
Phone: 618-783-3433  
Fax: 618-783-3499  
E-mail: [evapcomw@evapcomw.com](mailto:evapcomw@evapcomw.com)

**EVAPCO-BLCT Dry Cooling, Inc.**  
981 US Highway 22 West  
Bridgewater, New Jersey 08807 USA  
Phone: 1-908-379-2665  
E-mail: [info@evapco-blct.com](mailto:info@evapco-blct.com)

**Refrigeration Valves & Systems Corporation**  
*A wholly owned subsidiary of EVAPCO, Inc.*  
1520 Crosswind Dr.  
Bryan, TX 77808 USA  
Phone: 979-778-0095  
Fax: 979-778-0030  
E-mail: [rvs@rvscorp.com](mailto:rvs@rvscorp.com)

**McCormack Coil Company, Inc.**  
*A wholly owned subsidiary of EVAPCO, Inc.*  
P.O. Box 1727  
6333 S.W. Lakeview Boulevard  
Lake Oswego, OR 97035 USA  
Phone: 503-639-2137  
Fax: 503-639-1800  
E-mail: [mail@mmccoil.com](mailto:mail@mmccoil.com)

**EvapTech, Inc.**  
*A wholly owned subsidiary of EVAPCO, Inc.*  
8331 Nieman Road  
Lenexa, KS 66214 USA  
Phone: 913-322-5165  
Fax: 913-322-5166  
E-mail: [marketing@evaptech.com](mailto:marketing@evaptech.com)

**Tower Components, Inc.**  
*A wholly owned subsidiary of EVAPCO, Inc.*  
5960 US HWY 64E  
Rameur, NC 27316  
Phone: 336-824-2102  
Fax: 336-824-2190  
E-mail: [mail@towercomponentsinc.com](mailto:mail@towercomponentsinc.com)

**EVAPCO Europe**

**EVAPCO Europe, N.V.**  
**European Headquarters**  
Industrieterrein Oost 4010  
3700 Tongeren, Belgium  
Phone: (32) 12-395029  
Fax: (32) 12-238527  
E-mail: [evapco.europe@evapco.be](mailto:evapco.europe@evapco.be)

**EVAPCO Europe, S.r.l.**  
Via Ciro Menotti 10  
I-20017 Passirana di Rho  
Milan, Italy  
Phone: (39) 02-939-9041  
Fax: (39) 02-935-00840  
E-mail: [evapcoeuropa@evapco.it](mailto:evapcoeuropa@evapco.it)

**EVAPCO Europe, S.r.l.**  
Via Dosso 2  
23020 Piateda Sondrio, Italy

**EVAPCO Europe, GmbH**  
Bovert 22  
D-40670 Meerbusch, Germany  
Phone: (49) 2159-69560  
Fax: (49) 2159-695611  
E-mail: [info@evapco.de](mailto:info@evapco.de)

**Flex coil a/s**  
*A wholly owned subsidiary of EVAPCO, Inc.*  
Knosgårdvej 115  
DK-9440 Aabybro Denmark  
Phone: (45) 9824 4999  
Fax: (45) 9824 4990  
E-mail: [info@flexcoil.dk](mailto:info@flexcoil.dk)

**EVAPCO S.A. (Pty.) Ltd.**  
*A licensed manufacturer of EVAPCO, Inc.*  
18 Quality Road  
Isando 1600  
Republic of South Africa  
Phone: (27) 11-392-6630  
Fax: (27) 11-392-6615  
E-mail: [evapco@evapco.co.za](mailto:evapco@evapco.co.za)

**Evap Egypt Engineering Industries Co.**  
*A licensed manufacturer of EVAPCO, Inc.*  
5 El Nasr Road  
Nasr City, Cairo, Egypt  
Phone: 2 02 24022866/2 02 24044997  
Fax: 2 02 24044667/2 02 24044668  
E-mail: [Primacool@link.net](mailto:Primacool@link.net) / [Shady@primacool.net](mailto:Shady@primacool.net)

**EVAPCO Asia/Pacific**

**EVAPCO Asia/Pacific Headquarters**  
1159 Luoning Rd. Baoshan Industrial Zone  
Shanghai, P. R. China, Postal Code: 200949  
Phone: (86) 21-6687-7786  
Fax: (86) 21-6687-7008  
E-mail: [marketing@evapcochina.com](mailto:marketing@evapcochina.com)

**EVAPCO (Shanghai) Refrigeration Equipment Co., Ltd.**  
1159 Louning Rd., Baoshan Industrial Zone  
Shanghai, P.R. China, Postal Code: 200949  
Phone: (86) 21-6687-7786  
Fax: (86) 21-6687-7008  
E-mail: [marketing@evapcochina.com](mailto:marketing@evapcochina.com)

**Beijing EVAPCO Refrigeration Equipment Co., Ltd.**  
Yan Qi Industrial Development District  
Huai Rou County  
Beijing, P.R. China, Postal Code: 101407  
Phone: (86) 10 6166-7238  
Fax: (86) 10 6166-7395  
E-mail: [evapcobj@evapcochina.com](mailto:evapcobj@evapcochina.com)

**EVAPCO Australia (Pty.) Ltd.**  
34-42 Melbourne Road  
P.O. Box 436  
Riverstone, N.S.W. Australia 2765  
Phone: (61) 2 9627-3322  
Fax: (61) 2 9627-1715  
E-mail: [sales@evapco.com.au](mailto:sales@evapco.com.au)

**EVAPCO Composites Sdn. Bhd.**  
No. 70 (Lot 1289) Jalan Industri 2/3  
Rawang Integrated Industrial Park  
Rawang, Selangor, 48000 Malaysia  
Phone: 60 3 6092-2209  
Fax: 60 3 6092-2210

**EvapTech Asia Pacific Sdn. Bhd.**  
*A wholly owned subsidiary of EvapTech, Inc.*  
IOI Business Park, 2/F Unit 20  
Persiaran Puchong Jaya Selatan  
Bandar Puchong Jaya,  
41710 Puchong, Selangor, Malaysia  
Phone: (60-3) 8070-7255  
Fax: (60-3) 8070-5731  
E-mail: [marketing-ap@evaptech.com](mailto:marketing-ap@evaptech.com)

**EVAPCO...SPECIALISTS IN HEAT TRANSFER PRODUCTS AND SERVICES.**

Visit EVAPCO's Website at: <http://www.evapco.com>



3M/04-12/DGD

Bulletin 331D

©2012 EVAPCO, Inc.

Scan this QR code to learn more about EVAPCO Cooling Towers.

